

# Excelling in Hydrogen

Dutch solutions for a climate-neutral world



# NL

Netherlands

# Building a hydrogen ecosystem

A schematically depicted hydrogen value chain showing the steps from production (upstream) to infrastructure, transport and storage (midstream) to various end uses (downstream).

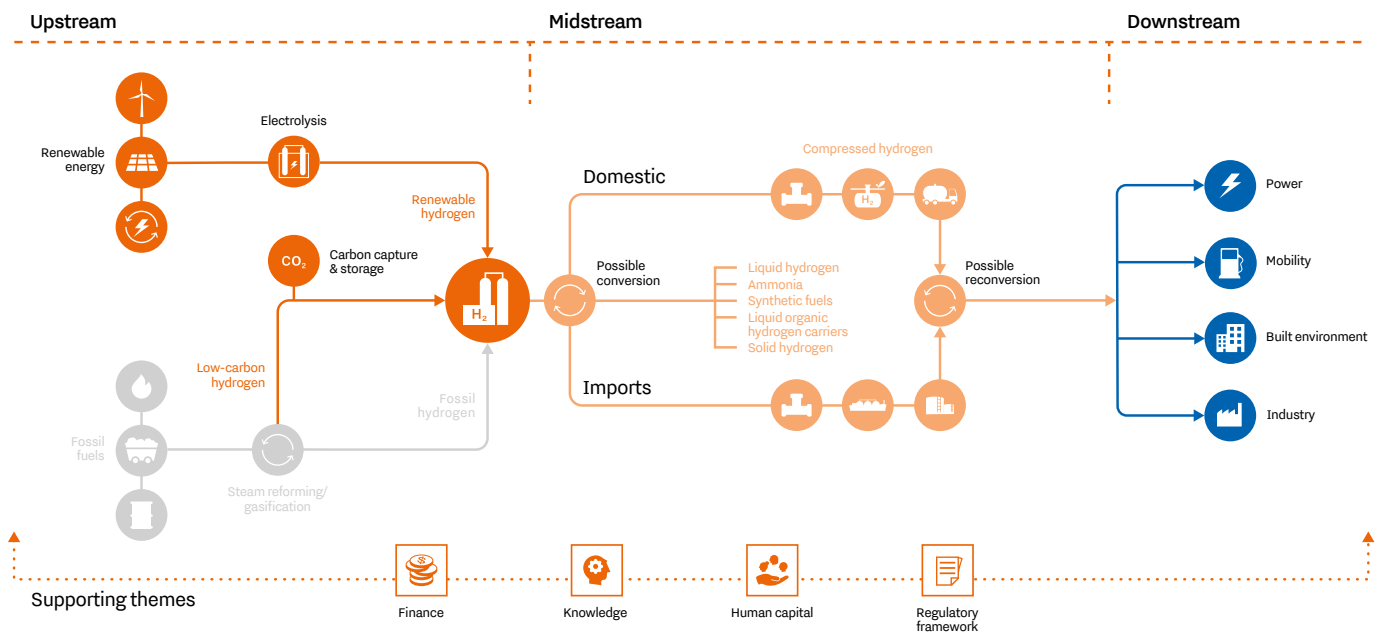

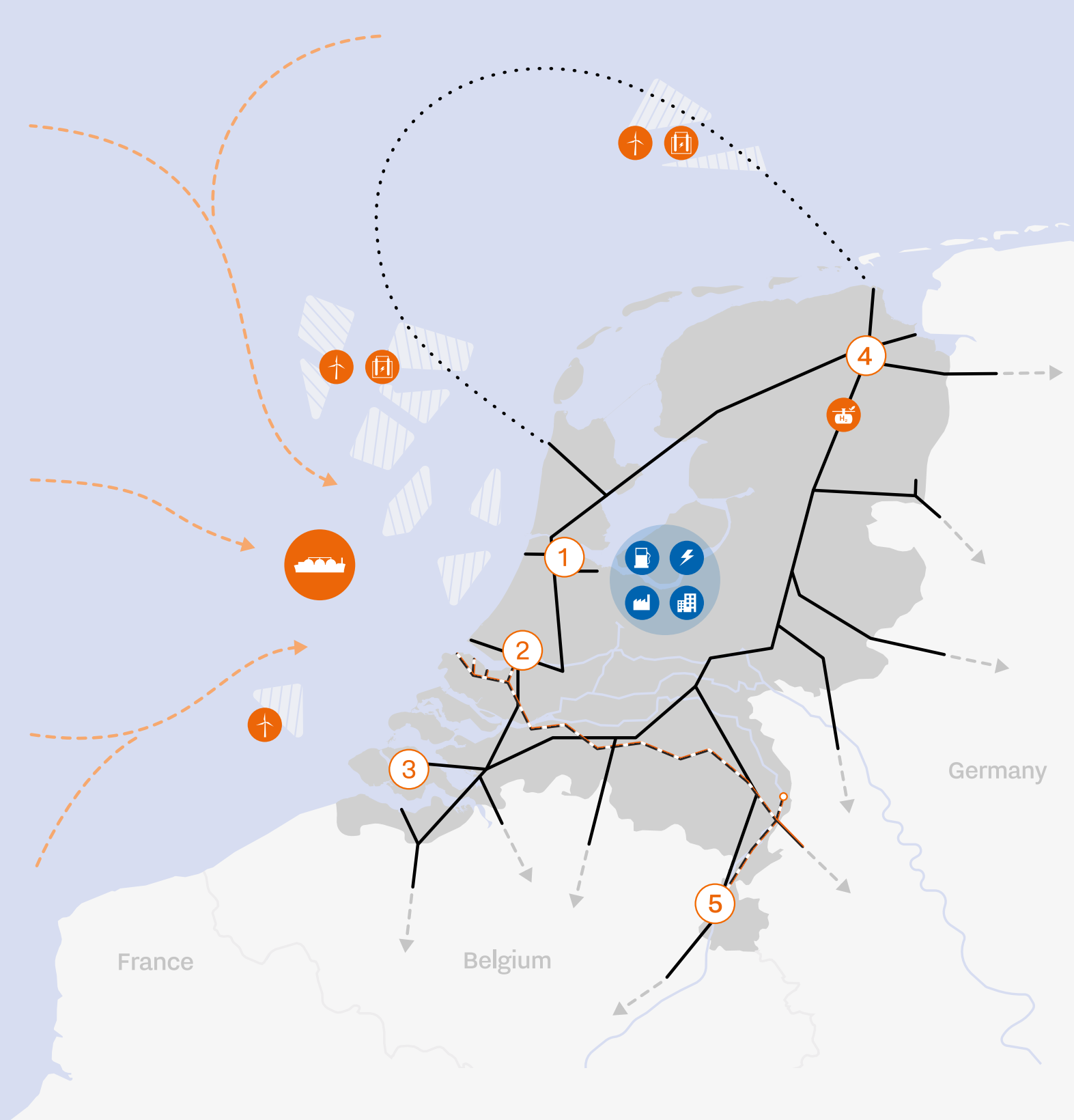

**Major industrial clusters**

- ① Amsterdam
- ② Rotterdam
- ③ Zeeland
- ④ Groningen
- ⑤ Chemelot

Upstream	Electrolysis	Offshore wind energy
Midstream	(Re)conversion	Import
Downstream	Industry	Power
Onshore hydrogen network	Offshore hydrogen network	Delta Rhine Corridor
	Storage	Mobility
	Underground storage	Built environment



# The second gas revolution

Over 60 years ago, large natural gas reserves were discovered in the Netherlands. As a result, one of the world's most extensive and sophisticated gas grids was developed. A second gas revolution is well underway with the introduction of renewable and low-carbon hydrogen.

Next to its use as feedstock or fuel, hydrogen can, as an energy carrier, solve systemic issues by enabling further integration of renewable energy in our energy system. Although challenges lie ahead, fostering the development of hydrogen is key to making the energy transition a success.





On Friday 27 October, his Majesty the King of the Netherlands performed the official ceremony to start work on the construction of a national hydrogen network in the Netherlands. From 2030, the national hydrogen network will connect the Netherlands' major industrial areas to each other and to Germany and Belgium. The Dutch government commissioned Gasunie in 2022 to develop the hydrogen network.

# Index

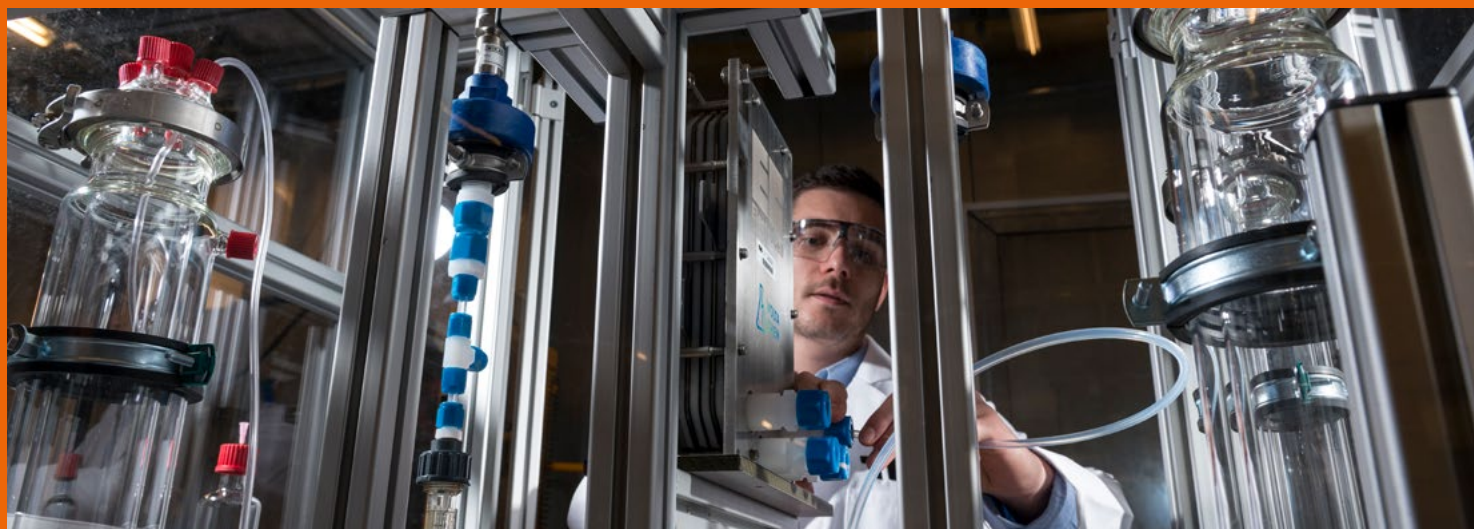

The second gas revolution	4
Creating international partnerships essential to stimulate the global hydrogen economy	7
Hydrogen A critical enabler in the global energy transition	8
Hydrogen production Making clean hydrogen competitive	12
Transport, storage and distribution Towards an integrated hydrogen infrastructure	16
Hydrogen applications Creating demand	22
Dutch hydrogen flagship projects	24
Mission H2: The Hydrogen Map	25
Partners for International Business (PIB): Creating solutions for a hydrogen-powered economy together	26
Five benefits of doing business with the Netherlands	28
Dutch hydrogen expertise	30
Company profiles	32



# Creating international partnerships is essential to stimulate the global hydrogen economy

Nations worldwide are in transition towards a renewable-powered energy system to fight the threat of global warming. The latest IPCC report stresses the urgency to increase the speed and scale of renewable deployment to reach the goals of the Paris Agreement.

Hydrogen can, and - in my opinion - will play a key role in achieving the transition towards a climate-neutral and circular economy. Hydrogen has a multitude of potential applications across energy-intensive sectors. It can be used as feedstock and it can replace fossil fuels in high temperature processes in our industry. Due to its high energy density, it is suitable for heavy-duty long distance transportation purposes, and it can partially play a role as sustainable backup energy source for longer term, seasonal storages.

However, truly incorporating hydrogen into the global energy system remains challenging. The large-scale (sustainable) hydrogen production, development of a new European and international infrastructure, and a global hydrogen market are still in the early stages of development. This market is expected to be of a similar form and magnitude as the current oil and gas markets. Especially because the climate challenges are global and hydrogen is only one of few alternatives available.

To achieve a truly integrated hydrogen system, it requires a cooperating international community. The Netherlands' enormous experience with natural gas, as the "gas roundabout" of North-West Europe, makes it the ideal and well willing candidate for a substantial and constructive role within a hydrogen-based economy. Our ports and the fact that we are well-connected to other Northwest European countries provide a geographically strategic position that we can use to become the center of a European and perhaps a global hydrogen market. Furthermore, Dutch knowledge institutions and regional ecosystems, such as the green hydrogen valleys, are extremely effective in translating ideas into practice within and outside of the Netherlands. As this brochure illustrates, the Netherlands is also home to a wide variety of ambitious companies, ready to kick-start the European and global hydrogen market. In that perspective I'm proud of the Dutch ambition to lead the development of hydrogen markets.

Activities in the Netherlands related to technological innovation and business developments are increasing. Creating international partnerships is essential to stimulate the development of a global hydrogen economy. It is our joint responsibility to turn initiatives into concrete projects and operational systems and thereby demonstrating hydrogen's full potential in a sustainable energy system.

We understand that realizing hydrogen's full potential will take time in which considerable challenges must continuously be overcome. Our aim is to support you in achieving your projects, ambitions and goals.

**Jörg Gigler**  
TKI New Gas  
(Energy Innovation NL)

**David Koole & Kenneth Colijn**  
Netherlands Enterprise Agency  
(RVO)

**Jelle Blekxtoon**  
FME the Dutch employers'  
association in the  
technology sector





Hydrogen

# A critical enabler in the global energy transition

The race is on to substantially reduce our global carbon footprint in time to halt the devastating consequences of climate change.

International cooperation and technological innovations are key enablers of successful, large-scale decarbonisation of our societies. Clean hydrogen provides a solution to overcome some of the most persistent challenges in this transition.







Scaling up clean hydrogen production requires large amounts of renewable electricity. Wind power in particular is a vital enabler. The Netherlands aims to install 21 GW of offshore wind capacity by 2030, and to produce at least another 35 Terawatt hour of renewable energy on land. Given the high expectations for clean hydrogen usage for multiple applications, even more capacity is needed to fulfil these ambitions.

Scaling up clean hydrogen production requires large amounts of renewable electricity. Wind power in particular is a vital enabler. The Netherlands aims to install 21 GW of offshore wind capacity by 2030, and to produce at least another 35 Terawatt hour of renewable energy on land. In addition, floating solar parks in between the wind turbines of offshore wind farms could increase the total production of offshore renewable energy. Solar energy being complementary to wind energy, helps with intermittency challenges and enables a more efficient use of the electricity grid. Given the high expectations for clean hydrogen usage for multiple applications, even more capacity is needed to fulfil these ambitions.

As a signatory of the Paris Climate Agreement, the Dutch government has enshrined in law its commitment to a decarbonised future, and has agreed ambitious targets (see the box) in a national Climate Agreement. In addition, the Netherlands is committed to working proactively on the Sustainable Development Goals (SDGs). As such, the Dutch government is committed to reducing carbon emissions while making sure potential negative effects of this transition on the wellbeing of people and communities anywhere in the world are limited. For one of the most densely populated and industrialised countries in the world, meeting these targets will present considerable challenges. Billions of euros will be invested over the coming decade alone to accelerate the energy transition. The Netherlands plans sizeable investments in renewable energy, especially offshore wind energy and solar energy. Other key policies are aimed at putting all this carbon-neutral power to good use, through large-scale electrification of cars, residential heating through heat pumps and the electrification of industrial processes, while at the same time providing sustainable feedstocks to the industry.

Yet, even with these ambitious policies, persistent challenges remain. For example, the country's large industrial sector requires huge amounts of high temperature process heat, as well as feasible alternatives for fossil-based feedstock. As we become increasingly reliant on intermittent energy sources, such as wind and solar power, we urgently need solutions for storing large amounts of energy to avoid grid congestion and assure security of supply, both in the short term and across seasons. Yet another challenge is to decarbonise the marine shipping and heavy duty transport sectors as well as finding a substitute for the natural gas used for heating buildings.

#### Hydrogen: a crucial link

Hydrogen is widely seen as a crucial technology to overcome such fundamental obstacles to full decarbonisation. It can be used as an alternative to natural gas in industrial processes, as a feedstock for the production of chemicals, and as a carbon-neutral fuel in virtually all modes of heavy duty transport, especially those for which electrification is not (yet) an option. Through electrolysis, hydrogen can be used to store and distribute large amounts of renewable electricity, paving the way for further large-scale investment in wind and solar power and creating new opportunities for grid balancing, seasonal storage, providing large-scale energy infrastructure alternatives and even global exports of renewable energy. The hydrogen value chain, both schematically depicted and geographically visualised for the Netherlands, can be found on page 26.

#### The Dutch angle

The Dutch approach to building a hydrogen-based future has several distinctive characteristics. First of all, it is explicitly driven by the climate policies and commitments previously described. Secondly, its scope takes in the

## Facts and figures on the Dutch hydrogen ecosystem



### 180 Petajoules

The Netherlands has a large potential of reducing carbon emissions by transitioning from being Europe's second largest hydrogen producer, with an annual production and usage of 180 PJ of (fossil-based) hydrogen, to becoming a hub for clean hydrogen.



### 3-4 GW / 2030

To enable large-scale production of renewable hydrogen, the Dutch ambition is to have installed at least 3-4 GW of electrolyser capacity by 2030 ( $\pm 10\%$  of the total EU target for that year) and 8 GW in 2032. The northern region of the Netherlands alone is aiming for an annual production of 65 PJ of clean hydrogen by 2030.



### 21 GW / 2030

Offshore wind is a crucial enabler of scaling up the production of carbon-neutral hydrogen. Planned projects in the Dutch zone of the North Sea add up to 21 GW of offshore wind capacity by 2030, while there is enough space for a further scale-up to 40 GW in 2040 and 75 GW in 2050.



### 136,000 km

The Netherlands, together with Belgium and France, already has over 1,000 km of dedicated hydrogen pipeline. The country's dense natural gas grid (136,000 km of high quality pipeline) can -partially- be retrofitted to transport hydrogen at an acceptable cost. This will accelerate the development of an open access and regulated 'national hydrogen backbone', which should be ready in 2030.



The Netherlands is strategically located at the heart of the European hydrogen infrastructure proposed by 11 European grid operators. Addressable regional demand in North-western Europe alone is estimated at 400 PJ by 2030.



entire value chain. Rather than viewing hydrogen production and various applications as separate issues, the Netherlands has adopted an integrated system approach to developing a ‘hydrogen market’. Dozens of pilot projects are underway in which companies, regional and local governments, hydrogen associations and platforms, and Research and Technology Organisations (RTOs) are building a complete hydrogen ecosystem. They not only focus on technology but also on creating demand, business models and on tackling regulatory, human capital, certification and standardisation and safety issues. This is often done in public-private partnerships and in a very pragmatic way: we have an open approach to innovation which encourages experimentation. Thirdly, our outlook on hydrogen is decidedly global in nature. Living in a small country with a strategic location, we have always been strongly aware of the need to look beyond the country’s borders. It has caused Dutch companies, ports, research institutes and government to be well-connected to foreign markets with strong collaborative networks all over the world. Therefore, in addition to developing a Dutch hydrogen ecosystem and value chain, the Netherlands strives to help accelerate the global, large-scale adoption of hydrogen as a carbon-neutral energy carrier. And building on the strategic location in global fuel and feedstock logistics, the Netherlands is aiming to become a European hub for the production and transport of low-carbon fuels and especially low-carbon and renewable hydrogen.

### Strong foundations

These ambitions are underpinned by strong foundations. Currently, the Netherlands is already Europe’s second largest producer of fossil-based hydrogen and is determined to decarbonise this sector. Since large-scale production of renewable (green) hydrogen will take time, ‘blue’ or low-carbon hydrogen is an important intermediate step. In this case, hydrogen is produced from natural gas but the CO<sub>2</sub> released in the process is captured and stored resulting in drastically reduced carbon emissions released into the air. The Netherlands also has one of the world’s most sophisticated natural gas infrastructures, achieved by developing a national gas grid reaching into nearly every home and business. And in doing so, the Dutch gas sector has built up extensive expertise in handling, monitoring and storing gas. In addition, the country is a major European hub for cross-border trade in natural gas, both in gaseous and liquefied forms. These are strong foundations as we seek to expand and repurpose our existing infrastructure, transforming it into a flexible grid that enables large-

### Facilitating international collaboration

Building collaborations with Dutch hydrogen businesses could increase your company’s financing possibilities. International B2B cooperation and cross-border consortia are stimulated and facilitated by the Netherlands Enterprise Agency, the Ministry of Foreign Affairs, Innovation NL, FME, NWBA (Hydrogen & fuel cell association), NL Hydrogen and other supporting organisations in the Netherlands. Reach out to learn more (p.150). Additionally, an overview of different Dutch and European hydrogen subsidies can be found on the website of the Dutch National Hydrogen Programme (in Dutch): [www.nationaalwaterstofprogramma.nl](http://www.nationaalwaterstofprogramma.nl)

scale rollout of hydrogen.

Still, the required technology for renewable hydrogen is being developed at a rapid pace (see next chapter) with many associated factors in place. There is a highly developed manufacturing industry, with hundreds of companies at every step of the value chain, from producing crucial components for electrolyzers to manufacturers of special vehicles and buses. This position is underlined by the launch of an Electrolyser Manufacturing Platform (EMP-NL) with more than 21 Dutch technology companies and knowledge partners assembled to accelerate innovations in the hydrogen economy.

### The European perspective

Building a hydrogen economy is a major undertaking, that no single country can achieve by itself. We strive for working in close international cooperation in research & development, European policies, demonstration projects and implementation of new technologies that the world as a whole could benefit from. Dutch initiatives are therefore closely aligned with European partners and EU-wide innovation programmes. Examples include:

- Clean Hydrogen Partnership. Succeeding the Fuel Cells & Hydrogen Joint Undertaking (FCH JU), this partnership aims to implement the EU Green Deal and the EU hydrogen strategy by accelerating the production, distribution and storage of clean hydrogen in the EU, especially within hard-to-abate sectors.
- Large projects could acquire the status of Important Project of Common European Interest (IPCEI). IPCEIs focus on large scale research, demonstration and implementation projects of European interest in which more public financing is possible compared to what is allowed under regular state aid regulations. In 2022, the Dutch government selected seven large-scale renewable hydrogen production projects across the country that combined will receive a subsidy of €800-million-euro. With a combined capacity of potentially 1,150 MW it already covers at least a quarter of the 2030 goals in the Netherlands.



The north of the Netherlands was the first region to receive European funding as a ‘Hydrogen Valley’. Its potential is widely recognised: the initiative was backed by dozens of companies from six different countries. In 2020 regional authorities, companies and knowledge partners published an ambitious investment plan of nine billion euros over the next ten years. It encompasses over 50 projects covering the entire hydrogen value chain, including large-scale production, the development of distribution and storage infrastructure and a range of applications. Currently there are six recognized hydrogen valleys in the Netherlands.



Hydrogen production

# Making clean hydrogen competitive

Hydrogen is only as clean as the energy used to produce it. For hydrogen to have a meaningful impact on the global energy transition, the production of clean hydrogen has to be scaled up substantially. And this, in turn, requires innovations that make its dominant production process – electrolysis – more robust and cost-competitive.





TNO's Faraday lab in Petten is an innovation lab that focuses on optimising existing electrolysis technologies such as PEM, alkaline, SOEC and AEM. It enables manufacturers of electrolysers and their suppliers to develop and test new materials, components and applications under different conditions.



Agreement exists in and outside the Netherlands about the necessity of increasing the availability of clean hydrogen. Yet it has struggled to make a breakthrough: the cost is still several times that of fossil-based hydrogen, and limited demand has, so far, hampered efforts to scale up electrolysis installations and reduce the cost. Current market conditions are challenging, causing offtakers to be reluctant to commit to large scale projects.

#### Next-generation electrolyzers

Many Dutch initiatives focus on the key challenge of making clean hydrogen more affordable. An example is TNO's Faraday laboratory in Petten, one of Europe's largest hydrogen research facilities. In this open innovation lab, researchers and a wide range of industry partners are working to optimise existing electrolysis technologies such as PEM, alkaline, SOEC and AEM. The innovations developed here focus on improving efficiency, boosting production capacity and finding robust, cheaper alternatives to the rare materials used in current electrolyzers. Other examples of cross-fertilisation between research institutes and industry partners include VoltaChem, aimed at the electrification of industry, and the Hydrohub innovation programme of ISPT (Institute of Sustainable Process Technology), including its MW-test centre for electrolyzers, situated in the Energy Transition Centre (EnTranCe) in the city of Groningen. In addition, GroenvermogenNL is an integrated large scale innovation program for green capacity for the Dutch economy and society. The program makes a substantial contribution to upscaling climate-neutral hydrogen and the use of green electrons in energy-intensive industries. In addition to working towards the goals of the energy and raw materials transition, GroenvermogenNL will also strengthen the business sector in the Netherlands.

### *Innovative pilot projects help us understand and solve challenges around system integration and net congestion.*

In addition to state-of-the-art facilities and research groups, the Dutch hydrogen ecosystem includes a wide range of technology providers. Already many companies are working on hydrogen production technologies. These include manufacturers of electrolyser components such as membranes, as well as stack integrators, suppliers of supporting technology and system integrators with the expertise and scale to build complete electrolyser installations. Many of these companies have extensive and valuable experience in other industrial markets, which can help to make the production process of electrolyzers more robust and efficient. For example, by standardising and automating production processes, or by developing efficient water purification technologies.

#### Scaling up production capacity

Upscaling electrolysis capacity in the Netherlands has been a focal point of Dutch hydrogen policies, resulting in regulatory policies and financial instruments to stimulate this development.

Current electrolysis installations typically have a capacity of a few megawatts, but to facilitate the huge growth of renewable energy (as well as to compete with much larger 'grey' and 'blue' hydrogen plants and fossil alternatives), this capacity will have to increase towards gigawatt-scale. This requires the development of hydrogen plants incorporating numerous electrolyser stacks. In ISPT's Hydrohub programme, a large consortium of research and industry partners has taken up the challenge and has finished the conceptual design for a 'Gigawatt Electrolyser' to be installed in the Netherlands before 2030.

Furthermore, to optimise electrolyser technology, Dutch hydrogen companies are tackling the question of what is needed for larger scale use, but also the integration into the electrical grid and solving infrastructural and practical challenges. Key insights on scaling are obtained from offshore, inland and (underground) storage projects. One example is demonstrated by a operational pilot project in Oosterwolde, near Assen called 'Sinnewetterstof'. Through Alliander, this project uses a 1.4 MW Alkaline electrolyser that is currently producing hydrogen for dedicated use through tube trailers, being power directly through a solar farm. This project emphasises on understanding and solving the challenges around system integration, scaling infrastructure compatibility and net congestion (see also Flagship Project p. 24).

#### Moving offshore

Finally, an increasing number of researchers and companies are focusing not so much on the question of how electrolysis can be implemented, but where. This question arises from the fact that hydrogen is widely seen as an ideal storage and transport medium for electricity. This has encouraged efforts to install electrolyzers closer to wind or solar installations, in order to minimise the cost (and inevitable energy losses) of transmission infrastructure. In 2023, the Dutch government announced the plans to have 500-MW offshore electrolysis capacity connected to the offshore wind park operational around 2031.

Recent innovations in this area include one of the world's first offshore electrolysis platform in the North Sea, called PosHYdon. This is an existing oil and gas platform off the Dutch coast being converted to the world's very first offshore hydrogen platform. Electricity generated by offshore wind turbines will be used to convert seawater into demineralised water and to power a 1-MW electrolyser producing clean hydrogen which is transported through natural gas pipelines to offtakers.

Offshore electrolysis presents an interesting perspective for the longer term. It raises the possibility of converting disused oil and gas platforms into offshore electrolysis installations. Although sea water currently has to be desalinated before it can be used for electrolysis, Dutch researchers are looking at ways to use sea water directly, which would potentially open up new opportunities for electrolysis in areas where freshwater is scarce. And perhaps even for large-scale electrolysis further offshore. The Netherlands is also exploring the possibilities of creating artificial energy islands in the North Sea, to be used as hydrogen production hubs for the many offshore wind farms to be built over the coming years.



The offshore wind area "Ten noorden van de Waddeneilanden", located 56 km off the coast of the north of the Netherlands, has been designated for large-scale offshore hydrogen production. The preferred location could provide up to 500 MW of electrolysis capacity to be operational in 2031. The sheer size would make it world's largest offshore hydrogen production location. (Photo: Gemini Windpark)



The Hydrohub Gigawatt Electrolysis Factory project, a consortium of companies, universities and knowledge institutes, is paving the way for the design of an electrolysis plant on an industrially relevant scale of 1 GW by 2030. It is part of the Institute for Sustainable Process Technology's Hydrohub programme, which also includes a state-of-the-art open test centre based at the ENTRANCE facility, part of the Hanze University of Applied Sciences in Groningen.



HYGRO specialises in the production, delivery and distribution of hydrogen produced directly from wind. It is building a 4-MW wind turbine with an integrated electrolyser in the province of North Holland. The aim is to maximise synergy between wind power, hydrogen and pipeline & storage technology. The concept optimises conversion of wind power to hydrogen, which can be transported at much lower cost than electricity and with a significantly lower impact on spatial planning.



An existing oil and gas platform off the Dutch coast is being converted to the world's first offshore hydrogen platform. Electricity generated by offshore wind turbines will be used to convert seawater into demineralised water and to power a 1-MW electrolyser producing clean hydrogen.



In the northern coastal town of Delfzijl, gas grid operator Gasunie and HyCC are planning to build a 20-MW electrolyser, which will produce 3,000 tonnes of clean hydrogen each year. They are also studying options to expand its capacity to 60 MW in order to produce sustainable jet fuel. (Photo: Groningen Seaports/Koos Boertjens)



Transport, storage and distribution

# Towards an integrated hydrogen infrastructure

Large-scale production of clean hydrogen is one crucial step towards a carbon-neutral future. Equally important is the challenge of distributing vast amounts of hydrogen safely and cost-effectively. Dutch innovations are contributing to the development of a hydrogen economy – both at home and abroad.





At the Tweede Maasvlakte in the Port of Rotterdam, a conversion park is being constructed with large-scale electrolyzers to convert wind energy into renewable hydrogen. Subsequently, the hydrogen will be distributed to industries throughout the Port area via the hydrogen backbone. Together, the projects will save millions of tons of CO<sub>2</sub> in one of Europe's largest port areas.

The most straightforward way of transporting hydrogen is through pipelines, and the Netherlands is well equipped to build a nationwide hydrogen network. That is because the foundation is already present. First of all, a dedicated hydrogen pipeline network of more than 1,000 km is in place, connected to industrial sites also in Belgium and France.

The existing dense gas infrastructure can, after modest alterations, be repurposed for hydrogen transport. In some cases, new pipelines must be built to integrate all relevant industrial clusters, with connections to the rest of Northwest Europe including Germany, Belgium, Denmark and others. This national pipeline infrastructure for hydrogen transport is being developed by Gasunie due to be finalized around 2030. This 'hydrogen backbone' will connect all five industrial clusters with the Dutch ports and neighbouring countries. A final investment decision for the construction of the backbone has been made in June 2023 and construction of a new pipeline in the Port of Rotterdam has started in October 2023. Not just by mixing hydrogen into the natural gas flow, but by replacing one with the other. In the province of Zeeland, in the southwest, a 12 km-long industrial gas pipeline transports around 400,000 tonnes of hydrogen per year, and nearly a dozen pilot projects are underway in residential areas to replace natural gas with hydrogen, using the existing gas infrastructure. Over the coming years, this trend is set to gather pace. One of the key policies on the Dutch climate agenda is that over 2 million homes must have switched to natural gas alternatives by 2030. This will help to decarbonise the built environment sector whilst providing households with a long-term solution for the energy supply of their homes. Hydrogen has the potential to be an interesting solution besides district heating networks and the installation of electric heat pumps. And as the demand for natural gas falls, much of the network's capacity becomes available for hydrogen transport, especially since the grid includes many 'parallel' pipelines. The national research consortium HyDelta investigates several issues associated with the use of existing natural gas assets for hydrogen.

In addition to transporting hydrogen, the existing natural gas system also offers opportunities for storage, in order to help bridge seasonal variations in the availability of renewable power, or to balance the power grid. For example, in the north of the country, natural gas is stored in huge salt caverns, with a capacity of hundreds of millions of cubic metres. Pilot projects have demonstrated that hydrogen can be safely stored here as well. In addition to this, researchers and industry specialists are already examining the technical and economic feasibility of storing hydrogen in empty gas fields, both on land and in the North Sea. HyStock is one of the hydrogen storage projects in empty salt caverns, ready for storage in 2028. Building a hydrogen economy requires other and more flexible modes of transport besides pipelines and, in this respect as well, the Dutch are working on a range of innovations. For example, researchers at TNO and industry partners are developing special hydrogen tanks. This includes the development of new materials that enable hydrogen to be stored at very high pressure or extremely low temperatures, paving the way for safe and cost-effective transport by road, rail or

ship. Other Dutch companies focus on binding hydrogen with other materials, such as nitrogen, carbon dioxide or toluene (a so-called Liquid Organic Hydrogen Carrier: LOHC), to create a carrier liquid that is much easier to transport, sometimes even in existing oil tankers.

*Over the next few decades, Europe is expected to become a net importer of clean hydrogen, and we are ready to contribute to the change.*

The growing market of clean hydrogen requires a properly functioning exchange platform and efficient pricing. This is being explored in the HyXchange project. It conducted a study in 2021 defining the necessary elements of such an international exchange followed by a successful pilot in 2022. HyXchange will continue to test their findings in pilot projects and simulations which will facilitate further growth and development of the global hydrogen market.

Our focus lies on establishing a comprehensive hydrogen infrastructure within the Netherlands, while also actively seeking avenues for international cooperation to extend this infrastructure globally. Collaborating proactively with partners is essential to collectively meet our climate objectives. This commitment is evident in the Hy3 and Hy3+ initiatives, which delve into the transnational hydrogen economy spanning the Netherlands, Germany, and Belgium. These projects aim to uncover opportunities, foster cross-border infrastructure endeavors, and address potential obstacles. Through Hy3 and Hy3+, we're driving forward seamless collaboration and the advancement of an integrated hydrogen network.

#### **A hydrogen hub**

While such innovations open up new opportunities for distributing hydrogen in the last few steps of the value chain, they can also be applied to large-scale transport over (very) long distances. There is an urgent need for such solutions, since there is a huge potential for a global hydrogen market. The low cost of electricity in areas with abundant sunshine and/or favourable wind conditions boosts the business case for large-scale renewable hydrogen production. Over the next few decades, Northwest Europe is expected to become a net importer of clean hydrogen, and we are ready to contribute to the change.

Some of Europe's busiest transport corridors converge on the Netherlands, thanks to excellent road, rail and inland shipping infrastructure, as well as pipeline connections with much of Europe. The Port of Rotterdam is the largest port for oil and (liquefied) natural gas in Europe, and is working with industrial partners to build up a similar position for hydrogen. Several multinationals are planning to build electrolyzers in Rotterdam, and work has started on a dedicated hydrogen pipeline infrastructure. Other companies are focusing on the technology needed for large hydrogen tankers, and for storage infrastructure not just in the Netherlands, but also in the countries that are looking to capitalise on their potential as hydrogen exporters.





As of April 2024, the Dutch government has signed bilateral Memoranda of Understanding (MoU) or other cooperation agreements on hydrogen with Australia, Canada, Chile, Denmark, Germany, Indonesia, Japan, Morocco, Namibia, Norway, Oman, Portugal, Saudi Arabia, South Africa, Spain, the United Arab Emirates, the United States and Uruguay. Such partnerships are highly valued by public and private organisations as it paves the way for further international cooperation. It shows the value that the Netherlands gives to building hydrogen corridors in North-Western Europe as well as preparing for large-scale import of clean hydrogen.



The village of Stad aan 't Haringvliet is home to an active community of residents who are making a collective effort to phase out natural gas. Grid operator Stedin has already confirmed that existing gas infrastructure can be used to transport hydrogen to the village's 600 homes. Elsewhere, in Hoogeveen in the north of the country, similar plans have been developed which will allow hydrogen to be transported to over 500 new and existing houses over the next five years.

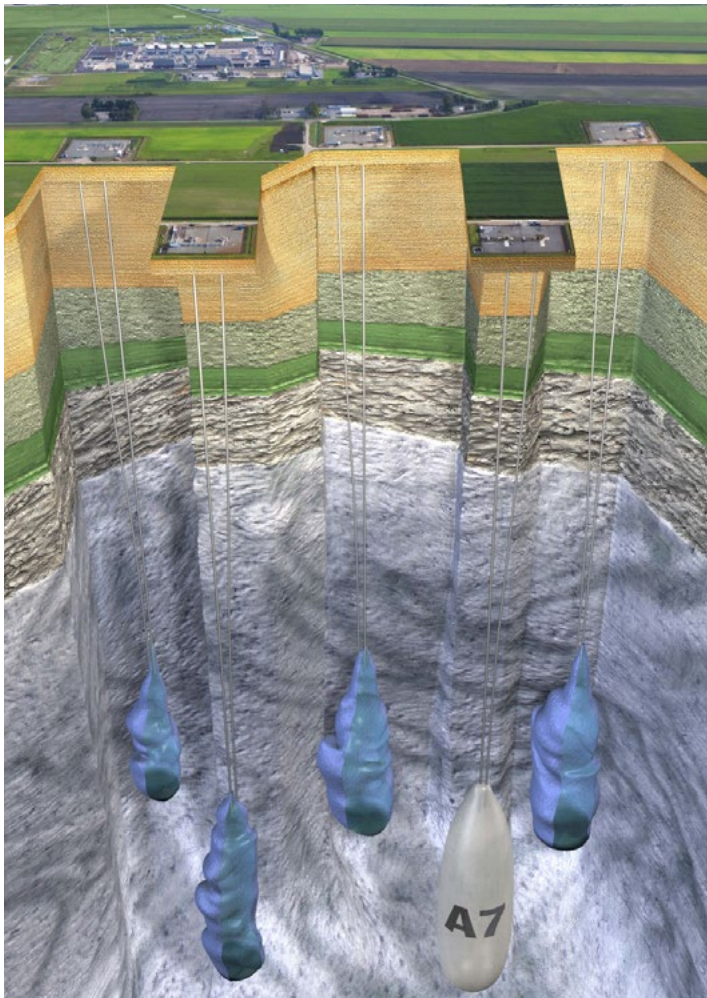

Dutch gas grid operator Gasunie is developing its first large-scale hydrogen storage site at HyStock, Zuidwending. Here its subsidiary Energystock operates a storage facility with six underground salt caverns, which are currently used for storing natural gas. Four new caverns will be developed for hydrogen, with a total storage capacity of more than 20,000 tonnes.



In 2023 the Netherlands joined the H2Global initiative. The German initiative aims to facilitate the import of renewable hydrogen derivatives. In 2024 a Dutch/German tender will be published with a budget of 600 Million Euros. The agreement was signed during the visit of His Majesty the King to Germany in November 2023.



In the province of Zeeland in the South an existing, 12 kilometre natural gas pipeline has been adapted to transport (residual) hydrogen from Dow Chemical's production site in Terneuzen to Yara's fertilizer plant in nearby Sluiskil. The initiative has allowed the two chemical companies to achieve CO2 savings of 10,000 tonnes per year.



A photograph of a male worker in a blue and grey high-visibility uniform working on a blue industrial machine in a factory. The background shows a large industrial space with red overhead beams and various pieces of equipment.

Hydrogen applications

# Creating demand

Kickstarting the hydrogen economy requires investments in supply and infrastructure, but naturally also a large and stable demand. Researchers and companies are working on a wide range of potential hydrogen applications, focusing on those with the highest impact on reducing carbon emissions.





Holthausen Clean Technology is a fast-growing family business which specialises in converting a wide range of lorries and special vehicles to run on hydrogen.



### Industrial applications

One of the areas in which hydrogen is expected to have a large impact on reducing overall CO<sub>2</sub> emissions is in industrial processes which require high-temperature heat. These are typically large installations which consume huge amounts of fossil fuel, mainly natural gas. The goal is to adapt industrial burner systems and ensure they can deal with hydrogen's radically different combustion characteristics. In combination with CO or CO<sub>2</sub>, hydrogen also has a vast potential to replace petroleum and natural gas as a basis for the production of synthetic fuels and sustainable bulk chemicals, such as methanol, alkenes and aromatics.

### Mobility

Many Dutch innovations focus on modes of transport for which electrification is not the most preferred option, such as ships and heavy duty transport. For example, in our large inland shipping sector, the goal is to introduce 150 hydrogen-powered barges over the next 10 years. And, as part of a pan-European project initiated by the province of South Holland, hydrogen fuelling stations will be built along the shipping corridor between Rotterdam and Genoa, Italy via Germany. Dutch solutions for road transport include hydrogen-fuelled buses and trucks, range extenders for electric vehicles and the technology needed for hydrogen refuelling stations.

### Residential heating

Gas-fired heating has been the standard for nearly every Dutch home for decades, yet this is about to change. Newly built homes are no longer connected to the gas grid and, over the next ten years, millions of existing homes are expected to switch to sustainable alternatives such as district heating and heat pumps. While for many newer homes this can be accomplished using solar energy combined with heat pumps or geothermal heating, for many older homes, hydrogen may be a more feasible solution. The existing gas infrastructure could be adapted to distribute hydrogen (see also p. 16 and further). The Netherlands has a strong ecosystem of condensing boiler manufacturers, who are investing heavily in transitioning from natural gas to hydrogen. Several have marketed models suitable for gas mixtures with up to 30% hydrogen, and have showcased 100%-hydrogen boilers. Others are working on technology that would allow existing gas-fuelled condensing boilers to be retrofitted for use with hydrogen.

### Flexible power infrastructure

Since our electricity supply is becoming more and more dependent on renewable – and intermittent – energy sources, it is important to ensure adequate buffers of carbon-neutral power. Currently, gas and coal-fired power plants provide the necessary back-up to offset a sudden drop in wind or solar power. We are working on the technology to convert these power plants to run on (carbon-neutral) hydrogen, as well as on the storage solutions needed to create large hydrogen buffers (see p. 16). Other innovations include flexible electrolysers that can be used for grid balancing, frequency containment or - combined with fuel cells for example - as emergency power systems.



In the Eemshaven, the port in the north of the Netherlands an existing gas-fired power plant is being prepared to convert to hydrogen. After acquiring the plant from Vattenfall in 2022, RWE continues to pursue the ambition of having the first of the plant's three 440-MW units run on (low-carbon) hydrogen. By converting the remaining units and switching to clean hydrogen by 2030, this is likely to become the world's first carbon-neutral hydrogen-fuelled power plant.

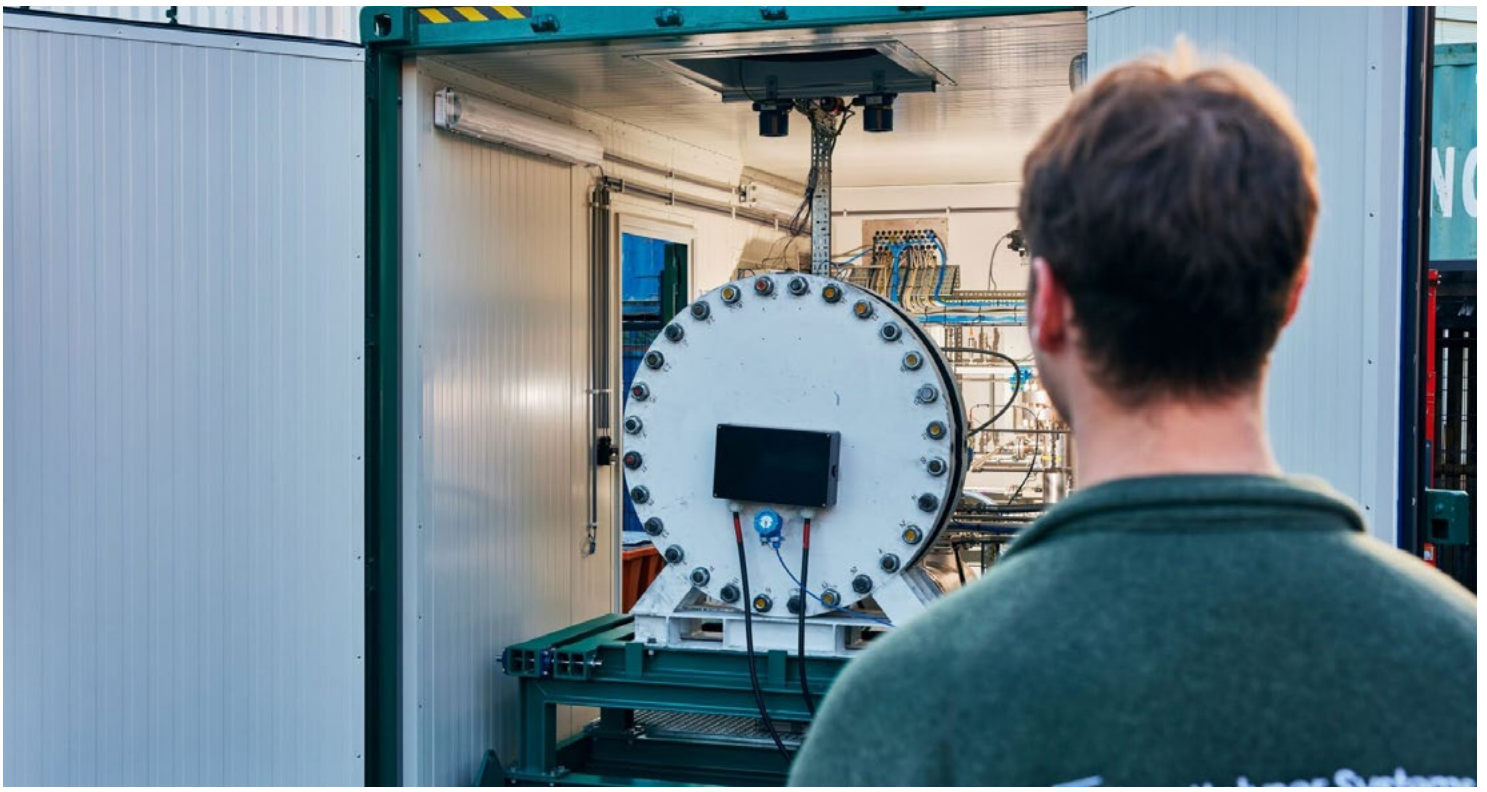

Entrepreneurs at Battolyser Systems have developed the world's first integrated battery electrolyser system. To help commercialise their technology, a financing agreement of 40 million euros has been reached with the European Investment Bank. Their innovative technology operates as both a battery and an electrolyser, efficiently storing electricity and splitting water into hydrogen and oxygen when charged.



A consortium of more than 30 public and private partners, headed by DNV and glass manufacturer Celsian, has set up a two-year programme aimed at developing new industrial burners for high-temperature production processes. Its goal is to facilitate a fast and cost-efficient transition from natural gas to hydrogen.



Large-scale adoption of hydrogen as a transport fuel requires new technology for filling stations. Several companies, including HyET and Resato, have developed proven solutions for some of the related challenges, such as the need for affordable and reliable high-pressure compressors.



Built by Dutch shipyard Concordia Damen, this inland vessel is 100%-hydrogen-powered and 135-metre-long, which transports salt from Delfzijl to Rotterdam. Project partners are the NPRC, Lenten Shipping and engine supplier Koedood Marine Group.



# Dutch hydrogen flagship projects

Flagship projects in the Netherlands show our efforts to improve current technologies of hydrogen production in different ways. These technologies could help solve issues in the global development of hydrogen by working together in partnerships with foreign industries, governments, research institutions and businesses. That way, our shared challenge of limiting the effects of climate change can be tackled together with partners all over the world.



## Sinnewetterstof

Duration: Operational since 2022

Partners: Alliander and GroenLeven

SinneWetterstof means solar hydrogen in Frisian. This pilot project is a collaboration between network company Alliander and renewable energy developer GroenLeven. Right next to the 50MW solar park developed by GroenLeven, there is an electrolyser with a capacity of 1.4 megawatts. Alliander realizes the complete installation of the electrolyzer and leases it to GroenLeven, which buys the energy and sells the hydrogen. Both companies are investigating how hydrogen can play a role in areas where the capacity of the electricity grid is not sufficient to return large-scale generated solar energy. DEP Duurzaam Energie Perspectief has supervised the design, engineering, and realization from start to finish. The control system is designed and implemented by DEP with the aim of being maximally flexible in controlling the installation to optimize the experiments. In March 2022, the installation producing renewable hydrogen was opened. GroenLeven will supply the hydrogen to Orange Gas, which will supply hydrogen filling stations with tube trailers. It is expected that 100,000 kilograms of hydrogen can be produced annually. This amount is good for approximately 10 million clean kilometers with a passenger car. Daan Schut, CTO of Alliander: "By using the generated electricity from the solar park to produce hydrogen and using it as a fuel to drive cars, our grid is less burdened and no green generated energy is lost."

[www.sinnewetterstof.nl](http://www.sinnewetterstof.nl)



## H2 Barge 2

Duration: Completion in 2024

Partners: Future Proof Shipping, Ballard, VTT, Air Liquide, SEAM, Holland Shipyards, Oechies Elektrotechniek.

The H2 Barge 2 is an ambitious project by Future Proof Shipping (FPS) to launch the first hydrogen-powered vessel that will ship goods completely emission-free on the Rhine between Rotterdam (NL) and Duisburg (DE). This project will be a key milestone in the decarbonization of Rhine shipping where roughly 80% of cargo flows are between Rotterdam and Duisburg. The H2 Barge 2 is part of EU-funded FLAGSHIPS project, and the Interreg-funded ZEM Ports NS.

The H2 Barge 2 will also be one of the first commercial pilot vessels for a carbon insetting programme that is being pioneered in collaboration with the CONDOR H2 project and RH2INE initiative.

About FLAGSHIPS:

The FLAGSHIPS consortium includes 12 European partners. The FLAGSHIPS project will take zero-emission waterborne transport to an entirely new level by deploying two commercially operated hydrogen fuel cell vessels.,)

About ZEM Ports NS:

The ZEM Ports NS project consortium consists of seven organizations from Europe and the UK. The project facilitates the use of zero emission fuels (electric and hydrogen) in the NSR ports and maritime sector. The project looks at the role of ports in the interface between zero emission vessels and port infrastructure. It especially addresses the integration of zero emission fuels into the port refuelling infrastructure and local energy systems as well as port and on-ship energy storage.

[www.Flagships.eu](http://www.Flagships.eu)

[www.northsearegion.eu/zem-ports-ns](http://www.northsearegion.eu/zem-ports-ns)





## PosHYdon

Duration: Completion 2024

Partners: Nel Hydrogen, InVesta, Hatenboer, Iv-Offshore & Energy, Emerson Automation Solutions, NexStep, TNO, Neptune Energy, Gasunie, Noordgastransport (NGT), NOGAT, DEME Offshore, TAQA, Eneco

The pilot PosHYdon is the ultimate example of system integration in the North Sea. It is a world's first that green hydrogen will be produced offshore on an operational platform. Together with our partners, we believe that green hydrogen is vital to the energy transition. PosHYdon will teach us a lot about the next steps needed to be taken towards safe, large-scale green hydrogen production at sea. Offshore green hydrogen production will enable large-scale wind farms to be developed far out at sea. Wind energy is then directly converted to green hydrogen and can be transported through the existing gas infrastructure. As a result, offshore wind projects can be realised faster at significantly lower costs for the end users. PosHYdon aims to integrate three energy systems in the North Sea: offshore wind, offshore gas and green hydrogen. All by producing green hydrogen from demineralised seawater on Neptune Energy's Q13a-A platform.

"The Netherlands is in a special position as, in addition to an extensive gas infrastructure network, we can harvest large amounts of wind energy in the North Sea, quantities that are also important internationally. The wind energy can be used to produce hydrogen, which can then be transported onshore along with natural gas via existing pipelines for industry, the transport sector and Dutch homes. PosHYdon is key to accelerating this."

[www.poshydon.com/en/home-en/](http://www.poshydon.com/en/home-en/)



## Holland Hydrogen I

Duration: Completion 2025

Partners: Over 150 partners, e.g. Thyssenkrupp, Worley, Gasunie, Port of Rotterdam, Visser & Smit bouw, Evides, Howden, Conpacksys, Siemens, Kraayvanger, Volker Energy Solutions, FBM Hudson

Shell, together with contractors and vendors, is building the first big renewable hydrogen plant of Europe (200 MW). Once operational in the second half of this decade, it will produce up to 60 tons of hydrogen per day. This is the equivalent of what 2,300 hydrogen trucks will need and is powered by offshore wind produced at the North Sea.

The Holland Hydrogen 1 (HH1) factory rises behind the dunes of the Dutch coast, at the Tweede Maasvlakte plains near Rotterdam, on land reclaimed from the sea. This is a significant Shell investment with financial support from the Dutch government and the European Union through IPCEI, and an endeavour involving more than 150 contractors and vendors.

The project provides an answer to the need for cleaner energy in heavy-duty cargo and industries, sectors that have limited options for other renewable solutions. The design incorporates circular materials wherever possible. The space around the plant will be turned into green retreats for birds and other small animals – to showcase how factories can be, and should be, built.

The HH1 project kickstarts the hydrogen economy of the Netherlands and will speed up society on its path to net-zero emissions by 2050 or earlier, including Shell's own operations and that of Shell clients and partner companies.

[www.shell.nl/energie-en-innovatie/waterstof/welkom-waterstof.html](http://www.shell.nl/energie-en-innovatie/waterstof/welkom-waterstof.html)



## Fountain Fuel Amersfoort

Duration: Operational since 2023

Partners: Fountain Fuel, Allego, Linde

Fountain Fuel develops a network of 100% zero-emission energy stations where e-charging and green hydrogen are combined. Our first station in Amersfoort is operational since May 2023 and already has an uptime of 98.35%. The Fountain Fuel Amersfoort project acts as the blueprint for our future stations in Europe. In Amersfoort, Fountain Fuel controls and combines technique, exploitation, realisation and operations. Leading to a reliable, outspoken and flawless experience at our station.

Key features of the Amersfoort-project are the separation of both light- and heavy duty traffic, with 350 and 700 bar refuelling and a fully redundant design.

- By working together with OEM's to stimulate the supply of vehicles, whilst simultaneously realizing reliable hydrogen refuelling infrastructure, we effectively break through the 'chick-or-egg' problem. This results in scale- and costs advantages for all parties in the supply chain.
- Through the HyVan project (completed in Q4 2023), which was a collaboration between Fountain Fuel – Allied Waters – Renault Hyvia – and Stellantis, we have taken the first hydrogen-powered business vans of The Netherlands in operation together with regional entrepreneurs. The project was made possible by EFRO.
- The next zero-emission energy stations, Nijmegen and Rotterdam, are scheduled for completion in Q1 2025. These projects will adhere to the new SAE refuelling standard, further accelerating the adoption of the hydrogen economy and allowing businesses to work towards zero-emission logistics solutions.

With the insights and knowledge from this station and the linked projects, we will roll out a network of zero-emission energy stations throughout Europe – connecting the entire value chain from industry, to fleet-owner, to manufacturer, to government, to supplier.

[www.fountainfuel.com/en/](http://www.fountainfuel.com/en/)





# Mission H2: The Hydrogen Map

Mission H2 is an initiative by a consortium of Dutch organisations aiming to foster the development of hydrogen and for the larger public to become more acquainted with the subject. Specifically, the goal is to work with the government and a large number of Dutch companies to endorse a fully functioning hydrogen market by 2030.

The Hydrogen Map, developed by Mission H2 together with TKI New Gas, contains the most comprehensive and up-to-date map of the Netherlands with the many initiatives that already exist in the field of hydrogen.

Moreover, the interactive map offers the unique opportunity to travel through time to see the development of hydrogen projects in the Netherlands. Scan the QR-code to:

- Discover all projects in the hydrogen value chain
- See at a glance the status of every hydrogen project
- Travel to 2030 to see how the Netherlands is developing
- Dive into the dashboard statistics of the hydrogen map

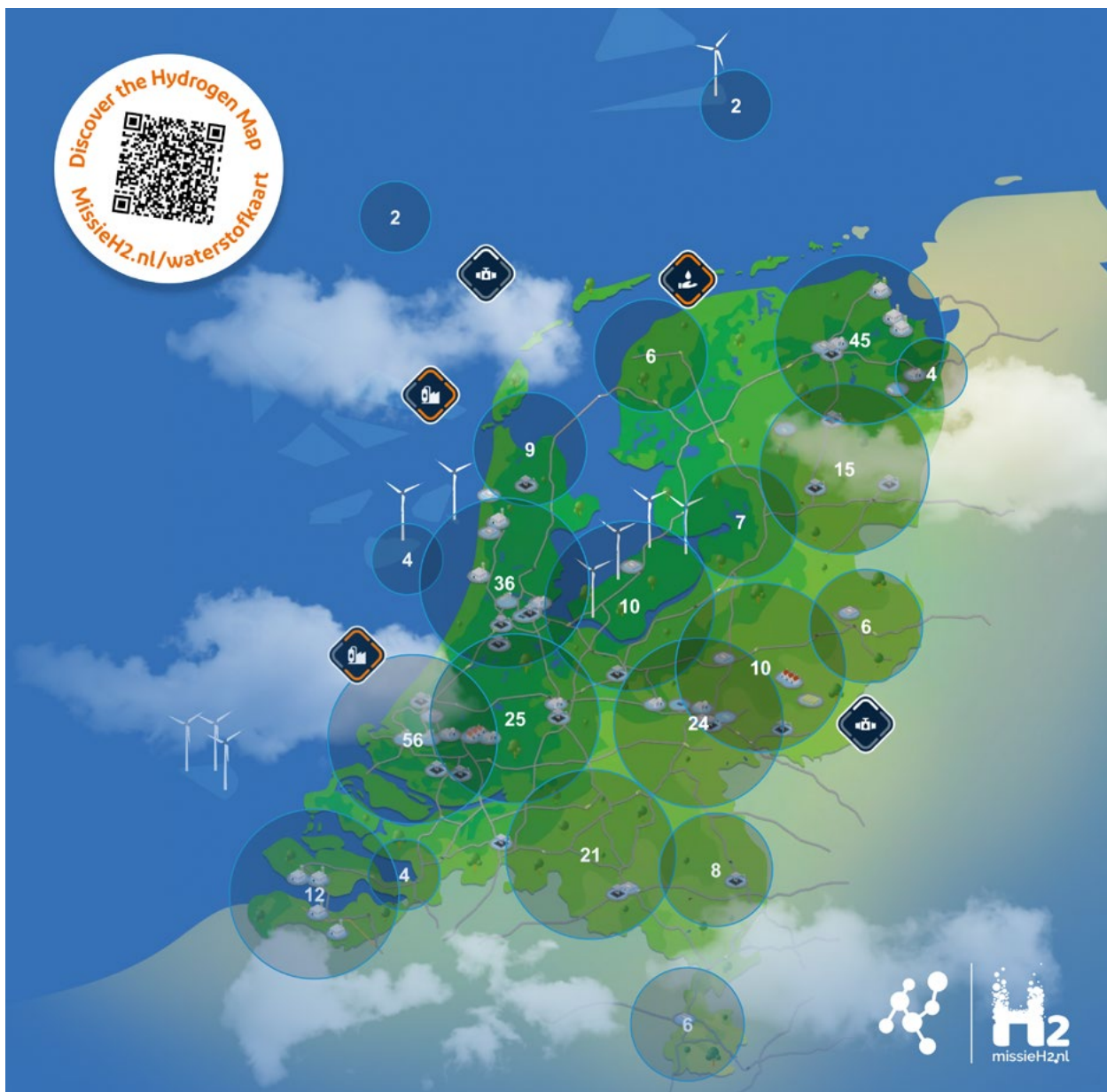

# Partners for International Business (PIB)

# Creating solutions for a hydrogen-powered economy together

The Dutch government has developed multi-annual action plans with clusters of Dutch businesses and knowledge institutes. The purpose of these plans list strategic activities in the hydrogen sector that provide the Dutch hydrogen industry with best possible platform abroad for international cooperation. These collaborations present an opportunity for Dutch and international companies in the hydrogen chain to exchange knowledge, share innovative ideas and build partnerships. This includes sharing know-how on hydrogen developments from supply chains (production, transportation and storage) to usage and applications (mobility, built environment, and energy and industrial sectors).

## Australia

The capabilities of this cluster of Dutch hydrogen experts in the PIB H2 Australia span the entire hydrogen chain. Together, the partners can help Australia realise its ambitions to produce and export clean hydrogen to the global market. This partnership is coordinated by New Energy Coalition. Elestor, Metalot, Soluforce, Vopak, Arcadis, Port of Rotterdam, Prodrive Technologies, TES and TNO are cluster member.

## Chile

Chile is to be a competitive exporter of green energy and the focus of this PIB programme is to build connections between Dutch hydrogen companies with the Chilean hydrogen market, with a strong emphasis on companies that are active in port logistics, port infrastructure and storage. This partnership is focused on the two main potential 'hydrogen hubs'; the Southern Magallanes and Northern Antofagasta region. Rotterdam Partners is the coordinator of this PIB. Arcadis, Gasunie, Port of Rotterdam, Port Consultants Rotterdam, Proton Ventures, Soluforce and Vopak are cluster member.

## Gulf Region

The Gulf region is well positioned to become a net exporter of clean hydrogen and its derivatives at globally competitive costs. Their ability to scale up clean hydrogen production makes these Gulf states the ideal breeding ground for developing clean hydrogen value chain-related technology from pilot to commercial scale. The PIB will help to enable business opportunities related to the development of the hydrogen value chain, including creating required corridors to transport hydrogen or derivatives from the Middle East to Europe. The cluster of more than 30 companies is coordinated by Holland Hydrogen Hub. Advorio, Air Products Nederland, Battolyser, Bosal, Boskalis, Demaco, Desolenator, DOT Power, Elestor, Gasunie, H2Fuel, HaskoningDHV Nederland BV (Dubai Branch), HyET Group, Hy-gro, Invest International, IRO, J. de Jonge - Next gen connectors, NES Fircroft, Nonox, Plug Power, Port of Amsterdam, Port of Rotterdam, Proton Ventures, Roland Berger, Soluforce, Stirling Cryogenics, Thomassen Energy, TNO, UMS, Vopak, Voyex and Witteveen+Bos are cluster member.

## Japan

Both the Netherlands and Japan have a strong industry in the field of hydrogen and a high development potential. Through innovative cooperation, both countries can strengthen each other in the developments surrounding both the supply of hydrogen and large-scale and broad applications of hydrogen - in particular applications in industry, mobility and the built environment. New Energy Coalition is coordinating this cluster. Bronkhorst, Duiker Combustion Engineers, FUJIFILM Manufacturing Europe, Holthausen Clean Technology, Howden, Kiwa, SoluForce, TES, TNO, Hydrogen Architects, Proton Ventures and Vopak are cluster member.

For more information about Partners for International Business and the clusters mentioned here, see our initiatives on [TradewithNL.nl](https://TradewithNL.nl) or contact us at [pib@rvo.nl](mailto:pib@rvo.nl).



Scan the QR code  
for more information



# Five benefits of doing business with the Netherlands







### **1. Quality and reliability**

We combine first-class technical expertise and innovative strength with a commitment to delivering high-quality, reliable products and solutions. Working with Dutch technology means you can be certain of compliance with the highest (European and international) standards.

### **2. An international outlook**

We have been doing business abroad for centuries and understand what it takes to work successfully across borders and cultures. We are also regularly ranked as having the world's most proficient non-native English skills.

### **3. High-tech excellence**

The Netherlands has a long history in high-tech innovation. In terms of the number of patents per capita, we rank second in the world and we are home to world-class research institutes in clean energy technology, global players in semiconductor technology and excellent machine manufacturers.

### **4. Joint innovation**

We strive to create flexible, fast-moving networks of specialist companies and research institutes and are proud of the dozens of 'field labs' in which such networks translate fundamental research into innovative solutions and test them in real-life pilot environments.

### **5. Easy access to specialist expertise**

We have organised our clean energy expertise into national consortia. These networks offer fast and easy access to the right technology providers, researchers or combination of specialists. We all pursue a common goal: solving global challenges together.



# Dutch hydrogen expertise

Looking for specific expertise or technological solutions? In this section, Dutch businesses and other organisations in the Dutch hydrogen sector introduce themselves and their portfolios. Consult the table on p. 32/33/34 to identify possible partners in your future hydrogen endeavours.

# Creating international partnerships is essential to stimulate the global hydrogen economy

Nations worldwide are in transition towards a renewable-powered energy system to fight the threat of global warming. The latest IPCC report stresses the urgency to increase the speed and scale of renewable deployment to reach the goals of the Paris Agreement.

Hydrogen can, and - in my opinion - will play a key role in achieving the transition towards a climate-neutral and circular economy. Hydrogen has a multitude of potential applications across energy-intensive sectors. It can be used as feedstock and it can replace fossil fuels in high-temperature processes in our industry.

Due to its high-energy density, it is suitable for long-distance transportation purposes, and it can partially play a role as sustainable backup energy source for longer term, seasonal storages.

However, truly incorporating hydrogen into the global energy system remains challenging. The large-scale (sustainable) hydrogen production, development of a new European and international infrastructure, and a global hydrogen market are still in the early stages of development. This market is expected to become similar in form and magnitude to the current oil and gas markets. Especially because the climate challenges are global and hydrogen is only one of few alternatives available.

To achieve a truly integrated hydrogen system, it requires a cooperating international community. The Netherlands' enormous experience with natural gas, as the "gas roundabout" of North-West Europe, makes it an ideal and willing candidate for a substantial and constructive role within a hydrogen-based economy. Our ports and the fact that we are well-connected to other Northwest European countries provide a geographically strategic position that we can use to become the center of a European and perhaps a global hydrogen market. Furthermore, Dutch knowledge institutions and regional ecosystems, such as the green hydrogen valley, are extremely effective in translating ideas into practice within and outside the Netherlands. As this brochure illustrates, the Netherlands is also home to a wide variety of ambitious companies, ready to kick-start the European and global hydrogen market. In that perspective, I'm proud of the Dutch ambition to lead the development of hydrogen markets.

Activity in the Netherlands related to technological innovation and business developments is increasing. Creating international partnerships is essential to stimulate the development of a global hydrogen economy. It is our joint responsibility to turn initiatives into concrete projects and operational systems and thereby demonstrating hydrogen's full potential in a sustainable energy system.

We understand that realising hydrogen's full potential will take time in which considerable challenges must continuously be overcome. Our aim is to support you in achieving your projects, ambitions and goals.

**Peter Molengraaf**  
Chair Energy Innovation NL





	ELECTRICITY	H <sub>2</sub> PRODUCTION	ENGINEERING / INSTALLATION	INFRASTRUCTURE	FLOW SOLUTIONS	STORAGE	MOBILITY	MARITIME	INDUSTRY	BUILT ENVIRONMENT	INFRASTRUCTURE AND STORAGE	RESEARCH / ADVISORY	ASSOCIATION	PAGENUMBER
&Flux														35
20K Hydrogen B.V.				•	•		•	•	•		•			35
ABB	•	•	•	•	•	•	•	•	•	•	•			36
ABC-Techniek B.V.			•		•		•	•	•		•			36
Adsensys H2 Solutions		•	•				•	•	•	•	•	•		37
AECOM	•	•	•	•		•	•	•	•	•	•	•		37
AEG Power Solutions B.V.	•	•	•						•	•				38
Air Liquide		•	•	•	•	•	•	•	•	•	•	•	•	38
Air Products Netherlands B.V.		•	•	•		•	•	•	•	•	•			39
Alkalium B.V.		•	•			•								39
AMF Bakery Systems – AMF Den Boer									•					40
Ansaldo Thomassen B.V.									•					40
Antonius				•		•		•			•			41
AquaBattery B.V.		•				•		•	•	•	•	•		41
Arcadis			•	•			•		•	•	•	•		42
AVK Nederland BV			•		•				•	•	•			42
Avox B.V.		•	•				•	•	•	•	•			43
AWL Techniek B.V.			•						•			•		43
BA2C														44
Battolyser B.V.	•	•	•			•	•		•	•	•			44
Berenschot												•		45
Bilfinger Engineering	•	•	•	•		•			•		•			45
Bosal	•	•					•	•	•	•	•			46
Bosch Rexroth B.V.				•	•	•	•	•	•	•	•			46
Bosch Thin Metal Technologies			•			•	•	•	•	•	•	•		47
Bredenoord	•						•		•	•	•			47
BrigH2		•					•		•			•		48
Bronkhorst Nederland B.V.		•	•	•	•		•	•	•	•	•	•	•	48
Brunel														49
Bureau Veritas		•	•	•		•	•		•	•	•	•		49
Bürkert Fluid control systems		•			•		•	•	•	•	•			50
Stichting Cenex Nederland (Cenex NL)							•					•		50
Circonica Circular Energy BV	•	•	•			•	•	•	•	•				51
CLEAR												•		51
CoheSys												•		52
Connectr - Energy innovation	•	•	•	•	•	•	•	•	•	•	•	•	•	52
ConPackSys B.V.			•	•	•	•			•		•			53
Corre Energy Storage						•								53
Cryoworld				•	•	•	•	•	•	•	•	•		54
Danfoss B.V.	•	•	•	•	•	•	•	•	•	•	•	•		54
De Boer SPS		•	•	•	•	•	•		•	•	•			55
Deelnijk   hydrogen & experts		•	•	•		•	•	•	•			•		55
Deerns		•	•	•	•	•			•	•	•	•		56
Deltalinqs													•	56
Demaco Holland B.V.			•		•		•	•	•		•	•		57
Demcon		•	•				•		•			•		57
Desu Systems B.V.		•				•	•	•	•	•	•	•		58
DLS – Drive Line Systems							•	•	•	•	•	•		58
Doeko B.V.		•	•	•		•		•	•	•	•			59
Douna Machinery B.V.		•	•		•	•			•	•		•		59
Duiker Combustion Engineers			•			•			•	•		•		60
Dumaco Woerden B.V.			•											60
Dutch Boosting Group							•		•	•	•	•		61
Dutch Marine Energy Centre (DMEC)	•	•	•					•	•	•	•	•		61
DWG	•	•	•		•	•	•	•	•	•	•	•	•	62
E&E advies												•		62
Eekels Technology B.V.	•					•		•	•		•	•		63
Ekinetix B.V.	•	•	•	•	•	•	•	•	•	•	•	•		63
Ekwadraat Advies BV												•		64
ElecHydro BV		•												64
Elestor BV		•				•			•	•				65
Eltacon Engineering BV	•	•							•		•			65
Emmett Green	•	•	•	•		•	•	•	•	•	•	•		66
Enablemi												•		66
Endress+Hauser					•									67
ENERCY B.V.			•	•								•		67
Energy Storage NL													•	68
ENGIE Services Nederland N.V.	•	•			•		•	•	•	•		•		68
ENTRANCE   Centre of Expertise Energy		•	•	•	•		•	•	•	•	•	•		69
EoxTractors B.V.							•		•	•				69
Erez Energy		•					•		•	•				70
ERIKS Nederland	•	•		•	•	•	•	•	•	•	•			70
E-Trucks Europe B.V.							•							71
EY   Ernst & Young												•		71
Feenstra			•							•				72
Technology Centre Europe Van der Kloek Beheer BV / FINN BV		•					•	•				•		72
Fluidwell B.V.		•	•	•	•				•	•	•			73
Fluor		•	•	•	•	•			•	•	•	•		73

	ELECTRICITY	H <sub>2</sub> PRODUCTION	ENGINEERING / INSTALLATION	INFRASTRUCTURE	FLOW SOLUTIONS	STORAGE	MOBILITY	MARITIME	INDUSTRY	BUILT ENVIRONMENT	INFRASTRUCTURE AND STORAGE	RESEARCH / ADVISORY	ASSOCIATION	PAGENUMBER
FME														74
Fountain Fuel				•			•						•	74
Frames Renewables		•					•	•	•	•	•			75
Fujifilm		•										•		75
Future Proof Shipping							•	•	•	•		•		76
N.V. Nederlandse Gasunie				•		•								76
gAvilar B.V.			•	•					•	•		•		77
GF Piping Systems		•		•	•			•	•		•			77
Green Energy Park Global B.V		•				•			•		•			78
Platform Groene Hart Werkt!													•	78
Groningen Airport Eelde NV	•	•		•			•					•		79
Groningen Seaports	•	•	•	•	•	•	•	•	•		•	•		79
H2ARVESTER	•	•	•				•	•	•		•	•		80
H2 Circular Fuel B.V.		•				•	•	•	•	•	•			80
H2Dock BV		•												81
H2Hub Twente	•	•		•			•		•	•	•	•		81
H2Makers													•	82
H2O Systems Holland BV		•		•						•	•	•		82
H2Storage B.V.			•	•		•	•	•	•	•	•			83
HAN University of Applied Sciences				•			•	•	•	•	•	•		83
Heattec Heat Technology B.V.		•	•					•	•	•				84
Hinicio												•		84
Hint Global B.V.														85
Hobre Instruments B.V.	•	•							•					85
HOWDEN				•	•	•	•	•	•		•			86
HSM Offshore Energy BV		•	•						•					86
Hy-Cell Co. Ltd.	•						•	•	•			•		87
HyCC		•							•					87
HyDevCo B.V.		•	•				•	•	•	•				88
Hydrasun BV		•	•	•	•		•	•	•		•			88
Hydrogen Architects		•	•	•		•	•	•	•		•	•		89
Hydrogen Powered Solutions BV		•	•	•		•	•	•	•	•	•	•		89
TU Delft Hydro Motion Team					•	•	•	•		•	•	•		90
Hydron Energy		•					•	•	•	•	•			90
Hydronex B.V.	•	•		•			•	•	•			•		91
HyEnergy Consultancy (Europe) BV		•	•	•		•	•	•	•		•	•		91
HyET Hydrogen B.V.		•	•	•	•	•	•	•	•	•	•	•		92
HyGear		•	•	•	•	•	•	•	•	•	•	•		92
HyMatters Operations B.V. / HyMatters Research & Consultancy B.V.	•	•	•	•	•	•	•	•	•	•	•	•		93
HyMove B.V.							•	•	•					93
HyNorth												•	•	94
HyPlanet BV		•		•		•	•	•	•					94
Hysolar		•		•			•	•				•		95
Hystream B.V.	•	•	•	•		•	•	•	•	•	•	•		95
Institute for Sustainable Process Technology (ISPT)									•			•		96
Iv-Groep b.v.	•	•	•			•								96
Invest International	•	•	•	•	•	•	•	•	•		•			97
JP Energy Systems		•	•	•		•	•	•	•	•				97
Kapp Nederland B.V.		•	•		•		•	•	•	•				98
Kelvion B.V. - Kelvion Thermal Solutions		•	•			•	•		•		•			98
Kenter B.V.				•										99
Kiemt												•	•	99
Kiwa	•	•	•	•	•	•	•	•	•	•	•	•		100
KLINGER The Netherlands		•	•		•				•		•			100
Koedood Marine Group	•	•	•			•	•	•	•			•	•	101
Koninklijke Van Twist	•							•						101
Krock H2 Boats								•						102
MAGNETO special anodes B.V.		•			•		•	•	•	•	•	•		102
Magnus Energy B.V.				•					•		•	•		103
Marsh Netherlands						•			•		•	•		103
Mechatest Sampling Solutions									•					104
Metalot Future Energy Lab												•		104
Mokveld Valves BV					•				•		•			105
Mott MacDonald BV		•	•	•	•	•	•	•	•		•	•		105
MTSA Technopower B.V.		•				•	•	•	•	•	•			106
Micro Turbine Technology B.V. (MTT)	•	•	•						•	•		•	•	106
MV Energietechniek	•	•	•	•	•	•	•	•	•	•	•	•		107
Neptune Energy Netherlands B.V.		•	•	•		•					•	•		107
Netherlands Enterprise Agency (RVO)													•	108
Nettenergy B.V.	•	•	•									•		108
New Cosmos - BIE	•	•				•	•	•	•	•	•	•		109
New Energy Business School							•	•	•	•	•	•	•	109
New Energy Coalition		•		•		•	•	•	•	•	•	•	•	110
Nexus Energy B.V.			•	•				•	•	•	•			110
NGT BV		•		•	•	•			•		•			111
Development Agency North Holland North (NHN)							•	•	•	•		•	•	111
NLHydrogen													•	112



	ELECTRICITY	H <sub>2</sub> PRODUCTION	ENGINEERING / INSTALLATION	INFRASTRUCTURE	FLOW SOLUTIONS	STORAGE	MOBILITY	MARITIME	INDUSTRY	BUILT ENVIRONMENT	INFRASTRUCTURE AND STORAGE	RESEARCH / ADVISORY	ASSOCIATION	PAGENUMBER
NOGAT B.V.	•	•		•		•					•			112
North Sea Port				•				•						113
Nuvera Fuel Cells Europe	•						•	•	•					113
Netherlands Hydrogen & Fuel Cell Association NWBA												•		114
NXT Mobility				•			•							114
OCI Global		•		•			•	•	•					115
ON2Quest		•	•				•	•	•	•		•		115
Pondera (Consult B.V.)	•	•	•			•	•	•	•	•	•	•	•	116
Port of Amsterdam	•	•		•			•	•	•	•	•			116
Port of Rotterdam	•	•		•			•	•	•	•	•			117
Power2X		•		•		•	•	•	•	•	•	•		117
Pro Control Process Automation BV					•		•	•	•					118
Prodrive Technologies B.V.	•	•		•					•		•			118
Proton Ventures BV			•			•		•	•			•		119
Pure Water Group	•	•	•					•						119
PwC												•		120
RAI Automotive Industry NL							•	•	•			•	•	120
RAP Clean Vehicle Technology							•		•		•	•		121
REDstack B.V.	•	•			•				•					121
Remeha			•							•		•		122
Resato International			•	•			•							122
RN Solutions B.V.									•					123
Royal HaskoningDHV												•		123
RWE	•	•				•	•	•	•					124
SALD bv			•				•	•	•	•		•		124
Samotics									•					125
Saxion University of Applied Sciences							•	•	•	•	•	•		125
Schaeffler Nederland B.V.		•					•	•	•	•	•			126
Schwank BV		•	•	•	•			•	•	•	•	•	•	126
SHV Energy N.V.				•		•	•		•	•	•			127
Sia Partners	•	•	•	•	•							•		127
Siemens Energy B.V.	•	•	•	•		•	•	•	•		•			128
Solstice Management B.V.												•		128
SoluForce B.V.				•	•						•			129
Sorama B.V.	•	•	•	•	•	•	•	•	•	•	•	•	•	129
SparkNano			•						•			•		130
R. Stahl Electromach				•			•	•	•	•	•	•		130
Stork			•	•	•			•	•	•	•	•		131
Strohm BV					•	•		•	•	•	•			131
Summit Engineering B.V.		•	•	•		•	•	•	•	•	•	•		132
SuWoTec B.V.		•					•	•	•	•	•	•		132
Swagelok Nederland					•		•	•	•	•	•	•		133
Tebulo Engineering	•	•	•	•	•	•	•	•	•	•	•	•		133
Teesting B.V.			•		•		•		•					134
T.EN Netherlands B.V.		•	•						•			•		134
TKI New Gas (Topsector Energy)												•		135
TNO Process Safety Solutions												•		135
To70 aviation												•		136
Torgas bv		•	•						•			•		136
Toyota Material Handling							•		•			•		137
Tradinco Instruments					•		•	•	•	•	•	•		137
TSG Group			•						•			•		138
TSG Netherlands BV		•				•	•	•	•	•	•	•		138
TU Delft	•	•		•	•	•	•	•	•	•	•	•		139
TwynstraGudde	•	•	•	•			•	•	•	•	•	•	•	139
Van Campen Ecotechniek B.V.							•							140
VARO Energy Netherlands B.V.		•							•					140
VDL Energy Systems B.V.			•			•	•	•	•	•	•			141
Veco B.V.		•					•	•	•	•	•			141
Vecom Group B.V.		•		•	•	•	•	•	•	•	•			142
VEGA level and pressure	•	•		•	•	•		•	•	•	•			142
Volth2		•					•	•	•					143
VONK	•	•							•	•				143
Royal Vopak				•	•	•	•	•	•	•	•			144
Voyex B.V.						•	•	•			•			144
VTTI		•		•	•	•	•	•	•	•	•			145
Water Alliance													•	145
WE   doubleyouenergy B.V.		•	•			•	•	•	•	•	•			146
Wigersma & Sikkema B.V.					•						•			146
Witteveen+Bos	•	•	•	•				•	•	•	•	•		147
WSP	•	•	•	•	•	•	•	•	•	•	•	•	•	147
XINTC		•					•	•	•	•	•			148
zepp.solutions	•						•	•	•	•	•	•		148
Zeton BV		•							•			•		149

## &Flux

Nicole van Klaveren  
Goudsesingel 128  
3011 KD Rotterdam  
The Netherlands

+31 (0)6 2322 7819  
www.nflux.nl  
nicole@nflux.nl



Building new value chains, starting with 'proof of concept' and strong stakeholder engagement – that is what drives us. We understand the complexity of transitions and know how to bring market, government, innovations, business cases, technology and policy together. In each of our focus fields - energy transition, feedstock transition, circularity and climate adaptation – we have developed and initiated programs with a multitude of partners from business, government and society. Examples include the boosting of sustainable heat projects in eg the Amsterdam metropolitan area, CO2 as a feedstock for future proof industry, market for re-use of solar panels and developing international hydrogen value chains.

&flux initiated several international hydrogen value propositions, like an industrial hydrogen import

chain between North Africa and the Netherlands. In Estonia we established the hydrogen strategy for Port of Tallinn. Through cooperation with business and government partners we kick-started the build of a new economic proposition with Port of Tallinn as the central node in the hydrogen ecosystem. We extended this into a hydrogen action perspective for the Estonian aviation cluster. Recently, we started to explore a joint collaboration platform and hydrogen strategy for Klaipeda (port, municipality and FEZ) region in Lithuania. The ultimate goal of these projects is to enable companies and governments to establish hydrogen projects along the full value chain. In the Netherlands, &flux initiated and is leading the H2Makers platform ([www.h2makers.nl](http://www.h2makers.nl)), connecting entrepreneurs, corporates, education institutions, experts, governments and suppliers for the hydrogen manufacturing industry.

## 20K Hydrogen B.V

Gerhard Knoll  
Havenweg 14  
1771 RW Wieringerwerf  
The Netherlands

+31 (0)228 74 39 30  
www.20K-hydrogen.com  
g.knol@20k-hydrogen.com



20K Hydrogen : the supplier for high-end LH2 cryogenic products. The company was founded in 2021 as spinoff of Cryoworld, to deliver its innovations as series produced, repeatable, high quality, certified and tested products to the market. In order to make the energy transition possible we are convinced that delivery of products for liquid Hydrogen is an important piece of the puzzle due to its high energy density and quick response to load changes. We want use our decades of cryogenic engineering and building experience to make the energy transition a success.

We deliver various essential products and components in the liquid hydrogen supply chain. Examples are;

Liquid hydrogen storage solutions, volumes up to 10.000 L in vertical or horizontal design (scalable, larger upon request), low boil-off design based on scientific helium experience

- Small-scale LH2 movable storage dewar
- Sturdy LH2 storage tank for mobile and static applications

- LH2 lightweight aluminium tank for mobile applications such as aviation.

Lab scale liquefier HYQUE L50, liquefaction capacity 10 kg/day, storage capacity 500 L (scalable, larger upon request)

Liquid hydrogen distribution systems

- Lab scale LH2 testing systems
- LH2 Filling station
- LH2 flexible transfer line
- LH2 Johnston coupling

From our first-line experience, we know that properly build liquid hydrogen equipment is a substantial part of the solution to the climate challenges the world is facing. Therefore, we see it as our obligation to contribute to accelerate the introduction of liquid hydrogen solutions. 20K Hydrogen : the next step in green H2 energy





**ABB**

Martijn Schager, Bas Kluit,  
Mohamed Tajjiou, Reinier Hamming  
George Hintzenweg 81  
3068 AX Rotterdam  
The Netherlands

+31 (0)800 9103  
new.abb.com/drives/segments/hydrogen  
contact.center@nl.abb.com



ABB is a leading global technology company that energizes the transformation of society and industry to achieve a more productive, sustainable future. By connecting software to its electrification, robotics, automation and motion portfolio, ABB pushes the boundaries of technology to drive performance to new levels.

With a history of excellence stretching back more than 130 years, ABB's success is driven by about 110,000 talented employees in over 100 countries. ABB's broad portfolio encompasses the full hydrogen value chain from production, transportation, storage to consumption. We are working closely with partners and our customers to create the new hydrogen ecosystem.

**ABC-Techniek B.V.**

Rob van Dijk  
Coenecoop 58  
2741 PD Waddinxveen  
The Netherlands

+31 (0)182 634 139  
www.abc-techniek.com  
info@abc-techniek.com



Over a period of three decades ABC-Techniek became a well-known and established system integrator for customers around the world.

Work together to find the best solution and a no-nonsense mentality are important factors that contribute to the growth of our company. Besides this our technical know-how, high internal standards of quality and the passionate drive for our areas of expertise are indispensable. Therefore, we can call ourselves an innovative player in the field of engineering, fabrication of control systems and electrical and instrumentation (E&I) installations.

ABC-Techniek is an ISO-9001 certified organisation with a proven knowledge along with experience in the design as well as delivery of

control- and distribution panels for a power supply up to 690VAC and 3200A. Furthermore an extensive experience in wiring of electrical and instrumentation installations and finally an expertise in explosion protection. Our professional knowledge offers you an integral approach from the designing process to realization, pre-operational and start-up, maintenance and services.

ABC-Techniek provides products and services for the hydrogen and renewable energy industry, petrochemical and process industry (ATEX/IECEX). Our staff is certified to execute inspections in particular on electrical installation in hazardous locations. The professional competence is warranted by the IECEX 05 Certification of Personnel Competence (CoPC).

## Adsensys H2 Solutions

Arthur Scheffer  
Korhoenweg 19  
4791RM, Klundert  
The Netherlands

+31 (0) 1683 82700  
www.adsensys.nl  
info@adsensys.nl



Adsensys makes an impact by sharing knowledge about the possibilities and benefits of green hydrogen and offers turnkey solutions for hydrogen production in various sectors such as mobility, industry and agriculture and horticulture with a modular and scalable hydrogen configuration that produces and stores 99.9% clean hydrogen.

Taking the next step in the energy transition - that's what you do when you generate hydrogen with Adsensys' scalable solutions. Our hydrogen products consist of a core, which is then mass-produced. The result? A scalable and flexible solution. Due to scalability, the applications are almost endless. So together, we always find a solution that fits your needs seamlessly.

With a scalable, modular and innovative system, we make green hydrogen accessible to everyone. From 2.4 kilowatts to several megawatts, which can be connected to an infinite number of megawatts. In doing so, we reduce the impact of fossil fuels on the climate and contribute significantly to accelerating energy transition. Together, we make the world a little more beautiful. And that with 99.999% clean green hydrogen.

## AECOM

Adelin Oleş  
Oude Middenweg 17  
2491 AC The Hague  
The Netherlands

+31 (0)6 13 76 63 78  
<https://publications.aecom.com/sustainable-legacies/>  
<https://aecom.com/benelux/>  
adelin.oles@aecom.com



AECOM provides decarbonisation professional and project delivery services to support clients to transition from carbon powered infrastructure to more sustainable alternatives. We help customers to decarbonise portfolios, transition to sustainable alternatives and deliver innovative energy solutions in the production, handling, and usage of hydrogen for a full range of mobility, heating and storage outcomes. We provide single-source multidisciplinary engineering, environmental, project and construction management services across the whole hydrogen value chain. Our combination of global experience and integrated technical capabilities delivers strategic solutions that improve and modernise infrastructure; enhance sustainability and resiliency; and benefit communities.

References:

- EPCM services for Shell's Hydrogen fuel stations (heavy and light duty infrastructure) across Benelux
- Design and delivery of filling points for Qbuzz's fleet of hydrogen-powered buses in Groningen, The Netherlands
- Feasibility and pre-FEED design support for world's first 100% hydrogen-fired gas turbine power station and conversion of an existing CCGT to 50% hydrogen blend in the UK
- Upgrade of Italy's historic Apennine diesel railways to hydrogen train transportation and supporting generation, including supply infrastructure
- Confidential site selection, engineering and feasibility services for blue and green hydrogen production facilities, UK
- Confidential green ammonia import facility environmental permitting and program support



**AEG Power Solutions B.V.**

Robin Lemstra  
Weerenweg 29  
1161 AG Zwanenburg  
The Netherlands

+31 (0)6 53 91 78 56  
www.aegps.com  
sales.nl@aegps.com

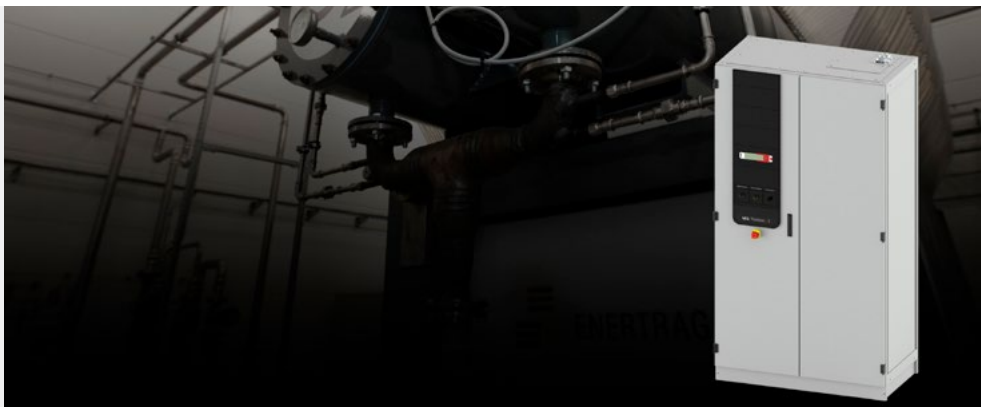

# AEG POWER SOLUTIONS

Since decades, AEG Power Solutions has ensured continuous availability of power and the safe operation of critical applications in all environments thanks to a wide portfolio of power supply systems and services. Our distinctive expertise spans AC & DC technologies and we have developed world-class engineering capabilities that span conventional and renewable energy platforms.

We leveraged our unique power electronics, grid integration and conversion expertise to develop power solutions supporting the energy transition, from wind power generation to energy storage and hydrogen production. AEG PS is a proven specialist for storage converters in On/Off Grid energy storage applications thanks to our bi-directional system, Convert SC Flex.

For hydrogen production, our high current rectifiers Thyrobox DC3 are a solution of choice to supply power for the electrolysis process. We provide the complete power block (transformer + rectifier) solution with the integrated grid compliance requirement and low losses. The power blocks ranges from 500 kW – 10 MW blocks which can be connected together to supply the electrolyser cells for large scale projects above 100 MW. AEG PS is working with electrolyser OEM's, EPC's and integrators to support them with our power solutions. We have been an active player in this field for over 8 years and have developed a field expertise to best support our customers.

**Air Liquide**

Xavier Pontone  
Weena 312-314  
3012 NJ Rotterdam  
The Netherlands

+32 477 44 31 80  
nl.airliquide.com  
xavier.pontone@airliquide.com



# Air Liquide

Air Liquide, your strategic business partner to accelerate a hydrogen society in Europe.

Reducing CO2 emissions has become a major challenge, in particular for industry and heavy-duty mobility key players. To meet this challenge, Air Liquide has a comprehensive portfolio of technology and service solutions to support the decarbonization efforts of its customers around the world, from the supply of low-carbon industrial gas to active CO2 capture.

To decarbonize the planet, hydrogen plays a key role. The Air Liquide Group's unique expertise in this field dates back more than 50 years. Its technologies are widely used throughout the low-carbon hydrogen supply chain, from production to storage and distribution. This

technological expertise has already enabled Air Liquide to forge numerous strategic partnerships to accelerate the activation of hydrogen markets, together with worldwide leading players in key industrial basins.

The momentum is there, and almost everything is actually in place to scale up a hydrogen economy, especially in Europe: early markets coming on stream, initiated efforts to align for deployment, existing supporting policies, a systemic need, a strong technological potential as well as signs of societal acceptance.

Joining forces is essential to accelerate the role of hydrogen in the energy transition!

**Air Products Netherlands B.V.**

Rogier Blokdijk  
 Boyneweg 10  
 3197 LK Botlek-Rotterdam  
 The Netherlands

+31 (0)10 296 06 74  
 www.airproducts.com  
 ninfo@airproducts.com

**H<sub>2</sub>fM<sup>®</sup>**  
 Hydrogen for Mobility



Air Products has been a leading global producer of industrial gases for more than 80 years. With a strong focus on energy, environment and emerging markets, Air Products supplies essential industrial gases and related equipment to dozens of industries including refining, chemicals, metals, electronics and food and beverage.

Air Products is the world's largest hydrogen producer. We believe that hydrogen, the most abundant of all elements, will be the solution – the future of energy. Through our partnerships we are already working towards a hydrogen-based

world where hydrogen and fuel cell technology will play a central role in decarbonizing heavy duty vehicles and industry. Air Products is active throughout the complete hydrogen value chain including production, distribution, storage and dispensing and has been at the forefront of hydrogen refueling for decades. Air Products has experience with more than 250 hydrogen refueling station projects in 20 countries. Air Products' technologies are used in more than 1.5 million refueling operations annually.

**Alkalium B.V**

Rob Vasbinder  
 Burgemeester Colijnstraat 81  
 2771GH Boskoop  
 The Netherlands

+31 (0)6 4293 7974  
 www.alkalium.com  
 energystorage@alkalium.com

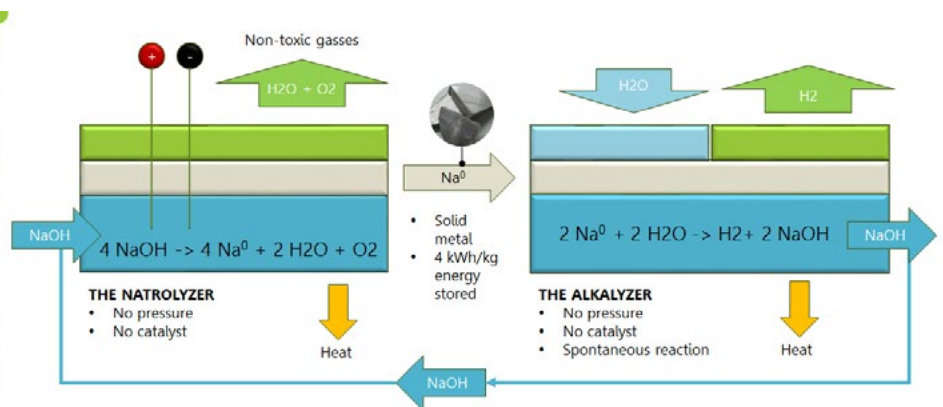

Alkalium supplies an alternative for energy storage. Our energy storage is using Sodium metal. Our solution is based on the Alkalium process. The Alkalium process is based on two devices: The Natrolyzer to convert electrical energy in sodium metal from sodium hydroxide and the Alkalyzer to convert sodium to hydrogen and sodium hydroxide by applying water. The sodium hydroxide is then returned to the Natrolyzer. With Sodium metal we can span energy storage from hours, months into years. We can also have the Natrolyzer operating in one country and have the Alkalyzer in another country due to the high energy density of the Sodium metal which makes transport feasible using

existing infrastructure and transport facilities.

Alkalium offers both the Natrolyzer and the Alkalyzer and is open to technology agreements to allow local manufacturing of these devices.



**AMF Bakery Systems – AMF Den Boer**

Lex van Houten  
Edisonweg 50  
4207 HG Gorinchem  
The Netherlands

+31 (0)183 626 252  
www.amfbakery.com  
sales@amfbakery.com



Bakeries and food producing companies around the world partner with AMF Bakery Systems – inclusive of AMF Tromp and AMF Den Boer – for best-in-class unit equipment and complete system solutions, from mixer to marketplace. Through innovative, precision engineering informed by our master bakers' expertise, AMF designs integrated production solutions for soft bread and buns, artisan bread and rolls, pizza and flatbreads, cakes and pies, pastries and croissants, and beyond. Single units machines and complete lines, at market standard and sometimes tailor made is what we offer and market for many years. Den Boer is our oven building company, where we produce production ovens, tunnel ovens or band ovens for many food applications, like bread, cake, muffins, pizza, pie, pastry, crackers, rusk, cookies and many more. AMF Den Boer has introduced the world's first

Hydrogen fuelled tunnel oven, than can bake at 0,0% emission and thus improve the bakery footprint immediately. Our Hydrogen burners can be retro-fitted onto existing ovens, and also Hybrid models are available, where natural gas and Hydrogen are combined, to make a first sustainable step for bakeries, until prices of Hydrogen drop more. AMF Europe is part of a global company with facilities in the United States, Latin America, United Kingdom, the Netherlands, China, and Singapore, collaborating with more than 600 teammates worldwide. With a mix of global networking and local charm, the AMF Europe teams encompass a culture of passionate people who are committed to developing better food and better lives for their teammates, families, customers, and community.

**Ansaldo Thomassen B.V.**

Huub Koeman  
Havelandseweg 8D  
6991 GS Rheden  
The Netherlands

+31 (0)26 497 58 00  
www.thomassen.energy  
info@thomassen.energy

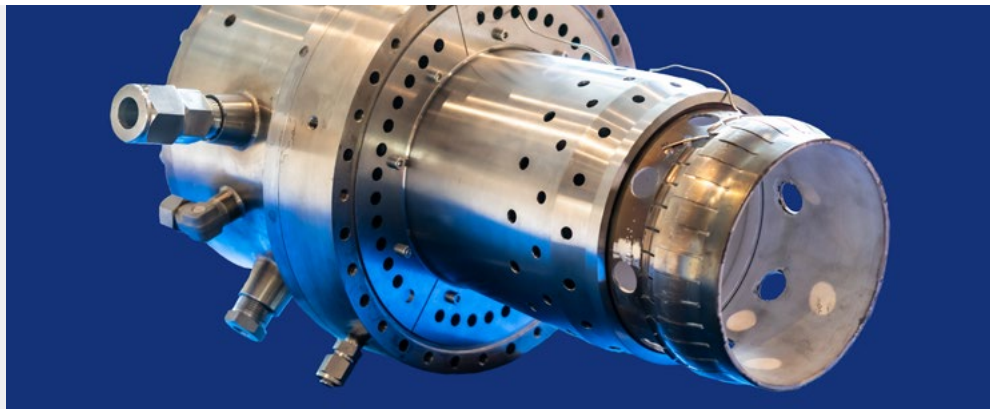

Ansaldo Thomassen (ATH) is a leading supplier of technologically advanced aftermarket gas turbine components, performance upgrades, in-house component repair and outage services for existing GE heavy-duty gas turbines. We offer flexible and comprehensive Service Agreements (FSA's), ranging from parts supply and reconditioning to full scope agreements including remote monitoring and diagnostics and inventory management.

Our vision is to supply cost effective advanced retrofit solutions for a Clean Energy World. ATH is leading a consortium targeting the demonstration of gas turbine retrofit technology for hydrogen. Together with our partners we are currently working on our High Hydrogen Retrofit Project.

Major objective of this project is to develop a cost-effective ultra-low emission (sub 9ppm NOx and CO) combustion system retrofit for existing installed gas turbines in the output range of 1 MW to 300 MW. At the centre of this innovative high-technology project is the patented and novel aerodynamic trapped vortex FlameSheet™ combustion technology platform. Fuel flexibility and stable operation from 100% natural gas to 100% hydrogen and any mixture thereof, is a key requirement.

**Antonius**

Ralph Giesen  
S. Houbenweg 1  
6051 AL Maasbracht  
The Netherlands

+31 (0)475 439 000  
www.antonius.nl  
rgiesen@antonius.nl



**ANTONIUS**

The energy transition is taken place right now and we are living it together. Green hydrogen will play a key role in regulating our energy needs based on supply and demand. Therefore the storage of renewable energy and the infrastructure is an important part of the whole process.

Antonius can be your industry partner for storage and transport design of energy. We are an experienced fabricator that can design your production process and build your newly developed product. Your idea will be transferred into a design ready for production. As your partner we will take care of the complete project management, fabrication and assembly of your product. Over 80 years of craftsmanship in shaping metals brought us to the level we are at right now.

With our extensive knowledge of materials and production methods, with the best qualified welders in the industry and our special machines we can produce high quality products against all applicable standards. Our craftsmanship is the reason why customers and engineering firms do contact Antonius at an early stage.

We have an ideal situated production location (40,000 m<sup>2</sup>) with a direct waterside connection, to transport big parts by ship worldwide.

Meet our strength and challenge us to experience our craftsmanship. Let's work together and make this green deal! ANTONIUS.

**AquaBattery B.V.**

Jiajun Cen  
Lijnbaan 3C  
2352 CK Leiderdorp  
The Netherlands

+31 (0)6 39 65 66 09  
aquabattery.nl  
jiajun.cen@aquabattery.nl



AquaBattery is a deep-tech company based in the Netherlands working to revolutionize green energy storage. Our mission is to cut energy bills and catalyse the development and uptake of renewable energy technologies across the EU and beyond. We recognize that renewable energy is only part of the solution, and only through pairing it with cheap and scalable energy storage solutions can truly make an impact. AquaBattery was founded in Leiden in 2014 to commercialize the world's cleanest energy storage solution: a battery that can store renewable energy in water and salt (such as seawater). Our team is composed of leading experts in water membrane technologies and the energy storage industry, combined with the leadership of visionary founder Dr. Jiajun Cen. Together, the team combines 50+ years of engineering experience with 25+ years in business and management.

We are supported by a network of exceptional partners, such as Climate-KIC, TU Delft, The Green Village Delft, and technical experts at Imperial College London, REDStack, and Wetsus. Our technology has been successfully demonstrated through several prominent installations in the Netherlands and in Italy and has reached TRL 6. Our saltwater battery is a flow battery where power and storage capacity are decoupled. The user can decide on how large the respective components of power or storage capacity need to be in order to suit the application. The cost for scaling up the storage capacity is low, one just need a larger tank, some salt and water. At locations where space is not the limiting factor, we can realise virtually unlimited storage capacities. This makes our battery very well suited for long-duration storage (10+ hrs).



## Arcadis

Marcus Rolloos / Moreno de Respini  
Piet Mondriaanlaan 26  
3812 GV Amersfoort  
The Netherlands

+31 (0) 6 53 16 18 77 / +31 (0)6 21 65 24 48  
www.arcadis.com  
marcus.rolloos@arcadis.com /  
moreno.derespinis@arcadis.com



### Arcadis: Energy transition & climate challenges in a rapidly changing world

Arcadis has an independent position in the market. Second, our company truly acts as a global player, active in 70 countries. Colleagues from different parts of the world are already working together to deliver the best solution for our clients, for example in Pecem, Brazil. With sustainability at the heart of everything we do, our focus is on maximizing our impact aimed at improving quality of life.

### Hydrogen & hydrogen carriers

Our main services:

- (pre)Feasibility studies & FID
- General Engineering
- Environmental & Social Impact Assessment (ESIA, CSR)
- Safety and hazard studies
- Licensing & Permitting

### Hy3+

Arcadis and TNO are now working on the Hy3+ program. We are building a dynamic gas model and with a PESTEL analysis, we will evaluate the security of supply, demand & storage for the largest industrial clusters in the world (BeNeLux & DE). In fact it is a stress test of the planned hydrogen network with all large hydrogen value chain players involved: mainly industries for production, import and offtake, but of course also grid operators, governments & ports (see picture). For more information please visit and reach out if you would like to join:

<https://hy3.eu/2023/12/22/hy3-has-kicked-off/>

## AVK Nederland B.V.

Dana Hofman  
Radeweg 12  
8171 MD Vaassen  
The Netherlands

+31 (0)578 574 490  
www.avknederland.nl  
info@avknederland.nl



AVK Nederland is part of the AVK Group, market leader in the field of appendages in the segments: water, gas, wastewater, fire protection and industry. Our range consists of a wide variety of valves, fire hydrants, couplings, street covers and accessories that all meet the highest standards in terms of safety, durability and quality. Every day, AVK solutions help deliver clean water and sustainable energy to millions of people in households and industries all over the world. We assist in transporting, treating and reutilizing wastewater, and in assuring safe, secure surroundings ready to battle unfortunate events of fire. We work towards a better, more sustainable future, where natural resources are used and managed wisely. We want to make our

performance on social responsibility concrete and objectively demonstrable by means of the CSR Performance Ladder certificate, level 4. AVK would like to contribute to a successful and safe energy transition. Hydrogen can become an important link in the energy supply of the future. It is a sustainable option as a raw material and energy carrier. Moreover, the infrastructure needed to transport and store it is already largely available in the Netherlands. With AVK gas valves you are ready for the future with our KIWA certification for hydrogen. AVK also contributes to projects testing hydrogen distribution. In the Netherlands gate valves are supplied to a project with TU Delft 'The Green Village' where 100% hydrogen is being tested.

**Avoxt B.V.**

Ton Rademaker  
HTC 27  
5656 AE Eindhoven  
The Netherlands

+31 (0)6 81 08 38 88  
www.avoxt.com  
info@avoxt.com



Avoxt is a pioneering company that specializes in the development of high-efficiency hydrogen electrolysis technology. Their innovative electrolysis systems use alkaline electrolysis technology to convert water into hydrogen and oxygen with exceptional efficiency.

The technology is highly efficient, making it a more cost-effective and sustainable solution for producing hydrogen.

Avoxt's electrolysis systems are modular, compact, and easy to integrate into existing energy systems. They can be used in a variety of applications, including energy storage, transportation, and industrial processes. Avoxt's systems are also highly flexible, allowing them to adjust to varying electricity inputs, making them

an ideal solution for balancing the grid and managing intermittent renewable energy sources.

Moreover, Avoxt is committed to sustainability and reducing carbon emissions. By providing a clean and efficient way to produce hydrogen, Avoxt is helping to reduce dependence on fossil fuels and promote a more sustainable future for generations to come.

Overall, Avoxt's hydrogen electrolysis systems offer a highly efficient, sustainable, and cost-effective solution for producing hydrogen using alkaline electrolysis technology. With their commitment to innovation and sustainability, Avoxt is well positioned to play a leading role in the transition towards a carbon-free future.

**AWL Techniek B.V**

Erwin Janssen  
Keplerstraat 5  
3846 CN Harderwijk  
The Netherlands

+31 (0)341 411 811  
www.awl.nl  
info@awl.nl



At AWL, we specialize in building scalable, modular, and flexible production lines tailored to your fuel cell and electrolyzer production needs. Our comprehensive range of services ensures seamless integration into your production processes, offering complete production lines, embeddable process modules, process automation, and pre-investment testing.

AWL boasts over 30 years of expertise as a leading machine builder and system integrator in the automotive, metal processing, and logistics sectors worldwide. Our commitment to delivering excellence lies in our ability to design and construct intelligent, modular machines that add significant value to your operations.

We excel in laser applications, quality control, traceability, and turn-key automated

manufacturing solutions. Our innovative approach and unwavering dedication to quality enable us to meet the industry's evolving demands while ensuring efficiency and reliability in every project we undertake.

For the H2 market we offer low volume production machines that can be scaled to high volume lines with the focus on cost reduction solutions for a variety of processes such as welding, gluing, sealing, cleaning and integration of other processes like coating and leak testing. Quality gating and part traceability are major aspects of these lines.



**BA2C**

Willem Frens  
Lange Poten 29  
2511 CM The Hague  
The Netherlands

+31 (0)6 48 35 32 63  
www.ba2c.com  
info@ba2c.com



BA2C Europe / Latin America (BA2C) is a green hydrogen and renewables chemicals/fuels/ electricity project developer. It is our aim to be (one of) the first project developers introducing new, but most efficient, technologies to produce green ammonia (NH<sub>3</sub>), methanol (CH<sub>3</sub>OH), synthetic fuels from renewable electricity, municipal and organic waste feedstock. In this way we decarbonize existing brownfield industrial production sites (to make use of the existing assets) or set-up greenfield plants in areas where renewable electricity, municipal and agricultural waste is cheap. BA2C cooperates in its projects together with leading technology developers from all over the World.

With our knowledge with energy transition and industrial transformation BA2C also advises

companies and ports to define best strategies to become energy efficient and reduce CO<sub>2</sub> emissions while keeping a good and interesting business case.

BA2C also invests in other green molecule development projects. Examples are the well-known Liquid Wind initiative (to produce renewable methanol from biogenic CO<sub>2</sub> and green hydrogen) and HyAPC, a venture of BA2C. This last Netherlands technology is an oxy-fuel combustion technology using green hydrogen and green oxygen (both from an electrolyser). In future we are convinced HyAPC will play an important role to balance the (renewable) electricity system. Another activity of BA2C is guiding and supporting scientists to develop new generation technologies.

**Battolyser B.V.**

Kathleen Dingenen  
Jan Evertsenweg 38  
3115 JA Schiedam  
The Netherlands

+31 (0)10 473 92 73  
www.battolysersystems.com  
info@battolysersystems.com



Battolyser Systems develops and manufactures the world's first electrolyser with an operating range of more than 100%: the Battolyser®.

That is because a Battolyser® is a battery and electrolyser in one unified system. The patented technology can store and supply electricity as a battery, but during loading and when it is fully charged, it automatically starts splitting water from the electrolyte into hydrogen and oxygen as an electrolyser.

Thanks to its ultimate flexibility which allows to follow any renewables load curve and an outstanding overall efficiency above 80%, we can deliver the lowest Levelised Cost of Hydrogen, while balancing the grid for societal demand.

Battolyser® only uses the abundantly available materials Nickel and Iron and is hence a suitable solution of large scale hydrogen projects.

Battolyser Systems is a Delft University of Technology spin off and has Koolen Industries as the main shareholder. It plans to build a production facility of 1GW nameplate capacity in partnership with Port of Rotterdam.

Commercial demonstration units of 1-5MW are to be delivered in 2024, followed by large scale commercial series production in 2025 onwards for global roll-out.

### Berenschot

Bert den Ouden  
Van Deventerlaan 31-51  
3528 AG Utrecht  
The Netherlands

+31 (0)6 51 99 42 86  
www.berenschot.nl  
b.denouden@berenschot.nl



## Berenschot

We work with Dutch and European organizations in the energy sector, users, industries and governments to conduct system studies, roadmaps, strategic- and policy advice. Our services related to hydrogen are embedded in a systemic view:

**Scenario studies:** we provide insight into the consequences of choices with regard to our energy system, both economically and energetically. Recently, we developed four national scenarios for a low carbon future in 2050 (II3050). In all scenarios hydrogen (green & blue) plays a pivotal role in system balancing, storage and decarbonisation of sectors.

**Flexibility and system integration:** we provide support in quantifying the potential and feasibility of flexibility measures like power-2-gas and

hydrogen storage. Currently, we are developing a blueprint for a Hydrogen Exchange in the Netherlands. We analyse the technical, energetic and economic consequences of flexibility measures in the short and long run. We often work together with the energy industry.

**Techno-economic analysis:** we help to translate ambitions into plans for technology options like heat pumps, heat networks or carriers like hydrogen in order to arrive at the best future-proof solution with low costs and high durability.

**Implementation of the strategy:** we have extensive experience with organizations that operate in a mix of a regulated playing field of government and business. We help you with your strategy, design of the organization and the optimization of business processes.

### Bilfinger Engineering

Arjen Teunissen  
Laan van Nieuw Oost-Indië 25  
2593 BJ The Hague  
The Netherlands

+31 (0)88 996 70 00  
www.bilfinger.com  
communication.bene@bilfinger.com

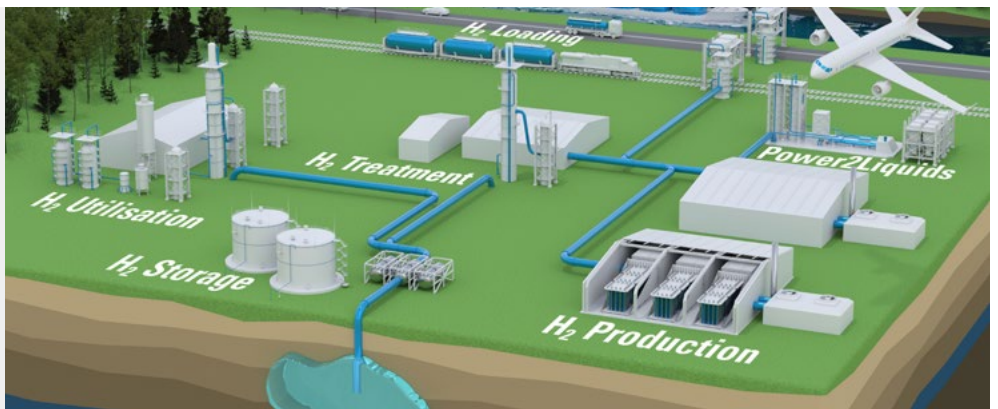

## BILFINGER

As part of the Bilfinger Group, Bilfinger Engineering can call on a strong global network with a broad spectrum of expertise. This gives us the opportunity to proactively anticipate our customers' needs with the best integrated services. Our comprehensive hydrogen solutions offer industrial companies consulting and implementation services ranging from production to storage, transport and application.

Our services for the hydrogen market include:

- **Consultancy and engineering:** Bilfinger supports and advises plant operators, energy suppliers and users of hydrogen from the very first step. The range of services extends from feasibility studies to conceptual and basic engineering.
- **Plant construction and EPC services:** Bilfinger offers a full range of plant construction

services including project management, detailed planning and control, procurement and the execution of construction and installation work.

- **Maintenance and service:** Bilfinger is a reliable and experienced partner when it comes to operating, maintaining and optimizing plants and can provide all maintenance and service activities.
- **Technologies:** Bilfinger employees have unique process expertise and are familiar with a wide range of technologies and processes for the production, transport, storage and utilization of hydrogen. They can also evaluate the effectiveness and efficiency of components and processes.



**Bosal**  
Ted Straten  
Kamerlingh Onnesweg 5  
4131 PK, Vianen  
The Netherlands

www.bosal.com  
info@bosal.com

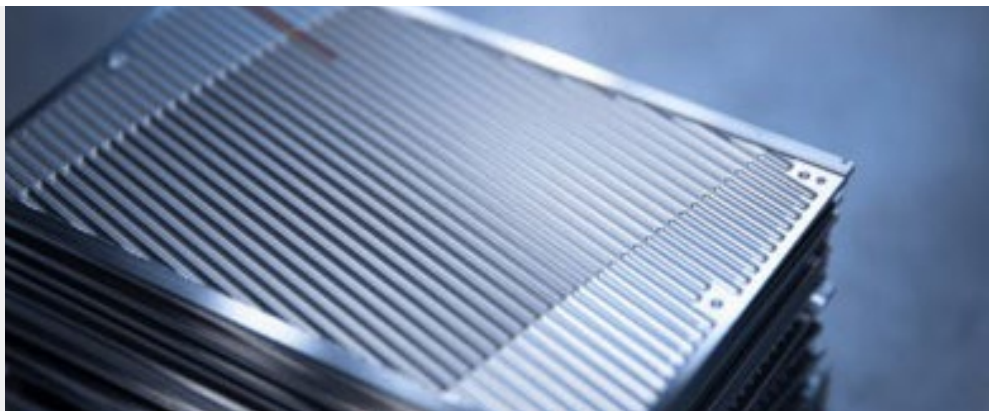

BOSAL is a family-owned company founded in 1923 in the Netherlands.

With more than twenty-five years' experience in the energy sector, BOSAL is determined to take a leading position in the emerging hydrogen market. We provide proven solutions for numerous hydrogen related technologies which have an important role in the near future, such as Solid Oxide Fuel Cell Technology (SOFC) and Solid Oxide Electrolysers (SOEC).

BOSAL's main competitive differentiator is our offering of our ultra-thin foil high temperature heat exchangers integrated in a hot balance of plant, which combine highest effectiveness with low back pressure in very compact designs.

To increase the level of integration, BOSAL's heat exchangers can be supplemented with a number of value-adding features as: integrated catalytic oxidative and reductive coatings, protective coatings, integrated mixers, insulation and piping.

To offer its customers tailor-made solutions, BOSAL formed successful engineering and research partnerships with several leading industry players.

We have more than 1,700 employees supporting our mission in 16 manufacturing plants and distribution centers and 6 R&D sites worldwide.

**Bosch Rexroth B.V.**  
Patrick Hendriks  
Kruisbroeksestraat 1  
5281 RV Boxtel  
The Netherlands

+31 (0)411 651 295  
www.boschrexroth.nl  
sales@boschrexroth.nl



**rexroth**  
A Bosch Company

Green hydraulics: basis for efficient H<sub>2</sub> supply. The political framework is in place. Now it is important to find the right technologies for the rapid introduction of green hydrogen. Hydraulics is one of them, as it can compress hydrogen highly efficiently and safely. Last but not least, filling stations are thus particularly reliable and energy efficient.

Proven industrial hydraulics solutions are a major help in building the H<sub>2</sub> infrastructure. With Bosch Rexroth as a partner, the players benefit from needs-based support. This ranges from robust and safe components to engineering support and complete solutions.

When setting up H<sub>2</sub> filling stations, manufacturers and operators can choose from several approaches: For H<sub>2</sub> compression up to 900 bar and a delivery rate of approx. 100 kg/h, either highly dynamic cryogenic pumps or highly efficient compressors with linear or rotary drives can be considered. If smaller delivery rates are required, servo-hydraulic compact axes generate advantages because they require little space, especially for retrofitting in urban areas, and can be put into operation quickly thanks to the Plug & Produce preconfiguration.

Safety shut-off blocks and valves from Bosch Rexroth also prove their worth when transporting H<sub>2</sub> in pipelines. In addition, the hydraulics expert's close-knit service network creates the best conditions for optimum on-site maintenance.

### Bosch Thin Metal Technologies

Caro Roeffen  
Dr. Hub van Doorneweg 120  
5026 RA Tilburg  
The Netherlands

013 464 0333  
<https://www.bosch-hydrogen-energy.com/>  
ThinMetal.Technologies@nl.bosch.com

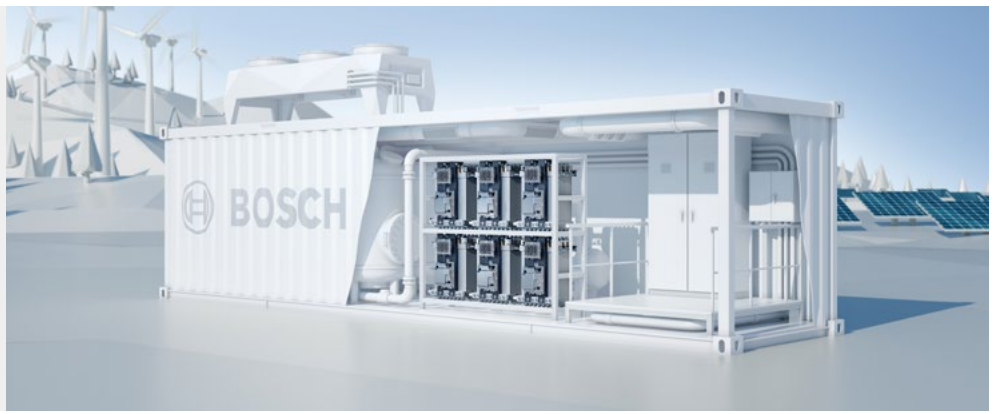

Our many years of experience and competencies in the production of high-precision automotive stamping parts are now being used for the development and production of systems and thin metal components for electromobility, fuel cells and hydrogen technology. Bosch Tilburg is the R&D pre-development center within the BOSCH GROUP for the development of electrolyzer stacks. Customers can contact Bosch for PEM stacks of 1.25 MW.

The location also supports the production development of bipolar plates for electrolyzers and fuel cells. Bipolar plates are a crucial component for the construction of electrolyzer and fuel cell stacks.

### Bredenoord

Franz Hullegie  
Zutphensestraat 319  
7325 WT Apeldoorn  
The Netherlands

+31 (0)55 301 85 01  
[www.bredenoord.com](http://www.bredenoord.com)  
[info@bredenoord.com](mailto:info@bredenoord.com)



Bredenoord is an independent family-run business that develops, supplies, maintains and operates the most reliable and cutting-edge decentralized energy systems worldwide and, consequently, provides its customers with energy security. Bredenoord continuously works on developing the energy solutions of the future and is one of the initiators in developing hydrogen applications in mobile and temporary energy, with a focus on sustainability, low emission and safe operation. Development of the first hydrogen genset started as early as 2006 and resulted in the Purity in 2009, which has powered various events, among other projects. With over ten years of experience with the Purity, Bredenoord continues the development of a hydrogen genset and takes part in various demos and pilots.

Through a clever combination of fuel cells and battery packs the Purity can be used straight away for projects with a low power demand. Bredenoord keeps aiming for innovative use of hydrogen technology for mobile power installations and, for example, also researches the use of hydrogen in combustion engines for gensets. These various research projects take place in collaboration with a variety of partners. Bredenoord is always open for new collaborations in this field.



## Brigh2

Marc van Doorn  
Urmonderbaan 22  
6167 RD Sittard - Geleen  
The Netherlands

+31 (0)6 10 90 75 83  
www.brigh2.com  
marc.vandoorn@brightlands.com

## Torrefaction and gasification

Innovative and scalable technology that produces a sustainable synthetic gas

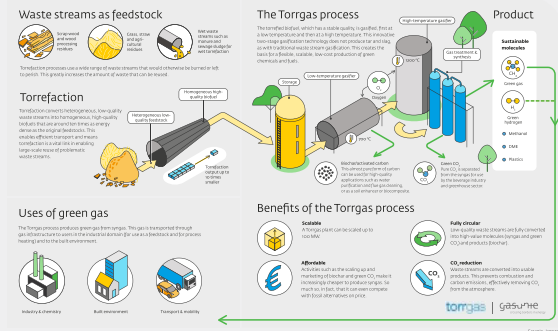

Brigh2 : The Renewable Alternative. Brigh2 plans to start a 50 MW gasification unit to produce 6300 mtpa renewable hydrogen, pure bioCO<sub>2</sub> and Biochar. The Demonstration plant will be situated on Brightlands Chemelot Campus and will serve the industrial users on the Chemelot site, but also intends to produce Fuel Cell grade Hydrogen for the mobility sector. The project is in the feasibility phase at the moment. The location of the plant on the Chemelot campus fits exactly with the circularity target of the campus and the site. The feedstock will be torrefied biomass, where torrefaction does create a significant extension of the area where the biomass is gathered. Torrefaction also creates an uniform feedstock for the delicate process, reducing the investment costs per ton of renewable hydrogen to the max, but has proven

itself in the quality of the syngas produced and the potential for uninterrupted continuous production. Next to the hydrogen production, Brigh2 also provides a long term sustainable route for CCU processes due to the biogenic origin of the CO<sub>2</sub> produced, as well as negative CO<sub>2</sub> emissions by connecting to the CCS infrastructure under development on the Chemelot site. Alternatively the CO<sub>2</sub> prevents an additional fossil CO<sub>2</sub> emission once applied in greenhouses. The Biochar is of exceptional quality and suitable for a large number of applications now dependent on petrochemical coke of low sulfur. The technology is developed in Groningen on a 1 MW scale and is further scaled towards a 2 x 12.5 MW unit to produce Methane from syngas in Delfzijl.

## Bronkhorst Nederland B.V.

Ger Jan Dorland  
Lunet 10c  
3905 NW Veenendaal  
The Netherlands

+31 (0)318 551 280  
www.bronkhorst.nl  
info@bronkhorst.nl



Bronkhorst is leader in low flow fluidics handling technology. The small robust flowmeters of Bronkhorst are very well suitable for testing fuel cells and electrolysers, both for research and production applications. Our instruments are ideally suited for delicate control of the pressure or flow of single gases, liquids or fluidic mixes to support development and quality issues. We also support improvements to LOHC (liquid organic hydrogen carrier) and hybrid hydrogen carrier technology. The IN-FLOW range of instruments can be applied to measure high quantities of hydrogen at production sites. Because we offer low flow liquid flow control technology as well, our instruments are used in odorant delivery to hydrogen or natural gas that are injected in gas grids.

Bronkhorst offers an extensive product range of thermal, Coriolis and ultrasonic flow meters and flow controllers for low flow rates of gases and liquids. Its flow instruments are used for a variety of applications in laboratory, machinery, industrial and hazardous areas. By sharing their knowledge and closely cooperating with OEM customers and research organisation in the field, Bronkhorst develops customer specific low flow solutions, e.g. of multifunctional, pretested modules or skids for gas, liquid or vapor flow control.

Bronkhorst is a truly world-wide organisation with an extensive network of distributors and service stations across Europe, the Americas, Africa, the Middle East, Asia Pacific in Japan.

**Brunel**

Huub Sturkenboom  
John M. Keynesplein 33  
1066 EP Amsterdam  
The Netherlands

+31 (0)6 3023 1809  
www.brunel.net  
h.sturkenboom@brunel.net



# Brunel

Founded in 1975, we are a global specialist delivering customised project and workforce solutions to drive sustainable industry transformations through technology and talent.

With 120+ offices and a powerful network of more than 12,000 specialists around the world in 45 countries, we deliver Project and Consulting Solutions, Workforce Solutions and Global Mobility Solutions that transform global projects in Hydrogen, Renewables, Conventional Energy, Mining, Life Sciences and many other sectors.

You are committed to delivering projects that meet the highest quality standards with full legal compliance. But how do you do that safely, on time and on budget, every time? Brunel provides the custom support, international network and

local knowledge that your projects need to thrive.

Do you sometimes struggle to improve productivity and achieve organisational goals while also optimising your workforce management? Brunel leverages advanced recruitment techniques and strategic workforce planning to streamline talent acquisition and enhance your overall performance.

Have you ever tried to master the complexities of international workforce mobility while solving the logistical nightmare of getting your teams to ten different places? Brunel seamlessly transfers individuals, teams and even whole businesses wherever they are needed – from the next state or region to the farthest corners of the planet.

**Bureau Veritas**

Roman Latsuzbaia / Pim Reuderink  
Plotterweg 38  
3821 BB Amersfoort  
The Netherlands

+ 31 (0) 88 450 5750  
benelux.bureauveritas.com/hydrogen  
technicalsafty@bureauveritas.com



Bureau Veritas is a world leader in laboratory testing, inspection and certification services. Created in 1828, the Group has more than 83,000 employees located in more than 1,600 offices and laboratories around the globe.

Bureau Veritas helps its clients improve their performance by offering services and innovative solutions in order to ensure that their assets, products, infrastructure and processes meet standards and regulations in terms of quality, health and safety, environmental protection and social responsibility.

With a rich history of bringing trust, transparency, and quality assurance to clients, and as a Hydrogen Council member since 2020, Bureau Veritas has the expertise to support hydrogen industry players today and tomorrow. Leveraging

our well-established position within the oil and gas, power and utilities, and shipping industries, Bureau Veritas is a strategic partner to hydrogen energy players worldwide. We bring our global, broad and cross-sector technical expertise in the field of hydrogen to the industry.



### Bürkert Fluid control systems

Jasper Luik  
Minervum 7220  
4817 ZJ Breda  
The Netherlands

+31 (0)6 22 39 34 35  
www.burkert.nl  
jasper.luik@burkert.nl



Bürkert Fluid Control Systems is one of the world's leading manufacturers of measuring, control and regulating systems for liquids and gases. Bürkert products are used in a wide range of industries and applications, ranging from labs to medical, bio-engineering and aerospace technology. With a portfolio of more than 30,000 products, Bürkert is the only supplier to offer all fluid control system components, from solenoid valves to process and analytical valves, from pneumatic actuators to sensors.

With its headquarters in Ingelfingen in Germany, the company has a wide-ranging sales network in 36 countries and more than 3,000 employees. Bürkert develops customized solutions and innovative products at its five Systemhaus locations in Germany, China, and the USA. The product portfolio is topped off by extensive services, from consulting and conception, through

implementation, to maintenance and training. A rule of thumb applies in the language of engineers: the quality of a system is proportional to the quality of its components. In fact, the peripherals are coming more to the fore among experts – with control and regulating system modules as well as intelligent process related coupling of these components. This is where Bürkert has been active for over 60 years. As one of the few providers who can cover the entire process chain involving measuring, controlling and regulation.

It is no wonder, that the Bürkert product range includes precisely those components which are optimal for use in hydrogen technology: certified modules with low power consumption, a wide temperature range, chemically resistant properties and a good price-performance ratio.

### Stichting Cenex Nederland (Cenex NL)

Theodora Skordili  
Overhoeksplein 2  
1031 KS Amsterdam  
The Netherlands

+31 (0)20 369 98 83  
www.cenexgroup.nl  
hello@cenexgroup.nl  
theodora.skordili@cenexgroup.nl



Cenex NL is an independent not for profit research and consultancy organisation on zero emission mobility and related infrastructure, and the circular economy with regards to mobility.

Cenex NL is not driven by shareholders or returns-on-investment and was founded in 2018 for the purpose of accelerating transition to clean transport by providing technical expertise and disseminating lessons learned across Europe.

Cenex NL is a strategic partner of the UK's first Centre of Excellence for Low Carbon and Fuel Cell Technologies (Cenex UK – est. 2005). The Cenex organisations are established players in the European hydrogen community through:

- Active on-going participation in European R&D work:
  - H2ME (2016-2022): EU's largest FCEVs and refuelling infrastructure demo;

- ZEFER (2017-2022): Commercial and operational viability of high-usage vehicles;
- HyTrec2 (2014-2020): Hydrogen vans, trucks and refuse collection vehicles in North Sea Region.

- Market studies that analyse the European hydrogen market, enabling conditions and policy landscapes for technology take-up.

We offer expertise to automotive industry, early adopters of FCEVs and policy makers looking to implement strategies to accelerate the use of clean hydrogen in mobility. Examples include:

- Performance analysis of vehicle and refuelling infrastructure at real-world operations;
- Customer value proposition and business case of hydrogen in land transportation;
- Life Cycle Analysis of FCEVs and refuelling infrastructure.

**Circonica Circular Energy BV**

WJH (Hans) Gerritsen  
Robert Boyleweg 4  
2333CG Leiden  
The Netherlands

+31 (0)6 1133 2727  
www.circonica.com  
info@circonica.com



In a world that strives for CO2 neutrality, Circonica is developing a component that can help the Netherlands lead the way in the energy transition. At the heart of this initiative is the Hollow Electrode Loose Stacking Solid-Oxide Fuel Cell (HELP-SOFC), a groundbreaking fuel cell technology from Circonica. This technology promises to revolutionize cost, energy efficiency, and reliability, while reducing CO2 emissions by 70-100%.

The existing proof-of-concept of the HELP-SOFC is unique in its kind due to its versatility in fuel use, from fossil fuels to biofuels and hydrogen, allowing it to perform optimally and achieve impact during all phases of the energy transition. In addition, the system can act as a fuel cell and/or electrolyser for hydrogen production, making it particularly

suitable for many applications.

Together with its partners within projects such as TSE (completed), GTD-H (ongoing) and the NGF-4 application for rSOC-NL with, among others, VDL, Bosal, TNO, RUG and 12 others, Circonica strives to achieve a cost breakthrough for mass production of SOFC/SO2E with the HELP concept. First in stationary applications (built environment), such as powering cable networks and micro-CHP systems. Then in markets for hydrogen mobility and electrolysis. To this end, Circonica search to link up with partners with knowledge, infrastructure, maritime and petrochemical activities, but especially ambitions in the field of hydrogen and its applications.

**CLEAR**

Willem-Jeroen Stevens  
Jachthavenweg 109  
1081 KM Amsterdam  
The Netherlands

+31 (0)5029 5914  
www.clearcf.com  
wjs@clearcf.com



CLEAR is a financial advisory boutique with an international team, assisting deep tech, climate tech and clean tech scale ups in raising growth capital as well as providing financing solutions for renewable projects. Headquartered in Amsterdam though compiled of a group of 20+ internationally based entrepreneurial partners, each with their unique background and network across sectors such as technology, advisory, manufacturing and investment, CLEAR understands the complexities, rewards and hurdles involved in growing a business and securing funding. The CLEAR team provides expert financial advisory services and finds the right investor for technology companies on a global scale.



### Cohesys

M.H.F. van Woensel  
Dempseystraat 14  
5453 JR Langenboom  
The Netherlands

+31 (0)6 54 70 02 12  
www.cohesys.nl  
marc@cohesys.nl

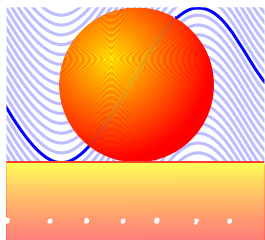

Cohesys is a consulting company on metallurgical and/or production related issues. With more than 30 years of working experience we have done many projects in high (and low) tech environments. Our projects include setup for laboratory scale production up till mass production. We are busy in semiconductor production and the nuclear industry, but find ourselves equally at home in a foundry.

We excel in fast and reliable literature search and advice and train your people in metal and hydrogen related questions. We understand production in all stages, from drawing board till mass fabrication. If you don't know how to start or how to scale your production process up to the next level: call us.

### Connectr - Energy innovation

Jeroen Herremans  
Westervoortsedijk 73  
6827 AV Arnhem  
The Netherlands

+31 (0)85 483 09 88  
www.connectr.nu  
info@connectr.nu



Connectr, where new energy innovations emerge and grow. The Province of Gelderland has a strong energy cluster centred in Arnhem, where Connectr is located. Arnhem is known as the Hydrogen Tech capital of The Netherlands due to the concentration of SME companies in the value chain of high tech hydrogen solutions. By ensuring the vitality and growth of that cluster, Connectr contributes to the energy transition, the regional economy, and the human capital agenda. The strength lies on the implementation level: new ideas are immediately tested and put into practice from Connectr, and they can grow from there. Connectr is a triple-helix foundation funded by public and private parties as well as knowledge institutions. Partners are the city of Arnhem, The Province of Gelderland, HAN University of Applied Sciences including SEECE and ACE, Development

companies as OostNL and KiEMT, IPKW, Generation E and many energy related companies resident in Connectr or the region or actively connected with projects.

Connectr consists of an Innovation Program, an Innovation Lab and Shared Facilities. In the midst of these components, the Core Organization provides connection, reinforcement, and acceleration.

Focus strengthens the contribution to the global energy transition. That's why Connectr focuses on three key technologies that are already developing strongly in the region and that will add value on an international level.

1. Power systems engineering
2. Electrochemical energy storage
3. Sustainable drive systems

### ConPackSys B.V.

Wout Roovers  
Burgemeester De Raadsingel 61  
3311 JG Dordrecht  
The Netherlands

+31 (0)78 6391 114  
www.conpacksys.nl  
sales@conpacksys.nl  
Wout.Roovers@ConPackSys.nl



ConPackSys is an engineering firm located in Dordrecht, the Netherlands close to the Rotterdam and Antwerp harbours. We specialize in the engineering, packaging, construction and commissioning of compressor systems for the industry. This entails the technical design, fabrication and testing of the compressor itself but also its auxiliary systems; drivers, process equipment (coolers, separators), piping, control and instrumentation, noise enclosures and lube oil systems. These are all required for safe and sound operation of the compressor. ConPackSys has experience with applications for hydrogen and carbon dioxide (including Carbon Capture and Storage).

Compression is going to be important throughout the hydrogen value chain. Compression is required for storage of hydrogen, for transportation from A to B and also at the end-user. Hydrogen can be converted to green chemicals, to generate electricity or is used in mobility. ConPackSys is able to provide solutions for each of these applications with compressor duties ranging from 10 kW up to 10 MW. We specialize in tailor made and turn key systems for our clients.

### Corre Energy Storage

Arnold Frinks  
Paterswoldseweg 806  
9728 BM Groningen  
The Netherlands

+31 (0)50 790 10 00  
www.correenergystorage.nl  
info@corre.energy



Corre Energy Storage is a Dutch, Groningen headquartered business, that develops large scale renewable energy storage. The technique we use is called Compressed Air Energy Storage (CAES). We aim to develop several projects across Northern Europe, enabling the integration of renewables at large-scale and catalysing the energy transition and the Green Hydrogen Economy. Corre Energy wants to develop its first CAES project in Zuidwending, the Netherlands through its subsidiary Corre Energy Storage. CAES provides an energy balancing solution for both TSO's and renewable energy portfolio operators, without which countries like the Netherlands will be unable to reach the targets of 70% renewable energy by 2030.

Why this project? In order to guarantee a sustainable future – also for future generations – CO<sub>2</sub> emissions in the Netherlands (in Europe and

throughout the world) will have to be reduced drastically. In accordance with the Paris Climate Agreement, as society we produce more solar and wind energy every year. However, this growth also has its limitations. For example, the wind and the sun cannot be influenced, which means that sometimes too much and sometimes too little green electrical energy is produced. On days when more energy is produced than the market needs, installations sometimes have to be switched off, causing the loss of valuable energy and investments. On days when too little green energy is produced, natural gas has to be used and CO<sub>2</sub> is released. In short: it is very difficult for society to accurately absorb fluctuations in the electricity network without wasting energy or emitting CO<sub>2</sub>. The Corre Energy Storage project in Zuidwending offers the solution for these problems.



**Cryoworld B.V.**

Gerhard Knol  
Havenweg 11C  
1771 RW Wieringerwerf  
The Netherlands

+31 (0) 228 743 930  
+31 (0) 6 1555 4168  
www.cryoworld.com  
info@cryoworld.com

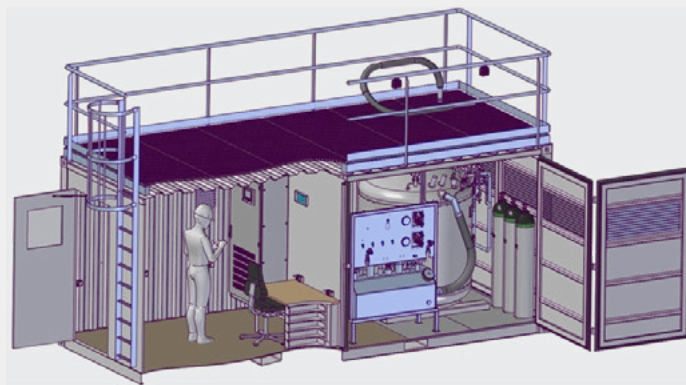

Cryoworld B.V. is a development company specialized in high-tech cryogenics in general. In recent years we have used our decades of experience for applications in Liquid Hydrogen. Through our in-depth cryogenic knowledge and experience in building advanced cryogenic installations for (scientific) applications (LHe, LAr, LH2, LiN, LOx) we have experienced that we can offer excellent and efficient designs and build solutions for LH2 applications. Our experience goes back many years. We have built for example the LH2 infrastructure for the Tokio Olympic games, and delivered in 2015 our first equipment, and rocket test benches for liquid hydrogen and oxygen.

We are particularly proud that major international operating gas suppliers, with their own in depth knowledge of liquid hydrogen, use us to build and/or design parts of their important LH2 products and systems.

Some relevant projects in LH2 in recent years :

- We have designed and manufactured the world's first refueling units for LH2 for mobility

applications, and our designs for tanks have the best gravimetric indexes in the world.

- We designed and delivered the first testing infrastructure for LH2 to TNO and NLR.
- We designed and delivered several distribution systems (with flexibles and rigid piping).

We can deliver the following products as a standard or bespoke item:

- Flexible metallic LH2 transfer-hoses with couplings, low heat load, self-closing
- Transfer units
- Storage dewars with low boil of rates, depending on demand and size
- Lab scale liquefiers
- Pump systems
- LH2 bayonet couplings, DN10 to DN40, in straight or 90° version, with optional filters, pressure relieve valve and/or non-return valves

Next to this we develop new systems in close cooperation with some customers.

**Danfoss B.V.**

Thor Eriksen / Ruud Versluis  
Fascinatio Boulevard 284  
3065 WB Rotterdam  
The Netherlands

+31 (0)6 39 805 342  
www.danfoss.nl  
thor.eriksen@danfoss.com /  
ruud.versluis@danfoss.com



**ENGINEERING  
TOMORROW**

With more than 90 years in energy efficiency, Danfoss offers a uniquely extensive range of cutting-edge solutions for green hydrogen, all the way from the grid connection to the electrolysis plant to hydrogen transportation and storage.

Our portfolio encompasses:

- AC to DC power converters: Our grid-friendly power supply solutions with impressive energy efficiency offers low harmonics and a high power factor, ensuring a competitive, scalable and stable power supply for electrolysis plants.
- High-Pressure Pumps and Energy Recovery Devices: Crafted to infuse ultra-pure water into the electrolysis cell, these pumps are engineered to achieve the elevated pressures vital for prolific hydrogen production.
- Water Treatment Solutions: Committed to

the perpetual provision of ultra-pure water for hydrogen generation, Danfoss delivers state-of-the-art solutions to transform seawater into deionized (DI) water via reverse osmosis.

- Heat Exchangers: Designed to facilitate the effective and consistent transfer of heat within the electrolyzer environment.
- Sensing Solutions: Precision-engineered sensors adept at measuring and relaying critical pressure and temperature data, essential for electrolyzer monitoring.
- Fluid Conveyance Solutions: With wide operating pressure ranges and optimal levels of abrasion resistance, our fluid conveyance components optimize solutions for cooling and conveying hydrogen.

Embark on the path to efficient hydrogen (H2) production with Danfoss as your guide.

**De Boer SPS**

A.H. de Boer  
Norgeweg 42  
8433 LN Haulerwijk  
The Netherlands

+31 (0)6 30 54 48 86  
www.deboer-sps.nl  
info@deboer-sps.nl



De Boer SPS is founded in 2008 and is an independent company specialised in development of new sustainable energy techniques and business. Examples are projects related to (bio) LNG, production of bio gas, bio methanol, energy from waste concepts etc.

De Boer SPS has developed logistical solutions for the storage and transport of gasses including hydrogen for several customers. New techniques like LOHC and liquid hydrogen where considered and further developed for upscaling and use. Furthermore, De Boer SPS has developed several concepts for (bio) LNG distribution and storage and can be also used for hydrogen distribution concepts.

Secondly, De Boer SPS is involved in new

techniques for capture and re-use of CO<sub>2</sub>. During the capture of CO<sub>2</sub> also H<sub>2</sub> is produced and with additional (green) hydrogen, this is the basis for several base chemicals and fuels like methanol, ethanol and urea.

Every project and initiative is unique and the approach of De Boer SPS is unique for every project. Please contact us for further acquaintance is our mutual approach will work for your company.

**Deelrijk | hydrogen & experts**

Helmer Buiteveld  
Pier Panderstraat 10  
8913CH Leeuwarden  
The Netherlands

+31 (0)582152619  
www.deelrijk.nl  
helmer.buiteveld@deelrijk.nl



Deelrijk is an independent project advisory firm focused on hydrogen. We initiate, guide, and realize hydrogen projects. We also temporary outplace experts that realize other energy transition projects. Deelrijk stands for sharing knowledge and enriching each other by collaboratively working on solutions, within and outside our organization.

Together with our partners, we develop and realize green hydrogen production sites, hydrogen storage and transport systems, and are involved in the development of hydrogen refueling stations (HRS). We believe that converting sustainable energy into transportable high-

quality gas is an important way to contribute to the energy transition.

The experts we temporary outplace contribute to the realization of a broader range of sustainable energy projects. We do this in the area of hydrogen, but also in wind energy, district heating networks, solar energy, and infrastructure. We primarily outplace experts on roles in the project development phase.



## Deerns

Frank Houben  
Anna van Buerenplein 21F  
2595 DA Den Haag  
The Netherlands

+31 (0)88 374 0000  
www.deerns.com  
frank.houben@deerns.com



As an independent engineering firm, Deerns specializes in advice, design and implementation supervision in the field of installation technology, building physics, energy supply and sustainability. Our expertise contributes to sustainable, intelligent and future-proof buildings that do what they are intended to do.

Our experts know the challenges our clients face. In the markets in which we operate, especially clean technology, data centers, healthcare, airports and real estate, we know what is going on and what is needed to arrive at a successful solution. We are able to provide suitable advice and design quickly, can provide construction supervision of installations and provide aftercare. So that eventually buildings are created that work for people.

Active in the following themes:

- Advice (Technology/Policy/Subsidies/Permits)
- Project Management
- Technique: Production (Electrolysis/etc.)
- Technology: Distribution (Pipework/ Appendages/Gas station/etc.)
- Technique: Storage (Bottle/Tank/Trailer/etc.)
- Technique: Use (Fuel Cell/Industry/Mobility/ etc.)
- Technique: O&M (Maintenance/Management/ Measurement)

## Deltalinqs

Diederik Kuipers  
Waalhaven Z.z. 19  
3089 JH Rotterdam  
The Netherlands

+31 (0)10 402 03 99  
www.deltalinqs.nl/  
deltalinqs-climate-program  
info@deltalinqs.nl



Within the Deltalinqs Climate Program (DCP) we work together on the climate transition of the Rotterdam Port Industrial Complex. In the DCP, Deltalinqs works with its members and partners on three themes: future energy mix, sustainable fuels & energy carriers and circular harbor & industry.

The role of the DCP is to connect the right parties to each other, to provide those parties with information and inspiration, and to help our members start innovative projects.

This includes projects across the full hydrogen value chain, including import as well as blue and green hydrogen, infrastructure, and industrial applications in hard-to-abate industries, as well as transport.

In the 'Versnellingshuis' we work together with public partners to mitigate barriers which are inevitable when starting new and innovative projects. Through our involvement in the Data Safe House, we help our infrastructure partners prepare the grid of the future.

**Demaco Holland B.V.**

Ronald Dekker  
Oester 2  
1723 HW Noord-Scharwoude  
The Netherlands

+31 (0)226 332 100  
www.demaco-cryogenics.com  
info@demaco.nl



Demaco is an expert in the field of cryogenic technology, we build infrastructures to facilitate the transport and application of industrial gases at extremely low temperatures. Between -160 and -271 degrees Centigrade, to be precise. We work with some of the most recognized companies and institutes around the world.

Demaco has worked in the hydrogen industry for over three decades. All projects are executed respecting all engineering and design standards for equipment for potentially explosive atmospheres (ATEX). It is applied to all types of electrical or non-electrical apparatus and as well as safety devices, ensuring reliability.

When it comes to hydrogen cryogenic equipment, Demaco is a turn key supplier, we assume overall responsibility and support customers around the world as a solution provider through the complete journey, starting from the idea to the

commissioning of the equipment. Demaco provides the design, manufacture, installation of cryogenic equipment including control system. Demaco serves the hydrogen market with the following products:

- Hydrogen filling stations or loading bays for filling trucks
- Hydrogen loading arms for refueling ships
- Hydrogen transfer lines from the tank or liquefier to the application either on-shore or off-shore
- Hydrogen cryostats
- Hydrogen distribution boxes
- Hydrogen purifier
- Hydrogen liquefiers (small/compact)

Since Demaco works on both standard and highly advanced projects, we have built up a vast experience. Consequently, no cryogenic issue is too ambitious.

**Demcon**

Jan Leideman / Mr Barend Vermeulen  
Institutenweg 25  
7521 PH Enschede  
The Netherlands

+31 (0)88 115 20 00  
www.demcon.com  
info@demcon.com



Demcon energy systems develops advanced technical solutions and provide innovative products in the field of sustainable energy. It draws on the extensive multi-disciplinary engineering know-how and production expertise that Demcon has built since 1993 for a very wide range of applications and technologies. The fast-growing Demcon group of companies currently employs 750 people in its branches in Best, Delft, Enschede, Groningen, Maastricht, Münster (Germany), Tokyo and Singapore.

One of the focus areas of Demcon energy systems is the development of technologies and equipment for the production of green hydrogen by means of water electrolysis. Together with partners, Demcon develops and supplies electrolyser modules for the decentralised

production of hydrogen for transportation and industrial applications, and other systems related to energy production and storage.

In addition to supplying complete systems, Demcon offers engineering and OEM production services to support our customers with the development and manufacture of their own solutions. Areas of expertise include mechatronics system engineering, multiphysics modelling, electronics and software development and industrial automation. Our customers can thus benefit from the unique combination of the very broad engineering excellence within the Demcon group and the deep understanding of the technical challenges in the sustainable energy sector that is the specialty of Demcon energy systems.



**Desu Systems B.V.**

Mark Nater  
Weg en Bos 20  
2661 DH Bergschenhoek  
The Netherlands

+31 (0)10 461 03 33  
www.desusystems.com  
mark@desusystems.com



Special Hazard Fire Detection & Suppression

Desu Systems strives to make hydrogen production, storage and the fuelling process as safe as possible. Being the European Master distributor for Spectrex flame detectors, we supply to OEM's, contractors and fire safety companies.

We have several flame detectors in our portfolio that can detect an (invisible to the human eye) hydrogen flame within (milli)seconds. Our products are known for their long life and fault-free operation.

Our Hydrogen flame detectors are already in use in many hydrogen filling stations, hydrogen powered vehicles, equipment and in storage facilities all over the world.

With our skilled staff and local stock we strive to provide fast and friendly service. Is your hydrogen project safe? Just give us a call.

**DLS – Drive Line Systems**

Rob van Gils  
Robijn 910  
3316 KE, Dordrecht  
The Netherlands

+31 (0)78-632 36 90  
www.dlsbv.nl  
info@dlsbv.nl



DLS has over 55 years of experience in powertrain solutions for heavy duty vehicles and machinery. We are a customer and service oriented technical organization that provides powertrain products and parts, and specialized service and maintenance. In addition to our traditional powertrain solutions, we extended our product range with solutions for green & smart mobility.

Our green mobility solutions for better conditions for people, climate and environment help to make drive systems and stationary equipment more sustainable. They are suitable for both new (OEM) drive systems and drive systems of existing vehicles and machines (retrofit). One example of our green mobility solutions is fuel cell technology.

At DLS we supply and integrate multiple A-brand fuel cell solutions for your hydrogen electric

powertrain and stationary equipment, like the Toyota fuel cell module. These fuel cells are specially designed for heavy duty applications, such as large construction equipment, and hydrogen generator sets. The fuel cell modules range from 60 to 80 kW, offer a wide output voltage range, and are available for OEMs or as retrofit.

Based on your wishes and requirements, we advise the best solution for you. We can deliver the complete system, including related equipment, extensive installation and operation manuals, and, if needed, technical support. Optionally, we can deliver an integrated system solution, including engineering, assembly, and commissioning.

**Doeko B.V.**  
Hendri Sas  
Thomas van Heereveldstraat 1  
6551 AK Weurt  
The Netherlands

+31 (0)24 679 07 50  
www.doeko.nl  
h.sas@doeko.nl



For more than half a century, Doeko is specialized in High tech tooling. Through those years, Doeko gained a lot of experience in cutting tools, plastic injection tools, precision mechanics and mechatronics. Experience that can not be matched with machines or systems. We design and manufacture high-tech components, modules and systems based on precision engineering and machining. We look at your complete production process with a helicopter view and then design the optimal assemblies down to the smallest detail. Doeko is able to produce your components to the highest precision. In our own modern workshop, we work with 53 highly skilled and experienced people. Besides the people,

we work with 25 robots that can run 24/7. The engineering of tooling for your product, can be (partially) done by our inhouse engineers. Doeko believes in hydrogen and wants to help you in producing the right tools and machinery for your product. Whether you have a functioning production line, prototype or design. Together with us, we can bring your product to the next level! As a specialist in high precision tooling we believe that we can help you. When you want to discuss how we can help you with producing your product, please visit our website or contact us. We deliver the smartest solution for your production process!

**Douna Machinery B.V.**  
Hendrik Wijnja  
Hidalgoweg 1  
8938 BA Leeuwarden  
The Netherlands

+31 (0)58 2849 672  
www.douna.nl  
h.wijnja@douna.nl



Douna Machinery B.V. is a factory active in mechanical machine building for 100 years. Ultimate experience in prototype construction of various machines where the gas industry is the biggest part. With our own engineering department, we can assist from idea to assembly and production of complete machines. Nowadays Douna is connecting green technologies, for example for future energy supply or energy storage. In addition, precision large machining, certified welding, assembly and measuring in a conditioned measuring room are key words that belong to Douna's craftsmanship. The industrial hydrogen ecosystem in the Northern Netherlands is receiving a significant boost with the delivery of the WAviatER project in september 2023. Douna played a significant role in this project as

developing partner. With consortium partners an 1 MW Hydrogen production technology is built for the Aviation sector and Energy applications as demonstration facility on airport Eelde. On the roof of Douna Machinery factory 1400 solar panels generate 550.000 KWh of electricity per year. That is enough to provide about 200 households with power for a year. In addition, it will also save 124 tons of CO2. With this roof, Douna provides for its own electricity use and has the possibility to provide electricity to other companies on the industrial estate in the future. Douna Machinery is located in Leeuwarden, almost the center of 'the Hydrogen Valley' in the Northern of the Netherlands



### Duiker Combustion Engineers

Albert Lanser  
Turfschipper 91  
2292 JK Wateringen  
The Netherlands

+31 (0)174 282 700  
www.duiker.com  
sales@duiker.com



Duiker specializes in developing, designing, supplying, installing and servicing advanced combustion solutions, tailored to customer needs for liquid and gaseous fuels for the oil refining, chemical and process industry worldwide. At Duiker we believe in jointly realizing inventive solutions that make a meaningful contribution to people and the environment and hereby Duiker's motto is 'Thousands of process solutions, you can rely on our experience'.

The following products & technologies in relation to hydrogen are relevant:

- 1) Stoichiometry Controlled Oxidation (SCO) for conversion of fossil fired power stations into renewable ammonia (as hydrogen carrier) fueled power stations for zero CO<sub>2</sub> emission electricity.
- 2) Multi-Fuel Combustion Technology: engineered

flexible solutions for revamping existing process heater/furnaces from fossil fuels into low carbon or renewable fuels.

- 3) Stoichiometry Controlled Oxidation (SCO) for conversion of renewable ammonia (as hydrogen carrier) into high temperature heat for the process industries. This SCO technology is scalable, proven and commercially available.
- 4) Ammonia cracking technology, developed by Duiker based upon their proprietary SCO technology for converting renewable ammonia into affordable & pure hydrogen. This ammonia cracking technology has been developed for large, world scale ammonia cracking at low costs and for high conversion yields.

### Dumaco Woerden B.V.

Pieter Meinster  
Klompensmakersweg 9  
3449 JB Woerden  
The Netherlands

+31 (0) 348457 040  
www.dumaco.com  
woerden@dumaco.com

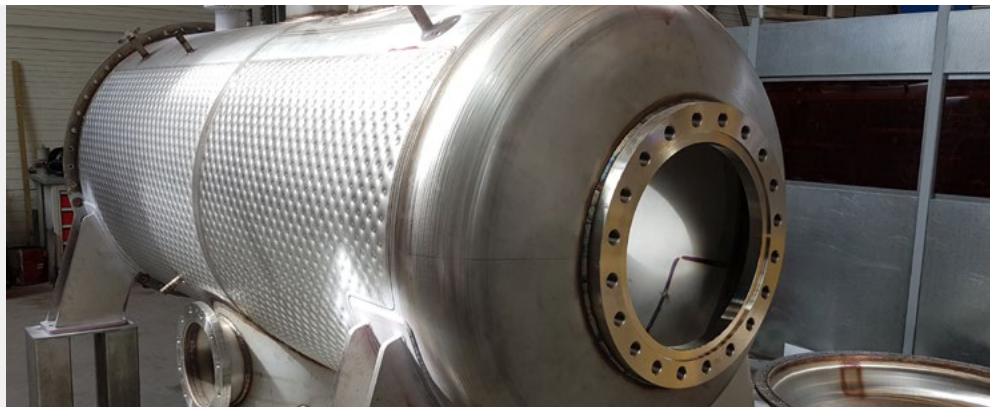

Woerden

Dumaco (Dutch Manufacturing Companies) is a brand of 9 metal working companies. With over 750 employees we are the one stop shop for all your needs when it comes to:

- Engineering
- Laser- / water cutting
- Tube laser cutting
- Bending / rolling
- Certified (robot)welding
- Machining
- Grinding / polishing
- Pickling & passivating

At Dumaco Woerden we are specialized in the engineering and production of components and welded assemblies in exclusively stainless steel, this to prevent contamination with carbon steel. In our state-of-the-art production location in Woerden we work with a team of 70 highly qualified

and certified employees. Materials we process are SS 304, SS 316, but also more specialized materials like (Super)Duplex and nickel alloys.

For the hydrogen market we are focused on the engineering and production of PED certified pressure vessels / piping and complete stainless steel skids for electrolyzer systems. We are fully certified to design and weld the components of a system as per applicable design code. Since we can do the engineering, calculations and certification in house we are very flexible in design, advise and delivery time. We are always looking for a partnership and cooperation with our customers and suppliers to make the difference.

### Dutch Boosting Group

Gijs Stigter  
Vendelier 57-C  
3905 PC Veenendaal  
The Netherlands

+31 (0)318 540 404  
www.dutchboostinggroup.nl  
info@dutchboostinggroup.nl



At Dutch Boosting Group, we are system thinkers for the living environment. Always with the bigger picture in mind. Continuously looking for new ideas. Our working method is based on a systematic approach. By explicitly balance needs and interests we believe to create sustainable solutions. We are driven by improvement and curious about new ideas and future-proof solutions. We innovate, we improve, we accelerate: that's how we boost!

We have been successfully applying our expertise for many years in complex Infrastructure projects, Spatial Development and Energy Transition. Sectors in which we see a crucial role for the application of hydrogen. In order to create the highest impact, we boost the application of hydrogen on various levels. Some examples:

- Quick Scans for organizations to determine the most suitable set of solutions, including hydrogen to attain its sustainable energy goals.
- Network analyses for governmental organizations to steer their policy making, by providing overview of stakeholders needs to adopt hydrogen applications, spatial distribution of local potential hydrogen availability and demand.
- Program/Process management of regional hydrogen programs and processes in order to accelerate the development and to stimulate local initiatives in order to boost innovation.

The challenges we face are complex. To find solutions, we are always open for joint ventures and collaborations in order to boost the implementation of hydrogen.

### Dutch Marine Energy Centre (DMEC)

Justin den Hartog  
Hellingweg 11D  
2583 DZ The Hague  
The Netherlands

www.dutchmarineenergy.com  
justin@dutchmarineenergy.com



DMEC is an international accelerator and service centre for marine energy solutions. We believe that marine energy will be a crucial driver to realise our global energy transition and foster sustainable growth. By advancing innovation, mobilising capital and shaping policies, we create multipurpose energy solutions for a wide variety of markets, including green hydrogen production.

Electricity produced using marine energy applications can be used for offshore or nearshore green hydrogen production. Possible ways of doing this vary from using wave energy converters for producing hydrogen at decommissioned platforms, to future use of salinity gradient technology and tidal turbines to produce hydrogen at existing infrastructures like the Afsluitdijk or the Eastern Scheldt barrier. We foresee a promising future for green hydrogen and marine energy is ready to be a part of this.



## DWG

Marcel van Veen  
Admiraal Lucashof 5  
3115 HM Schiedam  
The Netherlands

+31 (0)6 86 85 83 93 / +31 (0)10 760 86 00  
www.dwg.nl  
info@dwg.nl  
marcel.vanveen@dwg.nl



AHEAD OF TOMORROW'S CHALLENGES

Ahead of tomorrow's challenges. At DWG, we firmly believe technology has the power to make people's lives better. Technology has the potential to make the world more efficient, safer and more sustainable. Processes can be accelerated, maintenance costs can be reduced, re-work can be minimised, data can be secured, and it doesn't stop there. All technology will make the future a lot brighter and needs a dedicated expert who knows how to use the right technologies. An expert who can work out and understand your processes. At DWG, our office is full of such experts.

DWG delivers total asset process engineering & design, functional safety, hardware electrical & instrumentation, industrial automation & IT engineering (including cyber security) plus SLA for 7/24/365 maintenance contracting. DWG is specialized and certified partner for Siemens,

ABB and Wonderware. AutoCad and EPlan are used as separate hardware E/I tooling but COMOS as a true single database in the middle of digitalization, supporting the transition of document oriented organizations to more data centric, based on the DWG company (but also more and more production companies) vision and strategy. We add value by the DWG ITS (Industrial Things Server) by analysing data via wireless secure smart sensorics to generate domain KPI dashboarding including AI (Artificial Intelligence) and algorithms for customer specific decision criteria. DWG mainly works at projects in the BeNeLux in the 3 harbour regions Rotterdam, Amsterdam and Antwerp! Ready for the future and beyond. Design goes hand in hand with achievement: and we can do both.

## E&E advies

Theo Smit  
Helperpark 288  
9723 ZA Groningen  
The Netherlands

+31 (0)50 360 44 33  
www.eeadvies.nl  
info@eeadvies.nl

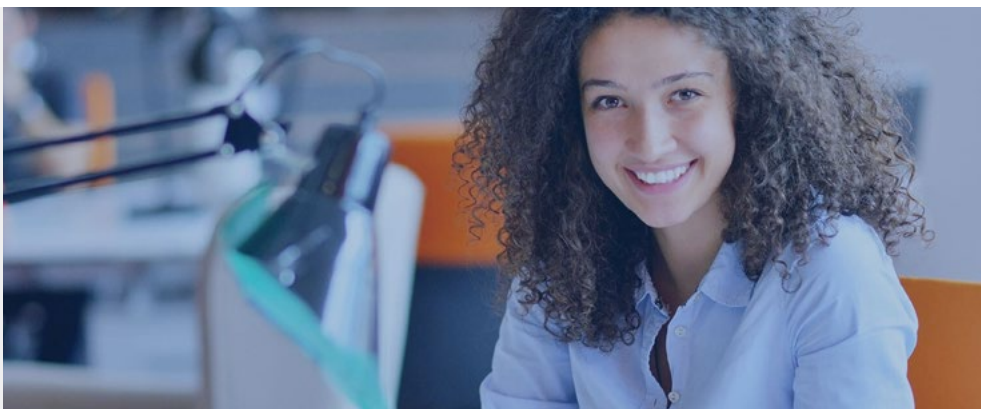

## E&E advies

Consultants of E&E advies focus on connecting the energy transition to economic development. E&E advies supports governmental organisations, the industry and public-private partnerships to develop ambitions, strategies and policy. We perform exploratory research, we advise on policy and strategy, we monitor and evaluate policy or business cases and provide program- and project management.

Our result-oriented approach is based on our wide experience with clients in industry, governmental organizations and research institutes and strong analyses based on both quantitative and qualitative data.

Recently, we worked on several hydrogen projects:

- We developed energy roadmaps for Dutch Provinces and municipalities;
- We performed exploratory research on hydrogen production, infrastructure and use in Fryslân and Drenthe. Based on in-depth research and interviews, we identified regional opportunities and actively involved stakeholders from industry, governmental organizations and universities in our research;
- We have performed analysis that provide insight in the economic value of the energy transition and presented the results in factsheets;
- We monitor climate ambitions of several Dutch municipalities and provinces.

**Eekels Technology B.V.**

Oscar Grooten  
PO Box 4  
9600 AA Hoogezand  
The Netherlands

+31 (0)88 799 12 75  
www.eekels.com  
o.grooten@eekels.com



For over 110 years, Eekels has been operating in the Marine & Offshore and Industry & Infrastructure markets. Its employees, totalling almost 600, carry out projects and maintenance & service operations in technical automation, electrical engineering and mechanical engineering.

Eekels has specific expertise in electrical drive systems, shore power connection systems, ship systems (including alarm and monitoring systems) and process automation. Eekels takes care of the entire process from engineering, panel building, implementation and start-up to maintenance and service.

We design, build and commission fuel cell systems including electrical conversion in a range from 100 kW to 500 kW and integrate them for vessels.

For the infrastructure we provide energy storage systems and provide electrical power with hydrogen as an energy carrier. These setups provide energy for construction sites and in harbour areas as mobile shore facility.

**Ekinetix B.V.**

Jaco Reijkerk  
Houtkopersstraat 17  
3334 KD Zwijndrecht  
The Netherlands

+31 (0)78 610 34 11  
www.ekinnetix.nl  
info@ekinnetix.nl



Ekinetix: leading advisory and engineering firm in the energy transition, with extensive expertise in hydrogen technologies. We cover the entire value chain, from concept development and feasibility studies to the complete realization of technical installations (EPCM).

Ekinetix engineers have been involved in nearly all novel product-market developments for hydrogen in the energy transition in the Benelux. This is possible by our extensive expertise in high-tech gases solutions.

We provide turnkey project management and system integration for technical installations, covering design, construction and commissioning. Innovative projects in (large scale) electrolysis, high pressure gases, liquid hydrogen, (multimodal) refuelling stations and distribution hubs, bunkering

for maritime and aviation sectors.

Our benchmark advisory work includes building blocks of current hydrogen policy and developments: A One-Gigawatt Electrolyser Design; Green Hydrogen Economy Northern Netherlands; Hydrogen: Opportunities for the Dutch Industry.

Our clients trust us in all aspects of the hydrogen value chain: industrial gases and energy companies, fuel retail, shipping, grid operators, public bodies and knowledge institutes. We are the connecting factor in the hydrogen value chain. We deliver innovations in sustainable energy, using our >25 y experience and broad network. If you have an innovative idea in energy transition, Ekinetix can help you realize it. Ekinetix. Realizing Energy Transition.



**Ekwadraat Advies B.V.**

Jan Zuidema  
Ynduksjewei 4  
8914 CA Leeuwarden  
The Netherlands

+31 (0)88 400 05 00  
www.ekwadraat.com  
info@ekwadraat.com  
jzuidema@ekwadraat.com



Ekwadraat guides and advises companies and entrepreneurs in the realization of projects in the field of energy saving, sustainable energy and energy saving.

For hydrogen projects, Ekwadraat provides (among other things):

- feasibility studies;
- subsidy applications;
- permits;
- certification;
- justifications for subsidy obligations and legislation and regulations;
- and PPA's.

**ElechHydro BV**

Jani Roland Holst  
Hoofdstraat 27  
9528 PB Buinen  
The Netherlands

+31 (0)6 533 57 507  
www.elechhydro.nl  
info@elechhydro.nl



ElechHydro contributes to the global energy transition. We do this with a new generation of innovative electrolyzers based on the Anion Exchange Membrane technology (AEM). Our goal is to develop highly efficient, fully adjustable and sustainable electrolysis systems with which green hydrogen can be produced at the lowest possible Total Cost of Ownership.

This competitive proposition is achieved through the application of innovative technologies that lead to high performance electrodes and a better connection to sustainable energy sources with a higher efficiency. With the upscaling of the production of the electrolyser stacks to series and mass production, further price reductions are realized.

ElechHydro develops and supplies electrolysis systems based on AEM technology with the following Unique Selling Points:

- Controllability of the system from 0% to 100%. This makes the system ideally suited to combine with intermittent sources such as solar and wind energy.
- Start-up speed of the system within one minute. Ideally suited for the combination with intermittent sources such as solar and wind energy.
- Comparable or higher efficiency than comparable technologies. This at both stack and system level (> 80% system efficiency)
- Low cost and fully recyclable (cradle to cradle). We do this by making little or no use of precious metals such as iridium and platinum, a simpler stack design, and a less complex Balance of Plant.

**Elestor B.V.**

Guido Dalessi  
Westervoortsedijk 73, Bldg BF  
6827 AV Arnhem  
The Netherlands

+31 (0)6 53 72 97 59  
www.elestor.nl  
guido.dalessi@elestor.nl



Elestor has introduced an innovative electricity storage technology for large scale stationary applications, based on flow battery, reducing the electricity storage costs to an absolute minimum. Low-cost active materials are used, combined with a patented system design and easy to manufacture, compact cells. This triple cost reduction strategy enables viable business cases, essential to stimulate the adoption of electricity storage and thus to accelerate the energy transition.

The technology has the potential to replace fossil power plants at GWh scale and has all the properties to become the equivalent in large-scale, long duration electricity storage of what Lithium ion is today for mobility.

The Elestor technology is 100% modular and any

desired MW/MWh combination can be designed, enabling very cost-effective bridging of long periods during which hardly renewable electricity is generated.

A unique feature is that the Elestor technology can be integrated in H2 infrastructures and electrolyzers, resulting in largely reduced production costs for green hydrogen. Elestor was granted the 'Offshore Wind Innovators Award 2022', juried by Vattenfall, Green Giraffe and the Technical University of Delft.

Fueled by a recent Series A investment of 30M€, in a round led by Equinor with also Vopak joining the investors team, as well as by agreements with clients strategically adopting its innovative storage technology, Elestor has embarked on an ultra-rapid growth path.

**Eltacon Engineering B.V.**

Riccardo Vitali  
Coenecoop 57  
2741 PH Waddinxveen  
The Netherlands

+31 (0)182 634 100  
www.eltacon.com  
sales@eltacon.com



Eltacon Engineering supplies gas treatment systems for the Power Industry and Oil & Gas market. Located in The Netherlands, Eltacon is an independent engineering contractor since the year 1987. Over the years we have obtained an excellent reputation in the design and fabrication of tailor made equipment.

For applications on the energy transition and related markets we have supplied several hydrogen treatment and mixing stations. In order to reduce carbon emissions hydrogen can be mixed to the current fuel gas stream to a suitable fuel gas mixture. By means of flowmeter, pressure reduction, measurement of Wobbe index etc. the downstream mixture will be regulated automatically. Eltacon will supply the complete treatment system based upon skid mounted units.

Reference projects have been delivered to (among others) Russia, Poland and Belgium and include natural gas mixing with hydrogen, nitrogen, BOG's and COG's.

For end-users, EPC contractors, turbines manufacturers and other clients Eltacon delivers high quality products with flexible services. The company itself is very flexible and is able to meet the variety of requests from the market.

The same as our clients, we are constantly striving for new solutions that minimize environmental impact. Conversely, they want to maximize productivity while generating a reliable supply of energy. Eltacon Engineering can meet those market needs, and others, thanks to our extensive experience and recognized know-how.



### Emmett Green

Michiel Wildschut  
Professor Snijdersstraat 2  
2624 RA Delft  
The Netherlands

+31 (0)85 06 06 485  
<https://emmettgreen.nl>  
wildschut@emmettgreen.nl

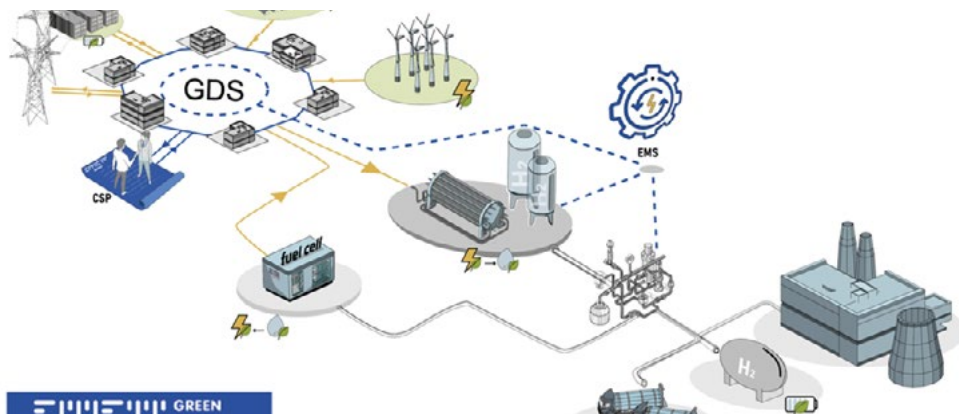

Emmett Green is an innovative company driving the energy transition. We do this by combining deep knowledge of electrical engineering, heat, hydrogen, batteries, financing, IoT and algorithms, projects management and asset management within one company. Emmett Green has been involved with several hydrogen projects and the company has an extensive knowledge base in the subject. An example of such a project is the design, financing, realisation of an electrolyser for sustainable business operations or transport.

Emmett Green is realising several Energy Hub projects within the Netherlands and has developed a state of the art Energy Management System (EMS). An Energy Hub allows for local production, conversion, storage and

consumption of different types of energy carriers. The EMS will monitor, control and optimize the energy flows within the Energy Hub. The EMS can be seen as the brain of the Hub. Emmett Green's EMS allows for the connection of several assets, under which hydrogen systems, such as fuel cells and electrolysers. Emmett Green is also conducting research on the implementation of fuel cells into electric micro-grid configurations.

The combination of in-depth technical knowledge, financing and project management allows us to create a suitable tailor-made solution for your energy case. For more information, please visit our website or contact us via mail or phone.

### Enablemi

Erik Matien  
Friesestraatweg 213  
9743 AD Groningen  
The Netherlands

+31 (0)85 301 10 50  
+31 (0)6 24 58 52 02  
[www.enablemi.com](http://www.enablemi.com)  
[info@enablemi.com](mailto:info@enablemi.com)  
[erik@enablemi.com](mailto:erik@enablemi.com)



Enablemi is specialized in developing and managing innovation projects, which contribute to the Sustainable Development Goals. Regarding innovation, we believe the technology is at the heart of innovation, but it cannot go without a strong network and good collaboration. Therefore it is our aim to bring together companies, educational and knowledge institutions, governments and end-users (quadruple helix) to accelerate development of new energy technologies.

We have consultants with technical, financial, marketing and project management backgrounds. Who all use their qualities to accelerate the energy transition by coordinating innovations from their origin, the idea, to a plan, to the implementation of a finished product or service.

A snapshot of recent activities showing our involvement with regards to hydrogen technologies:

- Development of several research projects for various consortia involving Eindhoven University of Technology, on the topics of system integration and asset planning.
- We researched the feasibility of setting up a hydrogen boat-racing class in the North of the Netherlands, as an impulse-instrument for the Northern hydrogen economy.
- Involved in consulting, development and project management of multiple PAW (Programma Aardgasvrije Wijken) field labs involving the transition from fossil gas to sustainable alternatives including full or partial hydrogen substitution.
- Arranging funding for startups and companies, specialized in hydrogen technology.

**Endress+Hauser**

Arjan van Ginkel  
Nikkelstraat 6  
1411 AJ Naarden  
The Netherlands

+31 (0)6 5396 3686  
www.nl.endress.com  
arjan.van.ginkel@endress.com



**Endress+Hauser**

Endress+Hauser is the global supplier of measuring instruments for production, generation, distribution, storage and use of hydrogen. The product portfolio consists of process and lab instrumentation including flow, level, pressure, temperature, gas and liquid analysis devices. Instrumentation health can be monitored with special Heartbeat Technology and made available via the Netilion eco system.

**ENERGY B.V.**

Katharina Bouchaar  
Burg. J.G. Legroweg 45a  
9761 TA Eelde (Groningen)  
The Netherlands

+31 (0)6 49 05 20 62  
www.energy.nl  
info@energy.nl



**Energy**

The Hydrogen Valley Experts



ENERGY is an international engineering consultancy specialised in the development of Green Hydrogen ecosystems, also known as Hydrogen Valleys. We provide the following technical and strategic consulting services:

- Project development
- Technical project design
- Identification & Application for EU Funding
- Project management
- Stakeholder engagement & public awareness
- Capacity building

In cooperation with our international partners, Energy has led the technical design, and supported the development and delivery of several Hydrogen Valleys across Europe such as the BIG HIT project in the Orkney Islands, UK, the HEAVENN project in the Northern Netherlands and the GREEN

HYSLAND Flagship Project in Mallorca, Spain as well as EU Hydrogen IPCEIs. For these multi-million, integrated cross-sector projects we provide technical support, and bring together international stakeholders from the private sector, government and civil society, to develop economies of scale and bring down costs to support the implementation of green hydrogen as a key pillar of the energy transition. In order to create a full-fledged hydrogen economy, we also contribute our more than 20 years of experience in the hydrogen sector to support immersive training and educational programmes. ENERGY is also an active member of the European Clean Hydrogen Alliance and the EU Clean Energy Island initiative.



**Energy Storage NL**

Jeroen Neefs  
Postbus 20122  
7302 HC Apeldoorn  
The Netherlands

[www.energystoragenl.nl](http://www.energystoragenl.nl)  
[info@energystoragenl.nl](mailto:info@energystoragenl.nl)



Energy Storage NL represents the Dutch energy storage sector and promotes the development of technological solutions for storing energy in various forms. This contributes to building a sustainable and reliable system capable of meeting energy demands consistently.

insights to efficiently address obstacles in the energy market, thereby accelerating the Dutch energy transition.

There are numerous methods for energy storage, including in electrons (such as batteries), heat (like a thermal buffer), or molecules (such as hydrogen or ammonia storage). ESNL utilizes various working groups to obtain up-to-date knowledge about bottlenecks and technical possibilities from its members, which it then utilizes in its network and advocacy activities. The Molecule Storage working group, among others, leverages its diverse membership to gather and consolidate a variety of

**ENGIE Services Nederland N.V.**

Pieter Blok  
Kosterijland 20  
3981 AJ Bunnik  
The Netherlands

[www.engie.nl/zakelijk/technische-dienstverlening](http://www.engie.nl/zakelijk/technische-dienstverlening)  
[pieter.blok@engie.com](mailto:pieter.blok@engie.com)



ENGIE is an international leading company in the business of technical services and renewable energy generation. The 6.000 employees of ENGIE in the Netherlands support consumers, institutions and commercial companies to make the change to a more sustainable way of working and living. At ENGIE, we believe that Hydrogen will accelerate the transition to green energy in regions around the world for the benefit of all. Green Hydrogen, produced through the process of electrolysis will provide:

- Decarbonised solutions in mobility on both water and land
- Grid stabilisation services to solve congestion problems
- Storage capacity of intermittent energies

Renewable hydrogen, or hydrogen as a by-product, is a versatile energy vector that can be used to decarbonize many applications. At ENGIE, we offer solutions that are present across the entire value chain: strategy, design, engineering, construction of energy efficient assets, digital platforms, operations, and financing. We are committed to delivering the expected results. Our proximity to our customers allows us to enhance local resources, through production and decentralized Hydrogen storage for local uses.

Are you a company or local authority looking for partners capable of providing you support and advisory to develop carbon free solutions? ENGIE can work with you in your zero carbon transition goals, design integrated turn-key energy solutions that meet your specific needs.

### EnTranCe | Centre of Expertise Energy

Zernikelaan 17  
9747 AA Groningen  
The Netherlands

+31 (0)50-595 65 00  
www.en-tran-ce.org  
info@en-tran-ce.org  
l.j.van.der.velde@pl.hanze.nl



EnTranCe|Centre of Expertise Energy contributes as a learning, practice-oriented knowledge community to a clean, renewable and affordable energy supply. Scientists, students, businesses and authorities all come together at our center of expertise to share knowledge. With our premise people in power, we develop the innovations that are much needed for the energy transition and strengthen the regional knowledge economy.

The multidisciplinary energy research carried out by EnTranCe is mainly on the level of villages, districts, neighborhoods or companies. This is where large-scale energy suppliers and infrastructure meet small-scale, local energy initiatives. And this is where the main breakthroughs will be needed to ensure a successful transition.

#### Project examples:

- Groene Waterstof Booster: helps entrepreneurs to realize hydrogen innovations and ideas. With a financially attractive scheme (voucher program), we give companies access to a strong and broad network in the Netherlands and unique test opportunities on the grounds of EnTranCe.
- Waterstof Innovatie Netwerk Groningen: a hydrogen facility which companies and organizations can use to accelerate the development of hydrogen techniques. With WING, SMEs can host hydrogen training sessions for staff, conduct physical tests and demonstrate technology.
- Hydrohub MegaWatt Test Centre: a state-of-the-art research facility on the grounds of EnTranCe to optimize and scale up the production of green hydrogen via electrolysis.

### EoxTractors B.V.

Thomas Hieltjes  
Westervoortsedijk 73 GE-29  
6827 AV Arnhem  
The Netherlands

+31 (0)26 7009 708  
eoxtractors.com  
info@eoxtractors.com



EOX Tractors produces emission free tractors through unique technology and groundbreaking designs for agricultural and infrastructural construction purposes. As an innovative agile start-up, working with commercial partners and academic institutions, we stay ahead of the market in delivering zero-emissions vehicles. In 20 years' time, all tractors will be electric. Many farmers have already laid a good foundation for this transition by investing in solar power, wind energy or even an electrolyzer. Today we are therefore designing and building the machines to work fully electric or on hydrogen as front runners in the industry. The EOX platform is designed as a smart modular chassis with proven electric powertrain technology for optimal efficiency. Our unique electric drivetrain powers four independently controlled wheels. The availability of this technology makes our platform ready for a wide variety of autonomous applications.

Based in Arnhem at Industry Park Kleefse Waard, EOX Tractors operates in the Dutch center of hydrogen technology development. Together with affiliated partners connected through our investor's network we are able to stay ahead with zero-emission and autonomous productions and developments.



### Erez Energy

Ruben Burggraaf  
Trompenburgstraat 2C  
1079 TX Amsterdam  
The Netherlands

+ 31 (0) 20 210 1695  
<https://erezenergy.com/>  
[info@erezenergy.com](mailto:info@erezenergy.com)



## EREZ ENERGY

GREEN HYDROGEN

Erez Energy produces green hydrogen locally as a service for the industry and heavy mobility that need green hydrogen in their future energy mix.

Our goal is to be the catalyst in the hydrogen transition for the industry. With our locally produced green hydrogen we enable the industry to start with the hydrogen transition by mixing green hydrogen with natural gas or gray hydrogen.

Our modular and standardized green hydrogen systems are located near the industrial offtaker. With our approach green hydrogen becomes available on a short term and on locations where hydrogen pipeline infrastructure isn't expected

soon. Our approach is a first step in the hydrogen transition and therefore mitigates the financial risks that the uncertainties of this transition might cause.

As project developer Erez Energy takes care of the complete scope of the hydrogen production, from investment to operation. As a consultant, Erez Energy helps companies with insights and feasibility studies.

### ERIKS Nederland

Teun Blik  
Toermalijnstraat 5  
1812 RL Alkmaar  
The Netherlands

+31 (0)88 855 85 58  
[www.eriks.nl](http://www.eriks.nl)  
[info@eriks.nl](mailto:info@eriks.nl)



## ERIKS

ERIKS is a specialized industrial service provider that offers a wide range of technical products, co-engineering and customization solutions, as well as related services for all possible hydrogen applications. We help customers in a variety of industrial segments to improve their products' performance and reduce their total cost of ownership. Over 5000 skilled colleagues worldwide serve customers in their original equipment manufacturing (OEM) and maintenance, repair and overhaul operations (MRO).

Our technical know-how is the basis of our specialism. We have built up deep expertise in the areas of sealing & polymer, gaskets, valves & instrumentation, industrial & hydraulic hoses, industrial plastics, power transmission & bearings and tools, maintenance & safety products.

We supply A-brands as well as our own ERIKS products. Besides we have our own departments for engineering, clean manufacturing, assembly, condition monitoring, smart asset management, inspection and field service engineers.

At ERIKS, we stand for doing good business. We value long-lasting relationships with all our stakeholders and contribute to a better and more sustainable society. ERIKS sees hydrogen as an important sustainable energy carrier for the near future. We are working on building this hydrogen fuelled world by combining hydrogen knowledge and products available in all our expertise areas. Our team of hydrogen specialist in the Netherlands is at your service for a customized solution.

**E-Trucks Europe B.V.**  
André Beukers  
Leemskuilen 41  
5563 CL Westerhoven  
The Netherlands

+31 (0)40 204 22 93  
www.e-truckseurope.com  
info@e-truckseurope.com



E-Trucks Europe develops, produces, sells and rents hydrogen trucks. This concerns heavier trucks with an energy-consuming structure such as garbage trucks, but also vehicles with a crane, hook-arm system, tipper or cooling installation on board. We have been doing this as a family business since 2010 from our workshops in Westerhoven (the Netherlands) and Lommel (Belgium).

In 2013, we launched our proof of concept of a hydrogen refuse truck, which we used to collect waste paper in the city of Eindhoven for a year. Then we took the time to use the experiences of the test period to improve the truck and the hydrogen-electric system, in which we use a fuel cell. We have now delivered zero-emission refuse

trucks to various Dutch cities such as Amsterdam, Breda, Eindhoven, Groningen and Helmond. We also have orders from Belgium, Germany and Italy. There is great interest from almost all countries in Europe for our hydrogen refuse trucks. The European Commission is stimulating this development based on its vision for the future of hydrogen and its Clean Vehicles Directive to green mobility.

As E-Trucks Europe we actively collaborate with more than 70 chain partners. In practical terms, this means a.o. that we develop projects together around new hydrogen refuelling stations. If you are also interested or if you have any questions, please do not hesitate to contact us.

**EY | Ernst & Young**  
Niels van den Broek  
Westervoortsedijk 73 - Gebouw LB  
6827 AV, Arnhem  
The Netherlands

+31 (0)6 2908 3926  
www.ey.com/nl  
niels.van.den.broek@nl.ey.com



At EY, we are committed to a better working world. We do this by working together on a future-proof and sustainable energy sector. We are keen to live up to our commitment to sustainability and eager to support organizations in their distinct sustainability efforts.

On your sustainability journey, EY teams can help you reach your goals by designing tax frameworks and risk management methodologies to accelerate transition, decarbonize your supply chain, and genuinely green business operations. To support this, we help you stay aware of policy developments and their impact and assist with securing incentives and funding and complying with new tax and non-financial reporting obligations.

EY teams insight creates a bird's eye view of your sustainability strategy, supporting and flexing across your enterprise. This insight allows us to bring in key players at vital stages, sharing our technical and market experience related to the tax, legal, governance and workforce challenges you face during your sustainability journey.

With the use of these financial, grants & incentives, tax and legal expertises, EY shares its sector knowledge about hydrogen applications. Initiating consortia of (inter)national companies and applying for Dutch and European grants and incentives is an important pillar for the (knowledge) development of new hydrogen and fuel cell solutions. In this way, EY contributes to the transition to a sustainable future and the creation of long-term value.



## Feenstra

Jan Liefing  
P.O. Box 88  
8200 AB Lelystad  
The Netherlands

+31 (0)320 278 000  
www.feenstra.com  
info@feenstra.com



Feenstra started in 1947 and is since its establishment a major player in the Dutch market for installation and services of energy supply systems in dwellings. Both for private residential and housing corporations. These energy supply systems consist of solutions for heat, cold and electricity generation and storage. With more than 800 field service engineers, Feenstra is also active in the field of renewable energy solutions and the energy transition. We are front-runners with our partners in the field of hydrogen-projects, for existing and new buildings. For Feenstra's 800,000 customers we are always looking for new solutions whereby sustainable and comfortable living play a central role.

Technology Centre Europe  
Van der Klok Beheer BV  
Technology Centre Europe FINN BV  
P.M. van der Klok  
Veenstraat 11  
9502 EZ Stadskanaal  
The Netherlands

+31 (0)599 622 216  
www.finn.nl  
peter@vanderklok.nl



TCE Van der Klok Beheer and TCE FINN are Netherlands based companies. They started in 2011 to streamline research, engineering, design and manufacturing components to finalize and bring to market innovative, green technologies designed to operate in the current world infrastructures.

This is a brief history summary of the TCE companies including the development of its technologies and products. In addition, an overview of the principles involved, a description of the products, testing protocols and results, and the current and future outlook for the company. This will be followed by sales projections, market development strategies and opportunities, growth needs and recognized challenges.

TCE has many years experience in engineering and

production Hydrogen electrolyzers. The TCE Hydrogen System is a patented electrolytic retrofit technology for diesel engines. The product gases (oxygen and hydrogen) are an enhancement additive to the diesel fuel, not a fuel replacement. Using water, the product gas is produced in pods via an electrolytic process near the engine. The amount of gas produced is directed by the integrated computer system and determined by the power load of the engine. The harder the engine works, the more product gas is produced. It is then safely injected into the airstream just prior to combustion. TCE is specialist in machining high precision volume Electrolyser part and Electrolyser assembling.

**Fluidwell B.V.**

Eric Rath  
Voltaweg 23  
5466 AZ Veghel  
The Netherlands

+31 (0)413 343786  
www.fluidwell.com  
e.rath@fluidwell.com



Fluidwell develops and supplies products for use in potentially explosive environments in particular.

In more than 30 years we have grown into a major international OEM partner in measurement and control technology, with applications in the oil, gas and hydrogen industry. Our core expertise is the development, certification, assembly and international marketing of ATEX, IECEx, CSA and FM certified products.

Within hydrogen, we focus on developing and assembling electrolyzer systems based on PEM and AEM in collaboration with our strategic partners. Our focus is on decentralized hydrogen production locations using our standardized connectable systems of 50-500kW, which are typically fed by an intermittent source. High

efficiency, durable and low total cost of ownership are key parameters with a focus on applications up to 10MW.

In addition, Fluidwell has developed a Weights and Measures certified truck-dispenser system that is used throughout Europe on tube trailers to supply hydrogen filling stations (HRS), large-scale consumers and storage locations.

In the supply chain for safe hydrogen production, we are internationally active in several areas and we are looking for new partnerships.

**Fluor**

Wouter van der Bijl  
Taurusavenue 155  
2132 LS Hoofddorp  
The Netherlands

+31 (0)23 543 24 32  
www.fluor.com  
wouter.van.der.bijl@fluor.com



Fluor is a global, publicly traded engineering, procurement, construction (EPC) and maintenance company. We work with clients in diverse industries around the world to design, construct and maintain their capital projects.

Fluor has more than 46 years of experience in the hydrogen industry with 50 plants producing a total of more than 2,300 million cubic feet per day of hydrogen, including the world's largest hydrogen production plant at the time.

Moreover, Fluor has its own independent electrolysis expertise, and knows the licensors of the basic elements and the developers of the hydrogen electrolyzers applying these technologies. With this knowledge, we can assist clients to select the right application for their objectives.

Fluor in The Netherlands offerings:  
We successfully executed projects in Europe for

more than 75 years using a multi-office execution approach. With Fluor's offices in Hoofddorp, Bergen op Zoom, Geleen and Rotterdam, plus Stork, A Fluor Company, we can support clients with additional technical and project support. Our comprehensive solutions span the entire project life cycle and deliver capital efficiency. Industries served includes Advanced Technologies & Life Sciences, Oil & Gas, Refining, Chemicals & Petrochemicals, Gas Processing & Underground Gas Storage.

- Conceptual Studies, Full Front End Engineering and Design
- EPC and Project Management Consultant (PMC) capabilities
- Zero Base Execution
- Value Improvement Programs
- Organizational Effectiveness
- Integrated Partnership Programs



## FME

Jelle Blekxtoon  
Zilverstraat 69  
2718 RP Zoetermeer  
The Netherlands

+31 (0)79 353 11 00  
www.fme.nl  
internationaal@fme.nl



FME is the Dutch employers' organisation in the technology industry. The 2,200 affiliated companies include technology start-ups, trading companies, small and medium-sized industrial enterprises as well as large industrial conglomerates. Our members are active in the fields of manufacturing, trade automation and maintenance in the metal, electronics, electrical engineering and plastics sectors.

Around 400 members are active in the renewable energy sector and 130 members in the hydrogen sector. Together with our members we coordinate and participate in multiple hydrogen projects in the Netherlands and in an international setting.

FME members employ a total of 220,000 people, have a combined turnover of € 91 billion and their exports total € 49 billion.

We connect and mobilize companies, knowledge institutes, end users and investors in order to find solutions to the global challenge for a greener future. Please connect with us if you are looking for a specific company, product or service. Let's work together!

## Fountain Fuel

Stephan Bredewold  
Koninginnegracht 192  
2514 AB Den Haag  
The Netherlands

+31 (0) 6 5363 5865  
www.fountainfuel.com  
info@fountainfuel.com



Fountain Fuel is building a well-established network of 30 zero-emission energy stations in Europe by 2028, where green hydrogen refueling and e-charging are combined. This way, we provide the best of both worlds.

We offer a reliable, outspoken and flawless experience at our stations. Our diverse and knowledgeable team continuously improves our station design and operations, providing best-in-class reliability and quality for our customers. We use proven technologies and collaborate with robust partners such as Linde Engineering. Our operational station in Amersfoort acts as the blueprint for our future installations, with a benchmarked uptime of over 98.23% since opening.

As a result, we have already created a strong brand

with a positive connotation. The presence of Fountain Fuel means added value for project developers and governmental organizations. We create sincere partnerships and regional value chains, ensuring long-term relationships with off-takers, suppliers, governmental organizations and knowledge institutes, to maximize shared value and business results.

In May 2023 we opened our first Fountain Fuel in Amersfoort, which will be followed by Nijmegen and Rotterdam in 2024. In The Netherlands, we have 7 stations in the pipeline and 6 more in Sweden. Several leads are currently under investigation in Germany, France, Spain and Portugal. This means we are on track for reaching our 30-station goal, accelerating the transformation to sustainable mobility.





### Future Proof Shipping

Marjon Castelijns  
Weena 505  
3013 AL Rotterdam  
The Netherlands

+31 (0)10 800 54 34  
www.futureproofshipping.com  
start@futureproofshipping.com



Future Proof Shipping (FPS) offers zero-emissions marine transportation services to enable players across the value chain make the transition to zero-emissions. We are connecting and enabling the entire maritime and green energy value chain, starting with logistics service providers and cargo owners who are ready to take the lead.

As a zero-emissions vessel owner, we are building our own fleet of zero-emissions inland and short-sea vessels, which we offer for charter. With our zero-emissions advisory, we are enabling others to make the transition to zero-emissions through technical, financial, and commercial support as well as project development and management.

Over the next five years, we aim to build and operate a fleet of 10 zero-emissions inland and short-sea vessels based on long-term time charter contracts to operators, logistics service providers and cargo owners/shippers. We do this by retrofitting existing diesel-propelled ships in partnership with other investors or their current owners who are looking to adopt a zero-emission business model.

One of our current projects is to retrofit the Maas, an inland container vessel to sail 100% on zero-emissions hydrogen fuel.

### N.V. Nederlandse Gasunie

Helmie Botter  
Concourslaan 17  
9727 KC Groningen  
The Netherlands

+31 (0)50 521 91 11  
www.gasunie.n  
info@gasunie.nl



Gasunie is a leading European energy infrastructure company. The Dutch state is our sole shareholder. Our core activities are gas transport and gas storage. We serve the public interest and facilitate the energy transition by providing integrated infrastructure services.

In the Netherlands and the northern part of Germany, Gasunie operates infrastructure for the large-scale transport, storage and conversion of gas. At the moment, this is mainly natural gas, but the energy transition is increasingly shifting towards CO<sub>2</sub>, green gas, heat and hydrogen. Our infrastructure, services and geographical position mean that we are at the heart of the north-western European energy market.

By developing new value chains, in close cooperation with Germany and North Sea countries, Gasunie contributes to maintain the strong Dutch position as a significant energy hub and gateway for energy flows to north-western Europe. This is vital for an affordable and reliable energy supply of northwest Europe.

On the way to becoming a zero-emission society, natural gas is increasingly being replaced by hydrogen, especially in manufacturing and industry. By 2030, Gasunie has developed large-scale transport and storage infrastructure for hydrogen in the Netherlands and northern Germany that connects hydrogen suppliers with hydrogen buyers.

**gAvilar B.V.**

Rob van der Heijden  
Kamerlingh Onnesweg 63  
3316 GK Dordrecht  
The Netherlands

+31 (0)85 489 71 30  
www.gavilar.nl  
info@gavilar.nl /  
rob.vanderheijden@gavilar.nl



gAvilar specializes in gas pressure regulation. We produce regulators and systems (stations) including safety devices for network companies and industry in the world. Mainly still for natural gas but more and more for other gases, because of the energy transition, like biogas (green gas) or hydrogen. Our products are suitable for hydrogen, confirmed by Kiwa for some specific ones, and are therefore used in several pilot projects in The Netherlands.

Projects H2 in Lochem and Wagenborg  
gAvilar is a leading partner in development projects for hydrogen use in homes. gAvilar built the hydrogen measuring and control installation in Lochem and Wagenborg.

Furthermore, we have used standard natural gas regulators and components, and the electronic

components naturally comply with the correct Atex classification. We have also devised a well-functioning solution for odorizing hydrogen with a shelf life of 5 Nm<sup>3</sup>/h. We can even odorize at the right level from 1 Nm<sup>3</sup>/h.

H<sub>2</sub> mixing with natural gas and accurate measurements for billing purposes?  
gAvilar B.V. developed a compact and robust energy measurement system for gas mixtures, including hydrogen. A cost-effective solution with the accuracy of a gas chromatograph, but without the need for regular calibration and maintenance-free. The system consists of the latest Volume Converter gFlow1500 in combination with the Mems gasQS™ flonic sensor, which creates a certified energy measurement.

**GF Piping Systems**

Willem Kool  
Lange Veenteweg 19  
8161 PA Epe  
The Netherlands

+31 (0)578 678 222  
www.georgfischer.nll  
nl.ps@georgfischer.com



As the leading flow solutions provider for the safe and sustainable transport of fluids, GF Piping Systems creates connections for life. GF supplies high-quality plastic piping systems and related products for industrial applications, water/gas utility and building technology. GF connects resources, technology, and people, enabling positive change for a better future. Creating intelligent products and solutions for every flow application makes our world more connected and ensures the safe preservation and transportation of global (fluid) resources.

We offer holistic solutions for the hydrogen economy: from hydrogen production to storage and transport/distribution to utilization. With many years of experience in the field of gas

supply and industrial water treatment we have a comprehensive portfolio of high-quality and reliable solutions for hydrogen technology. For our product lines ELGEF PLUS and MULTI/JOINT 3000® PLUS system we have already received the KIWA certificate AR214 \*Suitability of hydrogen gases\* and thus offer a complete range for hydrogen distribution.

In the field of hydrogen production, GF Piping Systems can create added value thanks to its broad product portfolio and many years of experience in water treatment, cooling applications and customer-specific product design and prefabrication, which are all efficiency-increasing, weight-saving and corrosion-resistant.



**Green Energy Park Global B.V.**

Bart Biebuyck  
Wilhelminakade 173  
3072 AP Rotterdam  
The Netherlands

+32 479 75 62 32  
gep-global.com  
info@gep-global.com



**Green Energy Park**

Green Energy Park Global is a vertically integrated, renewable energy franchise, that shares know-how, technologies, experience, and best practices with its global members. We primarily focus on hydrogen technology applications and champion hydrogen and its derivatives as the premier renewable energy carrier. Our franchise endeavours to develop, finance, construct, and manage renewable energy facilities under a common brand, uniting upstream, midstream, and downstream operations around shared values and a common mission.

At the heart of our operations are two monumental projects:

Green Energy Park Piauí in Brazil is a 10GW green hydrogen and ammonia production plant in the special economic zone of Parnaíba. Strategically

positioned adjacent to the newly developed port infrastructure of Luís Correia, the plant boasts seamless export logistics. Green hydrogen produced here will be transported to Krk, while the remaining quantity will be distributed to various ports across the globe to serve industrial off-takers.

Green Energy Park Krk in Croatia is a unique midstream facility set to import and distribute 10 mln tons of renewable ammonia annually. With its deepwater seaport and terminal infrastructure, it unlocks the value chain for renewable ammonia distribution throughout South-Central Europe. The facility boasts direct access to a deepwater seaport, on-site ammonia storage, and modern infrastructure, offering efficient and cost-effective distribution channels.

**Platform Groene Hart Werkt!**

Yolanda Ledoux  
P.O. Box 13  
2400 AA Alphen aan den Rijn  
The Netherlands

+31 (0)6 46 97 32 05  
www.groenehartwerkt.nl  
yledoux@alphenaanandenrijn.nl

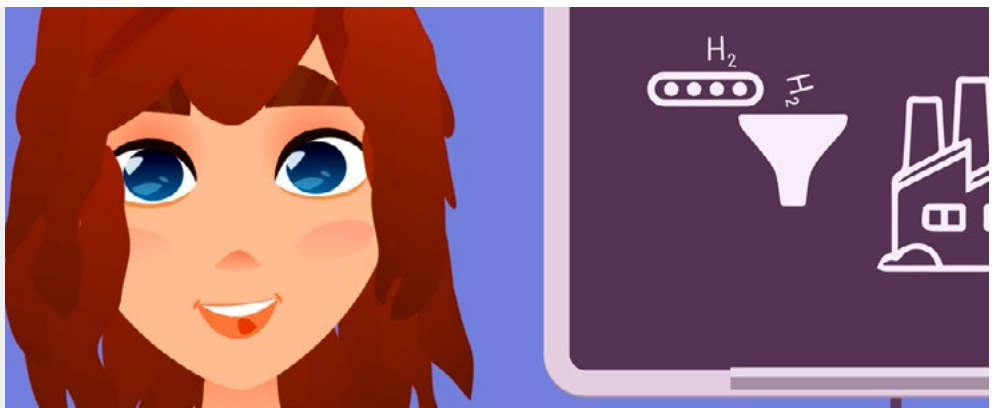

Platform Groene Hart Werkt! (PGHW) is the regional platform for circular economic initiatives in 'The Green Heart' of the Netherlands. In co-operation with ten townships in the middle of the country PGHW inspires, connects and facilitates entrepreneurs, start-ups, council representatives and students in all circular economy aspects. A major part is dedicated to the hydrogen business.

Building a sustainable economic future means co-operation in many ways. By facilitating and sharing knowledge between partners in our network we contribute to a proper circular economy for our region and country. The hydrogen business is on top of our list. Not only

we contributed to some concrete projects but we also work together with an innovation centre and university students on a hydrogen project in the automotive industry: the 'Hydrogen Education Bus'. An animation movie about the meaning and application of hydrogen was made in co-operation with a consultancy and engineering firm and issued by us. This year together with Provincie Zuid-Holland we started a 'regional hydrogen program'. Purpose of this program is to stimulate the hydrogen economy and the use of zero emission energy carriers in our region.

Contact us to see if we can help you with your circular and hydrogen business and ideas!

### Groningen Airport Eelde NV

Jonas van Dorp  
Machlaan 14a  
9761TK Eelde  
The Netherlands

+31 050 309 70 70  
groningenairport.nl  
info@gae.nl



Groningen Airport Eelde is a regional airport in the Netherlands and serves as an important testing and demonstration ground for the sustainable aviation industry. As a testing ground, it offers a unique environment for the development and validation of innovative aviation solutions. The airport actively seeks partnerships and initiatives that can contribute to the advancement of sustainable aviation practices. It focuses on various application areas, including unmanned aviation, green energy production and storage, zero-emission ground operation (such as our hydrogen ground power unit), refueling infrastructure for electric and hydrogen-powered aircrafts and sustainable aviation fuels. It has a special focus on hydrogen application in aviation; as Hydrogen Valley Airport, it aims to develop hydrogen ecosystem including green hydrogen

production, distribution, and usage. The starting point is the existing 22 MW solar farm, the largest airside solar park at an operational commercial airport, and its location in the heart of Europe's first official Hydrogen Valley.

By collaborating with various stakeholders, Groningen Airport Eelde aims to foster knowledge exchange, share best practices, and accelerate the development of sustainable aviation technologies. The airport serves as a vital link in the value chain, facilitating the testing and implementation of emerging technologies and solutions that can shape the future of aviation.

### Groningen Seaports

Robert van Tuinen  
Handelskade Oost 1  
9934 AR Delfzijl  
The Netherlands

+31 (0)596 640 400  
www.groningen-seaports.com  
info@groningen-seaports.com



Groningen Seaports: Hydrogen hub of Europe. Groningen Seaports is the port authority for the port of Delfzijl, Eemshaven and the adjoining industrial sites. We provide the complete package of port services to industrial and commercial clients. In addition to this, the Eemshaven plays a central role in the development of the energy-related industry.

In this capacity, Groningen Seaports supports and strengthens the production of green hydrogen. There are multiple hydrogen projects in development within the Delfzijl and Eemshaven area. These are projects relating to the construction of electrolyzers and hydrogen plants, the creation of specific port facilities, the development of a plastic pipe system

(‘backbone’), but also the use of hydrogen in public transport and the development of hydrogen filling stations. Groningen Seaports is therefore fully committed to innovation and offers space and facilities for test centres, start-ups, scale-ups, pilot and demo plants.

Europe's biggest green hydrogen project starts in Groningen. A consortium of Gasunie, Groningen Seaports, Shell Nederland, RWE and Equinor is working on the realisation of the NorthH2 project: the production of green hydrogen using electricity generated by a gigantic offshore wind farm. The amount of green hydrogen produced, initially at Eemshaven and later possibly also offshore, is expected to be around 800,000 tonnes a year by 2040.



## H2ARVESTER

Marcel Vroom  
Meelfabriekplein 2f  
2312 LK Leiden  
The Netherlands

+31 (0)6 2246 5161  
www.h2arvester.nl  
info@h2arvester.nl



H2arvester is a circular energy system for a local and/or regional economy: local-for-local & scale-by-scale. Regional employment is leading and is in line with the concept of the 'short-chain': local producers add value to the environment and short chains help to realise the ambitions for a circular system. This is a unique opportunity to contribute to the energy transition to sustainable energy and a sustainable economy at a local and regional level, in addition to the large-scale production of energy.

H2arvester is a partnership for research, product development and realisation of movable and autonomous systems for the generation of solar energy and the production, storage and applications of electricity and hydrogen. H2arvester was founded by L'orèl Consultancy

from Groningen and npk design from Leiden. L'orèl Consultancy, npk design and LTO Noord are the inventors of the H2arvester system and have all the qualifications for energy research, technical development, facilitating pilots and outsourcing the production. H2arvester won the RVO competition 'Solar power in agricultural areas' at the end of 2017.

Selected Dutch (and preferably local) agricultural mechanisation companies are engaged for the production, installation and maintenance of the mobile solar systems. For the realisation of the electrical systems, hydrogen production and storage systems, we collaborate with system suppliers and market leaders in these industries.

## H2 Circular Fuel B.V.

Hans te Siepe  
Fabrieksweg 4  
8015 PT Zwolle  
The Netherlands

+31 (0)6 51 54 12 31  
www.h2cif.nl /  
www.h2cif.com  
hans.tesiepe@h2cif.nl



H2 Circular Fuel is a Dutch company. It has specialized in building applications to extract  $H_2$  from H2Fuel ( $NaBH_4$ ), reducing it to  $NaBO_2$  and to regenerate this Spent Fuel back to  $NaBH_4$ .

H2Fuel is a patented technology for the production, storage and release of hydrogen. For its production, no electrolysis is required. The hydrogen is stored under normal atmospheric conditions in a powder. Release takes place without additional energy, using ultrapure water. Not only is one hundred per cent of the hydrogen stored in the powder released but, as a bonus, the same amount of hydrogen is released from the water, as well.

In dry powder form, the hydrogen can be stored for an unlimited period, is in energy terms the maximum attainable result, has no safety risks and, throughout the production process from production through consumption, features no harmful emissions at all. Once the hydrogen has been issued, the residual substances can be returned to the powder state with hydrogen stored in them: this makes H2Fuel the world's first circular fuel. H2Fuel can be deployed in all sectors of society and the economy and, as a result, forms by far the preferable alternative to both fossil fuels and other sustainable alternatives.

## H2Dock BV

Denis Mulder  
Gerrit van Assendelftstraat 21  
1961 NH Heemskerk  
The Netherlands

+31 (0)6 1923 9061  
www.h2dock.com  
info@h2dock.com

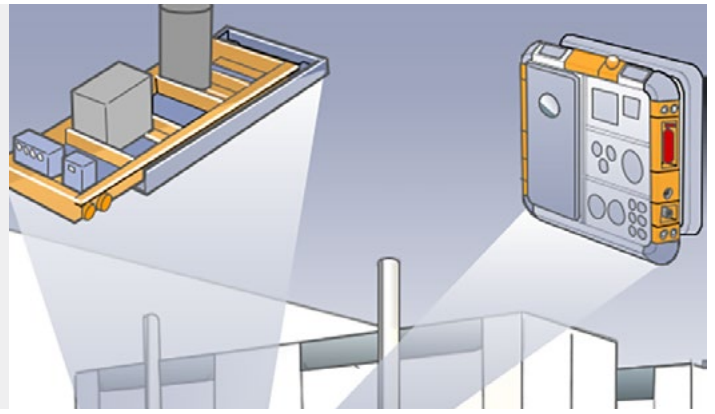

# H2Dock

H2Dock's purpose is to contribute to the energy transition by helping to lower the production cost of green hydrogen. We will enable cost effective hydrogen production by assisting our clients (electrolyser/stack OEMs & EPCs) with efficient hydrogen production enclosures, based on a standardised and modular building system. Onshore or offshore. From 5MW up to more than 1GW. Hydrogen production facilities can now be configured-to-order instead of engineered-to-order.

The H2Dock hydrogen production building system consists of three distinct parts:

- a containerized module for Stacks and Balance of Stack equipment;
- a modular plant building system for Balance of

Plant equipment and

- a docking module with interfacing connections for electrical, data/control, gas and fluids piping, facilitating the required interconnections between building blocks.

Our clients will build their equipment (Stacks, Balance of Stack and Balance of Plant) on removable skids which are placed in the containerised module or within the modular plant.

## H2Hub Twente

Ton Beune  
Kolthofsingel 8  
7602 EM Almelo  
The Netherlands

+31 (0)6 3072 1380  
www.h2hubtwente.nl  
info@h2hubtwente.nl



H2Hub Twente, officially named "Coöperatie Waardemakers in Waterstof UA", is located in Almelo. The H2Hub is a knowledge and education center and regional hub, where businesses, government and knowledge institutes come together to reshape the region towards a circular Green Hydrogen future. Starting 2024, H2Hub Twente launched a new four-year program, after successfully wrapping up "Businessplan 2020-2023" where the foundations were laid.

The new program, Roadmap 2024-2028, will focus on seven key themes relevant for the Eastern Netherlands:

- Development of Knowledge and Human Capital.
- Infrastructure and Storage.
- Mobility.
- Production of green hydrogen.
- Process, food and manufacturing industry.

- Area development.
- HORIZON (Industrial Symbiosis to Hubs for Circularity).

The H2Hub Twente owns a small scale electrolyser system that is available for experimenting and testing. Hydrogen produced on site for testing is 100% green, electricity is generated by 1MW solar and 70kW wind, which is stored in an energy storage system to ensure green hydrogen production throughout the night as well.

Partners: RES Twente, Waterschap Vechtstromen, Provincie Overijssel, University of Twente, Saxion Hogeschool, HAN, ROC van Twente, KIWA, OostNL, Boessenkool, Bolk Transport, Bolletje, Bronkhorst, Brusche, Cogas, Crematoria Twente, DEMCON, Drone4, HST Group, Hyster-Yale, Jotem, Nijwa Zero, Powerspex, Roelofs, Schröder Energie Technologie, VDL Energy Systems, Witzand



### H2Makers

Leonoor den Ottolander  
Galileistraat 33  
3029 AM Rotterdam  
The Netherlands

+31 (0)6 2139 2452  
www.h2makers.nl  
office@h2makers.nl

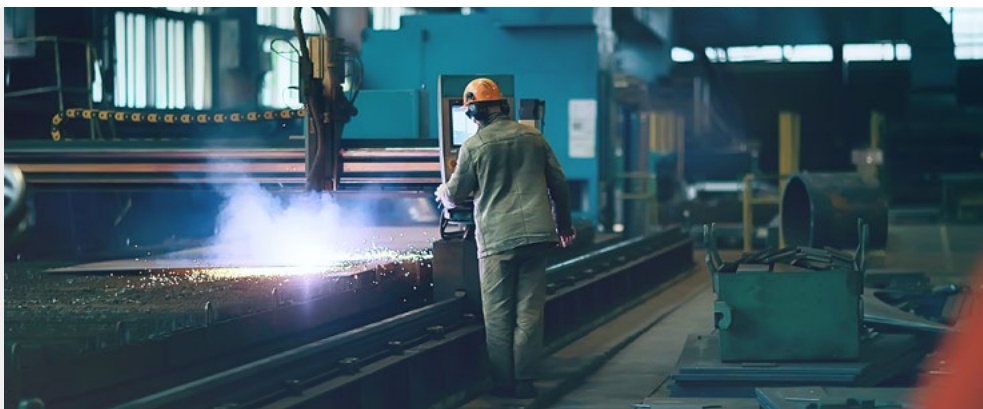

H2Makers connects the manufacturing industry for hydrogen technologies in the Netherlands. We believe in regional value chain cooperation. Therefore, H2Makers supports established manufacturing companies as well as start-ups and scale ups, to bring their hydrogen products and initiatives to life and to the market. We help organisations to find the right expertise, funding, locations, test and development centres, permits, hydrogen training, and regional collaboration partners.

The H2Makers ecosystem consists of entrepreneurs, large companies, educational institutions, regional authorities, network organisations, and experts. In example, through our Service desk we answer hydrogen related questions and follow up with the respective organisations. Furthermore, we stimulate innovation and collaboration across the value chain by organising inspiring meet-ups and challenges. We encourage organizations to invest in innovation and collaboration. This means hydrogen can benefit the industrial or chemical sector, aviation or the maritime industry.

### H<sub>2</sub>O Systems Holland B.V.

Jos M.C. Plas  
Blondeelstraat 96  
3067 VA Rotterdam  
The Netherlands

+31 (0)6 81 13 36 26  
www.h2osh.com  
info@h2osh.com



H<sub>2</sub>O Systems Holland (H<sub>2</sub>O) designs and produces systems that generate 'Warmth from Water'. Hydrogen extracted from water is widely seen as the most valuable alternative fuel. H<sub>2</sub>O introduces the 'next generation' hydrogen powered home heating systems. The system converts water into hydrogen by low power electrolysis and burn the hydrogen to produce heat.

H<sub>2</sub>O systems are designed for consumer use in single home units and in the future also available for multiple units and apartment buildings. The system is developed as an alternative for the currently used fossil fuel powered systems. The system is fully emission (CO<sub>2</sub>) free.

The system's unique points are being a 'closed system' that 'on location' and 'on demand'

generates hydrogen. Burning hydrogen makes sure the system generates energy and subsequently supplies heat for house warming and tap water.

The critical elements 'closed' and 'on location' imply no transport, no infrastructure nor any storage of gas is required. Dangerous and expensive transport and storage are completely eliminated. The key element 'on demand' implies that the H<sub>2</sub>O systems generates hydrogen 'on location' and 'on call' when the consumer turns on the system needing heat or heated tap water. This high potential research company holds the Intellectual Property (IP). Currently worldwide is no comparable system available. The Company's potential is based on international expansion as well as financial performance, shareholder and stakeholder value.

**H2Storage B.V.**

André Molengraaf  
Prinses Margrietplantsoen 33  
2595 AM The Hague  
The Netherlands

+31 (0)6 25 19 72 51  
www.h2storage.nl  
andre.molengraaf@h2storage.nl



H2Storage is a 100% Dutch company with experienced executives (from the energy, composites, aviation and automotive sectors) as the driving force behind this successful start-up. By combining our years of experience gained from the aforementioned sectors we developed a viable solution for long term energy storage. We have fulfilled an essential step towards a hydrogen economy by introducing the use of high pressure lightweight composite storage tanks from recyclable material to store hydrogen. Now we have an alternative solution to store more hydrogen under high pressure in the whole supply chain, from production all the way till the end user. This can be realized by type 4 composite cylinders with NWP of 700 bar. Portfolio of H2Storage consists of single

lightweight composite cylinders, double, triple or quadruple bundles and standard 10-45ft container containing tenfold(s) of these cylinders including the essential appendages for hydrogen storage. The solution to store locally, transport and use locally (e.g. an off-grid (emergency) generator) large quantities of hydrogen. These products are developed according to the International (ISO/ADR/ADN/TPED) and European standards (R134) for the automotive, shipping, stationary and transportation industry. Currently we are fully involved in, among other things, the SHIP2DRIVE consortium, the realization of a sustainable inland vessel and the realization of a sustainable excavator. Naturally, our role is to realize the most efficient storage and transport of hydrogen systems.

**HAN University of Applied Sciences**

HAN H2Lab frontoffice  
Ruitenberglaan 26  
6826 CC Arnhem  
The Netherlands

www.han.nl/hanh2lab  
sustainable.energy@han.nl



The HAN H2Lab is a shared R&D facility, part of the HAN University of Applied Sciences. It is a meeting place for research, education and industry and has a focus on the development, testing and validation of small and intermediate hydrogen applications as well as feasibility studies.





**Heattec Heat Technology B.V.**

Alfons Heetjans  
Spinding 30  
5431SN Cuijk  
The Netherlands

+31 (0)485 311686  
www.heattec.nl  
info@heattec.nl



Heattec is a Dutch supplier of combustion equipment, such as gas burners, biogas burners, (bio) oil burners and matching steam and hot water boilers. We are importer and service partner of the Swedish burner manufacturer Bentone for the Benelux and German market.

We supply new installations, but also execute service and maintenance on burner equipment. We also have developed a hydrogen on demand electrolyser and have made Bentone gas burners suitable for burning hydrogen.

With our burner solutions and local generation of green hydrogen with our alkaline electrolyser, we are able to make existing industrial processes more sustainable by replacing gas burners with hydrogen burners, thus reducing gas consumption and carbon footprint. We currently have hydrogen solutions starting from 100 kW installed power up to 1200 kW.

**Hinicio**

Thomas Winkel  
Boulevard Saint-Lazare 4-10  
B-1210 Brussels  
Belgium

+31 (0)6 14 53 72 04  
www.hinicio.com  
thomas.winkel@hinicio.com



Hinicio is a strategy consulting firm specialized in sustainable energy, with areas of expertise including hydrogen, renewable energies, energy storage and transport. Since 2007 Hinicio has developed a leading European competence centre on hydrogen and fuel cells. Our team collectively combines many decades of experience in the sector, including working in senior positions with leading industry players.

With offices in the EU, China and Latin America and an extensive partner network in Australia, Canada, USA, Korea, Japan, Hinicio supports customers globally on topics ranging from strategic assessments, innovation and marketing strategies, business plan appraisal, innovative business models development, market and techno-economic feasibility studies, due diligence, etc.

Hinicio has been working for players involved at every step of the value chain, from upstream (industrial gas companies, utilities, O&G companies, TSOs/DSOs), to chemical companies, equipment manufacturers (electrolysers and fuel cells), car makers and suppliers, fleet owners, public and private investors as well as industry associations and public institutions at all levels.

Over the years, Hinicio has developed world-class expertise on the development of infrastructure, a unique proprietary industry database on hydrogen and transport technologies, in-house modelling tools as well as knowledge on the (upcoming) regulatory framework.

**Hint Global B.V.**

Wolter Last  
Groteweg 61  
8191 JT Wapenveld  
The Netherlands

+ 31(0) 384 432 300  
www.hint-global.com  
wlast@hint-global.com



Hint Global helps companies with independent consulting & software tools to manage their facilities more efficiently.

Our mission is to help you avoid wasting time and money & give you the correct quality information in your hand.

Active in the following activities:

- Engineering & Consultancy
- Custom Software Solutions
- Standard Software Products

**Hobre Instruments B.V.**

Michel Eskes  
Netwerk 4  
1446WK Purmerend  
The Netherlands

+31 (0)6 5108 7337  
www.hobre.com  
m.eskes@hobre.com



At Hobré we are committed to serve our customers in achieving their goals for sustainable development. Our product portfolio has already solutions for a range of analytical challenges related to emission reduction, hydrogen, biogas, metal recycling, biofuels from waste etc.

Green hydrogen produced from solar and wind energy is increasingly mixed into natural gas grids, typical levels being up to a few percent at this moment. Projects are running that demonstrate the feasibility of bringing the hydrogen content in local gas grids up to 15% by volume. For feedforward control of gas turbines and furnaces the hydrogen content can be up to 100% and may fluctuate rapidly. The presence of hydrogen in natural gas introduces several

challenges for which Hobré offers the right solution, for example:

- Our new PRISM Raman analyzer which offers an online, zero emissions measurement of natural gas compositions, including 0-100% H<sub>2</sub>, within seconds.
- The WIM Compas on-line calorimeter can handle any mix of hydrogen (up to 100% hydrogen) and natural gas. As a result, the fast WIM Compas is a tremendous tool for feed forward control of gas turbines and furnaces that are fired on natural gas/ hydrogen mixtures.
- Participation in the Green Transport Delta Hydrogen Project to develop an online analyzer to measure hydrogen purity for e.g. fuel cell applications



**HOWDEN**

Gerald Peppelman  
Havelandseweg 8a  
6991 GS Rheden  
The Netherlands

+31 (0)26 497 52 00  
www.howden.com  
gerard.peppelman@howden.com



Howden is one of the world's leading manufacturers of air and gas handling solutions. We address the challenges of the energy transition with highly innovative solutions to contribute to the deployment of renewable and low-carbon hydrogen. Hydrogen compression is a key aspect in hydrogen applications to move hydrogen efficiently across the value chain from production to consumption. With over 100 years of experience in the compression of hydrogen, we have developed highly innovative solutions for our customers, optimising the availability, reliability and installation footprint, while reducing the total cost of ownership of operations. 'Advanced compression solutions across the hydrogen value chain' says it all. Whether gasification or electrolysis are involved, we combine innovative technology and worldwide engineering expertise across the hydrogen value chain, from the world's largest centralized operations to smaller

scale decentralized applications. Howden compression technology, based on reciprocating pistons and diaphragm compressors, enable large volumes of hydrogen and associated pressures to get the energy values needed. Howden designs and manufactures compression solutions as individually engineered packages to meet the specific demands of unique applications and requirements. Nevertheless, production and life cycle follow our established standards to meet with speed of delivery and life cycle of the compression solutions' requirements. Howden's highly innovative compression solutions can be found at the heart of leading clean hydrogen projects around the world, playing a key role in supporting the global energy transition. We have successfully supplied globally state of the art compression technologies to a large number of projects.

**HSM Offshore Energy BV**

Jaco Fleumer  
Westfranklandsedijk 9  
3115 HG Schiedam  
The Netherlands

+31 (0)6 2057 9030  
www.hsmoffshoreenergy.com  
j.fleumer@hsmoffshoreenergy.com



HSM Offshore Energy has a track record as EPCIC contractor for the upstream offshore energy sector of more than 60 years, initially having provided platform and modules for the offshore hydrocarbon sector and having pioneered in the Offshore Wind sector in 2002 with the delivery of the World's first Offshore High Voltage Offshore Substation for the Energinet Horns Rev A project.

In addition, HSM Offshore Energy are pursuing contracts for Offshore CCUS platform projects and have established a dedicated entity with engineering contractors Enersea, called H2Sea, to develop and deliver offshore green hydrogen production and compression facilities on turnkey basis.

A range of platforms with capacities from 50MW to 500MW has been developed to cater for upcoming offshore green hydrogen opportunities in the North Sea market.

Two modern construction yards in the greater Rotterdam harbour area with open North Sea access and large covered construction and assembly halls are today operated by HSM Offshore Energy.

Hy-Cell Co. Ltd.  
 Wybe Kerkhof  
 Westervoortsedijk 73  
 6827 AV Arnhem  
 The Netherlands

+31 (0)6 27 18 51 76  
 www.hy-cell.com  
 info@hy-cell.com



Hy-Cell is a fuel cell stack and system development partner, with a design team based in The Netherlands and a 20,000m<sup>2</sup> high-tech manufacturing and R&D site in China. We are specialized in the design, testing and manufacturing of heavy-duty fuel cells for trucks, trains, busses, marine and energy storage solutions. Hy-Cell can provide cell plates, fuel cell stacks, fuel cell systems and do the fuel cell system integration into your product or provide assistance for system integration. Our experience of over 15 years, plus our holistic approach enables us to make design and manufacturing decisions to minimize the Total Cost of Ownership (TCO) of your application, while guaranteeing high quality, durability and safety.

Our Design & Sales office is based in Arnhem, the Netherlands. From here we design fuel cells and serve our Western customers. Our 20,000m<sup>2</sup>

high-tech manufacturing site is located in Jinan, China. From here we develop, produce and test fuel cells and serve our Asian customers. Our design team covers all steps of the fuel cell development, allowing us to efficiently support you with the design of the cell plates, stacks and systems. Our experienced production team verifies our designs in-house and produces your high-quality fuel cells and components with state-of-the-art production and testing equipment.

Hy-Cell significantly invested in testing equipment and uses a high-end short and full stack test station up to 200 kW. The test stations, including software, are designed in-house and have extensive safety features to ensure stack and operator safety. Hy-Cell's ISO 9001 compliant plant is equipped with high-tech international test equipment.

HyCC  
 Jasper Jansen  
 Van Asch van Wijckstraat 53 F  
 (Hoek 3 building)  
 3811 LP Amersfoort  
 The Netherlands

www.hycc.com  
 contact@hycc.com



HyCC (the Hydrogen Chemistry Company), is a leading industrial partner for safe and reliable green hydrogen supplies to enable the transition to zero-carbon industry. From making sustainable steel to circular jet fuels HyCC believes that green hydrogen is the key to providing a growing population with essential products, with zero emissions to realize more sustainable economic development. Building on over 100 years of experience in electrolysis and their leadership in safety, HyCC realizes pioneering water electrolysis projects to supply industries with zero-carbon hydrogen from renewable power and water. The company's 1 gigawatt portfolio includes projects such as:

- Djewels, a 20-megawatt electrolyzer project based on advanced pressurized alkaline technology to help decarbonize industries at the Chemical Park in Delfzijl;

- H2eron, a planned 50-megawatt electrolyzer in Delfzijl to enable the production of sustainable aviation fuel and other sustainable applications at the Chemical Park Delfzijl;
- H2-Fifty, a 250-megawatt facility being developed together with bp to reduce emissions from the Rotterdam refining and chemical cluster;
- H2era, the Netherlands's first 500-megawatt green hydrogen plant, located in the port of Amsterdam;
- GreenRoot, an industrial-scale electrolysis project under development with German gas company VNG to enable the decarbonization of central German industries. HyCC B.V. is a joint venture of the European electrochemical company Nobian and Macquarie's Green Investment Group



**HyDevCo B.V.**

Bob Busser  
Wijnhaven 23  
3011 WH Rotterdam  
The Netherlands

+31 (0)6 5316 4152  
www.hydevco.eu  
bob.busser@hydevco.eu



# HYDEVCO

HyDevCo can be technology supplier, project-partner or developer for decentral hydrogen production for local use. Projects with an extraordinary environmental impact by avoiding NET 12 kg of CO2 emission for each kg of hydrogen produced. We achieve this by using the Hynoca® technology which is capable of converting RED II biomass into 5.0 quality hydrogen and biochar. We ideally place our installations on small plots, next to a petrol station, a factory or housing block where we can provide the hydrogen directly from the plant at a pressure of 8-30 bar. This way we avoid transportation costs and efficiency losses.

The hydrogen can flow directly into the process at a capacity of 30 kg of hydrogen per hour, 720 kg a day. At the production of 30 kg of hydrogen per hour, with a guaranteed availability of 8.000 hours,

the yearly need for biomass is 6.400-8.000 ton. The biomass needs to be RED II certified to obtain certified hydrogen and certified biochar. Some interesting biomass examples are, (demolition) wood, short rotation coppice, digestate from a biogas plant, (straw)manure, cereal dust, miscanthus etc. So we convert into hydrogen and biochar. The biochar meets the EBC standards meaning that it qualifies to sell related carbon certificates! At the same time the biochar, at average 1.3 ton / hectare, can be used as a soil amendment to hold water in the superficial layer, to house micro-organisms, reduce the need for fertilisers and binding nitrogen. Let's get in touch!

**Hydrasun BV**

Mitchel Pfaff  
Nikkelstraat 17a  
2984AM Ridderkerk  
The Netherlands

+31 (0)10 4049044  
www.hydrasunhgen2.com  
Netherlands.sales@hydrasun.com

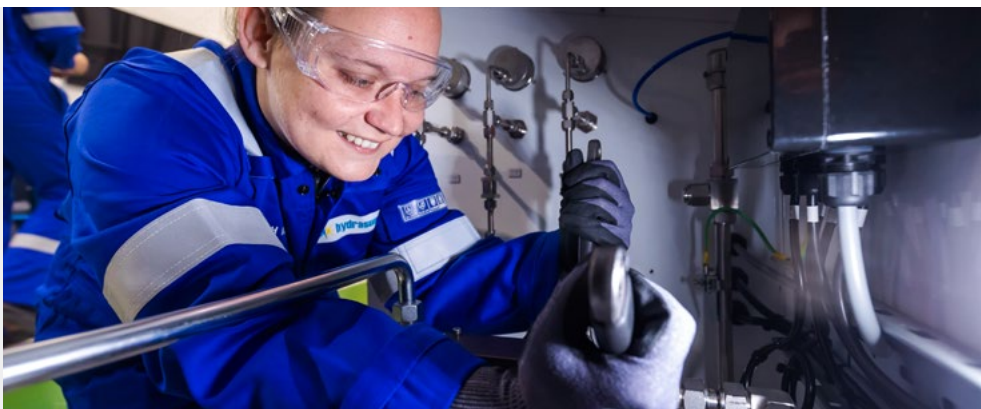

# hydrasun

Hydrasun, a leading specialist provider of integrated fluid and gas transfer solutions to the Energy Sector since 1976, has a strong track record with the successful provision of high quality, high reliability product and service offering to global markets. Hydrasun made its first moves into the emerging hydrogen market in 2016 and since then has completed a number of significant green hydrogen projects in Europe in partnership with a number of leading OEMs.

Hydrasun has developed a wide range of integrated product and service solutions for the hydrogen marketplace. This encompasses the supply of instrumentation (fittings, valves & tubing) & fluid connector products for various applications, as well as engineering support and system build. This offering is complemented by the provision of personnel to undertake site installation &

maintenance services and an overall project management capability.

Our Hydrogen Skills Academy provides training and skills development in a real world environment. We deliver a competence assessed pathway through the Energy transition by retraining and reskilling the existing workforce as well as developing a new workforce with new skills to meet growing market demands.

### Hydrogen Architects

Patrick Cnubben  
J.M. den Uylstraat 101  
9728 RJ, Groningen  
The Netherlands

+31 (0)6 4272 7045  
www.hydrogenarchitects.org  
p.cnubben@hydrogenarchitects.org



Hydrogen Architects is a specialised advisory developing Hydrogen Valleys as the vector to power energy transition and benefit (regional) economic development.

Hydrogen Architects provides services enveloping project development, liaising and matchmaking to create Hydrogen business opportunities for stakeholders from the private and/or the public sector. Hydrogen Architects brings to the table experience spanning more than 20 years in the energy, hydrogen and transition business with access to a refined network of stakeholders and partners. This body of expertise is the DNA of Hydrogen Architects' business: supporting initiation, (co)creation and (co)developing Hydrogen Valleys or Hydrogen Hubs, as it is directly and indirectly involved to many Hydrogen Valleys in Europe and therebeyond. Hydrogen Architects offers professional services operating from the heart of

the first European Hydrogen Valley over the spectrum of innovation through investments contributing to:

- Developing Hydrogen Valleys
- Developing regional Hydrogen strategies
- Developing Hydrogen ecosystems: industry, road, maritime and aviation
- Assessing Hydrogen Technologies and Hydrogen systems
- Supporting Hydrogen export/import facilities
- Connecting stakeholders and Hydrogen markets
- Connecting Hydrogen Valleys

Hydrogen Architects is your partner in the Hydrogen Arena

Connect to the future, connect to Hydrogen Valleys: connect to Hydrogen Architects!

### Hydrogen Powered Solutions BV

Frank H. Turksma  
Archimedesweg 7  
8912 AK Leeuwarden  
The Netherlands

+31 (0)58 203 03 60  
www.hydrogenpoweredsolutions.com  
info@h2ps.nl



## H<sub>2</sub>PS Hydrogen<sup>®</sup> Powered Solutions

We at Hydrogen Powered Solutions (HPS) are convinced of the possibilities of hydrogen to accelerate the achievement of the environmental targets for 2030. We offer solutions and products with hydrogen technology for financially sound conversion and sustainability of heating and combustion/incineration installations or plants. After several years of intensive R&D work, adjustment and assessment, the time has come that HPS can actively contribute to the current environmental problems. The developed hydrogen technology coupled with a combustion appliance such as a gas wall-mounted boiler or add-on burner offers a wide range of options for drastically reducing natural gas consumption and significantly minimizing the CO<sub>2</sub> emissions simultaneously. The Hydrogen Power Unit (HPU) developed for this purpose, in combination with a combustion

appliance, is capable of minimizing natural gas consumption by up to 50%.

The new technology offers a wide range of optional and on-demand operational capabilities for the HPU system to meet all requirements. The system is robust, compact, safe and requires no end-user intervention. It is fully automated and can be monitored in real time by H2PS. With remarkable and significant performance and efficiency, you can ensure that natural gas consumption is minimized by up to 50%. At present, the HPU is extensively available and finds its way into housing associations, office complexes. The HPU is committed to further developing and improving its technology to be compatible with all residential or industrial facilities with the best possible expectations.



**TU Delft Hydro Motion Team**

Sophie van 't Hoff  
Stevinweg 1  
2628 CN Delft  
The Netherlands

+31 (0)6 40 52 65 43  
www.hydromotionteam.nl  
info@hydromotionteam.nl



The TU Delft Hydro Motion Team is one of the Dream Teams at Delft University of Technology. Our team consists of 25 ambitious students from eleven different fields of study. Our team is fully committed every year to show the applications of our advanced technologies at spectacular races. For over 15 years, we have been designing, building and racing cutting-edge boats driven by sustainable tech. Each year the team builds a new boat made in conjunction with the knowledge of industry experts and the experience of alumni.

With our project we want to work together with the maritime sector to accelerate the transition to green energy. There is still a lot to be gained in this sector and by thinking together with the maritime world and innovating in the field of sustainability,

we contribute to a better and greener future. Because only together we can make a change.

This year, we optimize every part of our boat for the use of hydrogen. We will design our boat to excel in endurance, speed and manoeuvrability. To put our boat to the test, we will participate in the Offshore Competition of the Monaco Energy Boat Challenge to become world champions.

Our team shows what a multidisciplinary team of driven students can achieve with the right mindset and by combining their strengths. Being the engineers of the future, we take the next step towards a sustainable world.

**Hydron Energy**

Sander ten Hoopen  
Energieweg 15  
3771 NA Barneveld  
The Netherlands

+31 (0)34 240 31 66  
www.hydron-energy.com  
info@hydron-energy.com

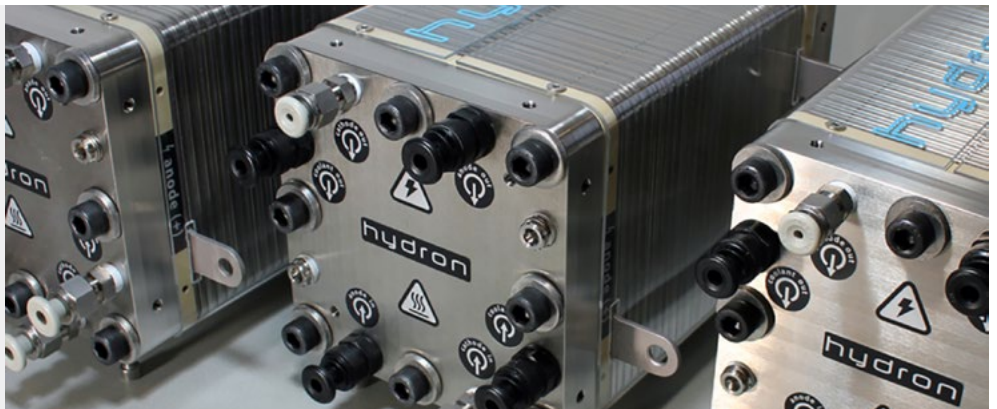

Hydron Energy is a technology innovator that develops and manufactures advanced electrolyser stacks for hydrogen production equipment.

Hydron's cutting edge Polymer Electrolyte Membrane Water Electrolyser (PEMWE) technology offers an efficient, cost effective and reliable way to produce hydrogen (and oxygen) out of water and electricity.

Our technology delivers high performance and efficiency, with an exceptional small footprint. Hydron's electrolyser stacks feature a wide operating range and excellent dynamic response, making the technology ideally suited to be coupled to intermittent renewable energy sources. Because of the application of state-of-the-art membranes, hydrogen can be produced at high pressure and purity.

The company's product portfolio consists of a range of electrolyser stack platforms that can be used in various applications: from flexible screener cells for materials development, to robust large capacity stacks for application in industrial processes.

### Hydronex B.V.

Jasper Heutinck  
Lindehof 12  
8332 VD Steenwijk  
The Netherlands

+31 (0)546 678 985  
www.hydronex.nl  
info@hydronex.nl



Hydronex is a subsidiary of the Roelofs Groep and its main activity is to initiate, develop, construct and operate energy hubs, in which green hydrogen plays a key role. We strongly believe in the growing role of local entrepreneurs and collaborations in transitioning towards a sustainable new economy, ensuring the resilience of our future energy supply.

In addition to being a developer of renewable energy projects, Hydronex collaborates with strategic partners to create decentralized energy hubs. Our hubs establish intelligent connections between the production, distribution, storage, and consumption of renewable energy, with green hydrogen often optimizing affordability, continuity, and security of supply, creating a favorable local and regional business climate.

As Hydronex, we lead project initiation, conduct technical-economic feasibility studies, manage permits, financing, stakeholders, and construction to build sustainable energy systems with our partners. Currently, we are collaborating with coalition partners on the development of the first two green hydrogen production facilities in the Dutch cities of Steenwijk (energiehubeeserwold.nl) and Vriezenveen, integrating local renewable energy sources directly into the electrolyzing process. These locations are designed to be scalable, with a potential combined production capacity of 40MW. Both installations are scheduled to be operational by the end of 2027, supplying green hydrogen for local industries and the transport sector.

### HyEnergy Consultancy (Europe) BV

Ian Williamson  
Burg. J.G. Legroweg 45A  
9761 TA Eelde  
The Netherlands

+44 7899 941422  
www.hy-energy.co.uk  
ian.williamson@hy-energy.co.uk



HyEnergy® is an experienced consultancy specialising in hydrogen and energy communities. Helping to deliver new, clean technical solutions for a sustainable future. Our goal is to ensure that the systems and technologies gain commercial acceptance by delivering low cost, clean, onsite energy solutions which compete with fossil technologies.

Beginning in the industrial gas sector, we have grown to work with many sector stakeholders – including industry, local/regional public sector organisations and national governments. Our capabilities extend across the whole hydrogen value chain, including:

- Renewable hydrogen supply, storage and distribution technologies
- Integration of electrolysis and renewable technologies
- Fuel cell and hydrogen application technologies

- Hydrogen-based integrated energy systems
- Clean energy vectors & cross-sector integration (hydrogen, renewables, biogas)
- Renewables & energy storage integration
- Microgrids & renewable-based remote/off grid power systems
- A sound understanding of barriers to market development and technology deployment in the sector
- Hydrogen Valleys
- Strategic steering of technology/product & business development
- Development of local and regional hydrogen business models
- Project management
- Collaborative project development and steering, technology evaluation
- Techno-economic analysis
- Technical & strategic due diligence
- Development of hydrogen technology & project roadmaps



### HyET Hydrogen B.V.

Maria Fennis  
Westervoortsedijk 71K  
6827 AV Arnhem  
The Netherlands

+31 (0)26 362 39 44  
www.hyethydrogen.com  
sales@hyethydrogen.com

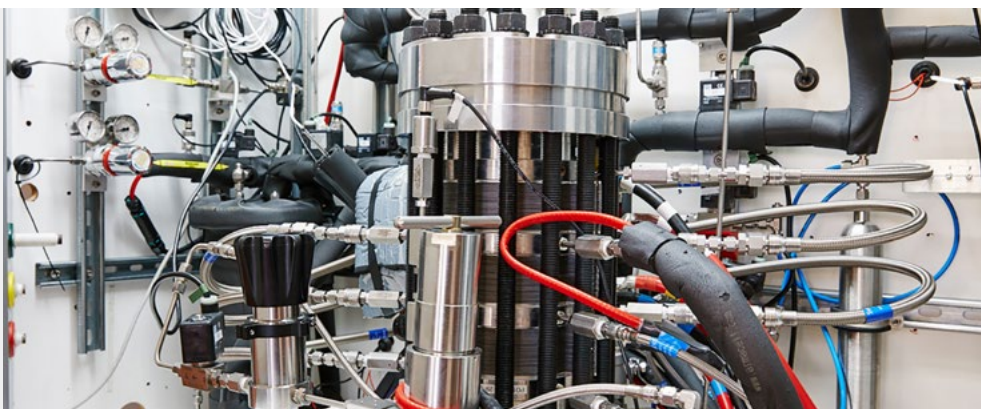

## HyET Hydrogen

HyET Hydrogen is an international company based in Arnhem, the Netherlands. HyET Hydrogen is a leading SME in the field of electrochemical hydrogen compression, extraction and separation, also referred to as Hydrogen Processing Technologies. HyET Hydrogen was founded in 2008. HyET has introduced the first commercially viable Electrochemical Hydrogen Compressor (EHC) in 2017. HyET enters partnerships with key stakeholders all over the world to develop products with a focus on application within the Hydrogen value chain. HyET's headquarters are located in Arnhem, the Netherlands and is run by an experienced interdisciplinary team. HyET Hydrogen had expanded its focus to the USA with a subsidiary, HyET Hydrogen LLC based in Colorado. HyET's Electrochemical Hydrogen Compression (EHC) is completely silent, safe, cost effective,

energy efficient and has no moving parts. The fact that the electrochemical compressor has no moving parts is also advantageous because it avoids wearing of parts which reduces the overall maintenance costs. The absence of moving parts contributes significantly to the reduction of maintenance costs and the prevention of damage, when compared to mechanical compressors. HyET's Electrochemical Hydrogen Processing technologies can significantly lower CAPEX and OPEX in the H<sub>2</sub> supply chain for many existing industrial H<sub>2</sub> markets as well as for the upcoming FCEV markets. Besides compression of Hydrogen, HyET Hydrogen also developed a technology which can extract and purify Hydrogen from mixed gas streams.

### HyGear

Henk Kleef  
Westervoortsedijk 73HG  
6827 AV Arnhem  
The Netherlands

+31 (0)88 949 43 00  
www.hygear.com  
sales@hygear.com



## HYGEAR

THE GLOBAL HYDROGEN SOURCE

HyGear, a true hydrogen pioneer since 2002, began with the conviction that on-site hydrogen production delivers unparalleled advantages in reliability, safety, durability, flexibility, and cost-effectiveness compared to central distribution. Today, HyGear has emerged as the global market leader in on-site hydrogen production, purification, and recycling, recently enhancing its portfolio with innovative carbon capture systems. Our systems utilize natural gas or biomethane for steam methane reforming (SMR) or water for electrolysis, integrating hydrogen production from biogas and carbon capture solutions to produce the most sustainable hydrogen.

As an expert partner in major international research projects, HyGear boasts exceptional laboratories, testing, and production facilities in Arnhem. We develop, manufacture, and service

on-site plants, boasting approximately 100 active HyGear installations worldwide. Our long-term clients include leading industrial organizations in the global markets for glass, metallurgy, food hydrogenation, chlor-alkali, semi-conductor, and transport.

With sales offices in The Netherlands and North America, and a production location in Poland, HyGear provides global support to its customers, supported by locally based service teams around the world. We are proudly a part of the HoSt Group, a large and rapidly growing family company established in 1991 offering high-tech renewable energy systems.

HyMatters Operations B.V. /  
 HyMatters Research & Consultancy B.V.  
 Jerom Janssen  
 Robert de Vriesstraat 19  
 6836 ML Arnhem  
 The Netherlands

+31 (0)6 25 52 04 51  
 www.hymatters.com  
 info@hymatters.com

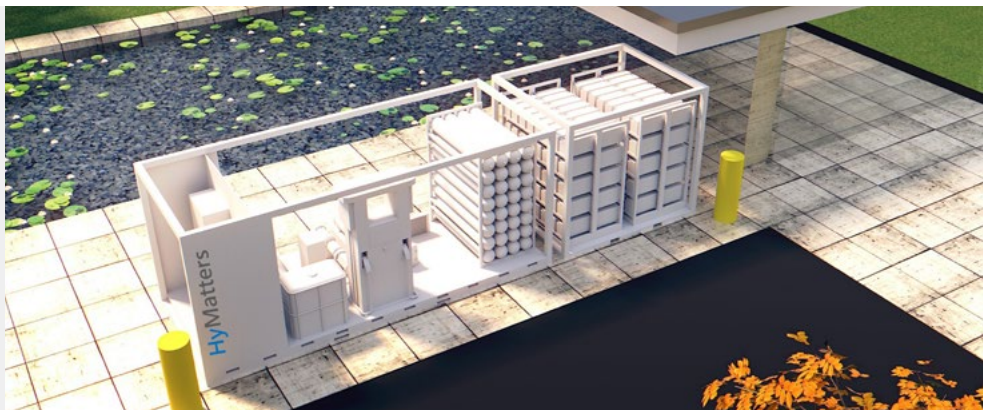

# HyMatters

Are you looking for a sustainable solution to correct a mismatch between supply and demand of energy? Or do you want to use hydrogen as a sustainable fuel? HyMatters helps you to become more sustainable with an integrated approach between energy production, energy use and grid capacity using hydrogen.

By analysing your specific situation, we will arrive at a hydrogen solution that is in line with your local energy infrastructure. We develop this complete solution for you. From concept to design, up to and including realisation.

Wondering if hydrogen is the energy solution for you? No matter where you are in the process, we can assist you. With these services we offer you customised solutions.

- Hydrogen Course
- Feasibility Study
- Engineering and Implementation
- Monitoring

HyMatters helps you achieve your sustainability goals with an integrated approach between energy production, storage, use and grid capacity using green hydrogen. We can help you achieve your goals via hardware-based, modular solutions, tailored to you needs. We can produce high quality hydrogen, but we can also stabilise your local grid while doing so. We can manage Power Quality issues, for instance through automated dynamic voltage control.

We service a wide arrange of customers like industrial clients and hospitals.

HyMove B.V.  
 T.P.M. Hendriks  
 Westervoortsedijk 73 BF  
 6827 AV Arnhem  
 The Netherlands

+31 (0)6 21 17 44 46  
 www.hymove.nl  
 info@hymove.nl

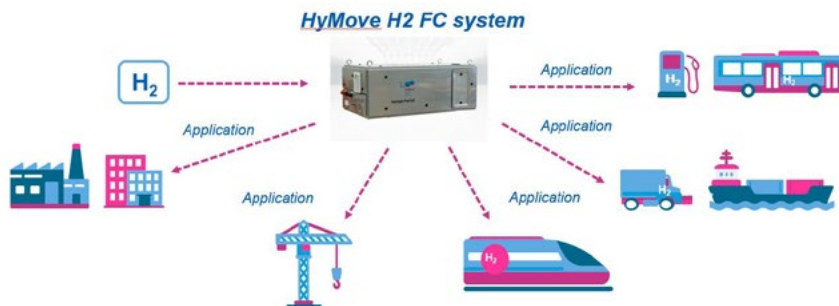

HyMove is a company, set up by inspired and experienced people. Our ambition is to contribute to a sustainable world by making clean power available in areas that are nowadays using fossil fuels, that are very polluting. We are convinced that hydrogen will be the energy carrier that allows off-grid electricity to be produced from sustainable sources. Hydrogen will be the fuel of the future.

Together with its partners HyMove offers complete solutions, such as hydrogen powered buses, vessels, construction and container handling applications.

We design and build hydrogen fuel cell systems with the highest quality, reliable and safe for a clean mobility and stationary power modules. We use our expertise to deliver valuable and innovative solutions for green hydrogen supply systems to our customers. Our responsibility is to be a partner by tailoring our solutions and services and create rewarding opportunities for our team.



### HyNorth

René Schutte  
Concourslaan 17  
9727KC Groningen  
The Netherlands

+31 (0) 50 521 24 36  
www.hynorth.nl  
info@hynorth.nl



As an independent foundation, HyNorth is committed to the development of the hydrogen investments in the Northern Netherlands. With a growing community of stakeholders, HyNorth ensures a connection between supply and demand and facilitates acceleration through a variety of means. With knowledge, research and a growing network, HyNorth is helping to build the leading position of the Northern provinces in the energy transition.

HyNorth investigates local and regional ecosystems (Hyhubs), maps out all hydrogen investment plans and informs and advises the value chain of the hydrogen economy. In addition, HyNorth makes valuable connections with local and regional government to contribute to decision-making regarding the hydrogen economy with independent and up-to-date knowledge and

information.

Since June 2022, the Good Morning HyNorth series of monthly breakfast meetings has welcomed more than 1,500 participants. With HySync meetings, HyNorth ensures the harmonization of knowledge and insight for stakeholders and with HyEnd meetings it maintains a close network with directors of companies and governments. Moreover, more and more companies are joining as HyNorth partners.

HyNorth ensures that the unique position and ambition of the three Northern Dutch provinces to be leaders in the energy transition can be translated into actions and results. The mission is: Connect to Invest!

### HyPlanet BV

Ian Williamson  
Bultinge 2  
7933 TZ Pesse  
The Netherlands

+44 7899 941422  
www.hy-energy.co.uk  
ian.williamson@hy-energy.co.uk



HyEnergy and Green Planet launched the HyPlanet joint venture as part of their activities within the HEAVENN hydrogen valley project.

HyPlanet will be developing a hydrogen trailer-filling hub in the Delfzijl chemical cluster. The hub is due to come onstream at the start of 2026.

The hydrogen, which will be obtained from the by-product of a local chlor-alkali plant, will be trailed to downstream mobility and industrial applications including the world's first inland waterway vessel to run on hydrogen-power.

## Hysolar

Jos Boere / Mr Robert Scholman  
Groningehaven 7  
3430 BB Nieuwegein  
The Netherlands

+31 (0)30 606 96 00  
www.hysolar.nl  
info@hysolar.nl



Hysolar, founded in 2019, focuses on green hydrogen for mobility. In our vision, green hydrogen is a key element in a circular economy. Relying on practical experience in combination with scientific know-how we develop green hydrogen ecosystems, where continuous innovation is crucial. Hysolar activities are threefold:

1. The supply of green hydrogen as of 2021 in Nieuwegein (NL) by opening our public 350 and 700 bar Hysolar / Greenpoint hydrogen refuelling station.
2. Using local solar power and green electricity from the grid, Hysolar realises a 2-2,5 MW electrolyser to supply 250 tons of green hydrogen starting Q2 2023. To make the electrolyser an integrated part of the energy system, it will be utilized for the dispatchable

capacity of the national grid operator. Moreover, the residual heat will be used locally to reduce the consumption of natural gas.

3. Innovation and consultancy activities to support businesses, local governments and other parties in their transition towards green hydrogen.

Over the years we have helped municipalities and businesses with our innovation and consultancy activities. We've developed solutions in which grid congestion is solved by producing green hydrogen and we work closely together with an inland shipping company to decarbonize their activities. Last but not least our innovative 'dual fuel' solution has led to the launch of the first tractor on hydrogen. We are busy applying this innovation to other heavy machinery such as excavators.

## Hystream B.V.

Joep Coenen  
Brugweg 80  
2741 KZ Waddinxveen  
The Netherlands

+31 (0)6 1114 9185  
www.hystream.nl  
info@hystream.nl

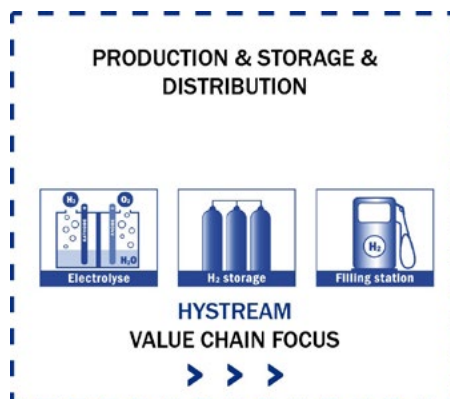

Hystream is a Dutch company, founded in 2020 with a representation in Belgium and the UK with the mission to let hydrogen flow by realizing hydrogen infrastructure. Hystream is active in the following areas:

1. Project development & management
2. Advice, Design & Permit
3. Construction & Maintenance
4. Product development

Hystream has successfully designed and built two hydrogen filling stations and is involved in various hydrogen projects as an advisor and project manager. Hystream actively develops new projects as well as products.

Hystream guides various customers with their hydrogen projects, ranging from production, filling stations to mobile power solutions. We are familiar with the most recent legislation, standards and

requirements in the field of hydrogen and have extensive experience in the Netherlands with the type of information and questions authorities can ask. We use this experience proactively to ensure that the permit processing time is as short as possible.

Based on its experience, Hystream has decided to develop two new products with the aim of broadening and accelerating the use of hydrogen:

- Compact and standardized storage of hydrogen with more effective kilos of hydrogen on board per m<sup>2</sup> and per m<sup>3</sup> compared to classic hydrogen bundles
- A highly standardized solution for industrial estates, agricultural sector and other industries with a surplus of green energy and no means to effectively convert these costs to hydrogen.



**Institute for Sustainable Process Technology (ISPT)**

Andreas ten Cate  
 Groen van Prinstererlaan 37  
 3818 JN Amersfoort  
 The Netherlands

+ 31(0) 33 7009797  
<https://ispt.eu>  
 andreas.tencate@ispt.eu



**Institute for Sustainable Process Technology**

The Institute for Sustainable Process Technology (ISPT) is dedicated to making complex industrial processes more sustainable. As an independent, non-profit organization based in the Netherlands, we connect stakeholders across sectors and disciplines in a trust-based environment, to accelerate innovation and provide a driver for the sustainability transition.

One of these programs is the Hydrohub Innovation Program, aimed at green hydrogen production through large-scale, low-cost, electrolysis-based technologies, involving over 90 partners. The program focuses on:

1. Technology: Advancing water electrolysis, exploring novel systems, and scaling manufacturing techniques
2. Scale-up: Developing strategies for cost-

effective, large-scale electrolysis, integrating renewable power sources

3. Value Chain: Analyzing global production and optimizing supply chains for efficient hydrogen distribution.
4. Deployment Enablers: Enhancing project reliability through safety, standardization, and risk assessment.

Key projects include the Hydrohub Megawatt Test Center for technology testing, Gigawatt Scale Electrolyser for system design, and HyScaling to reduce hydrogen production costs by 2030.

**Iv-Groep b.v.**

Fedor van Veen  
 Noordhoek 37  
 3351 LD Papendrecht  
 The Netherlands

+31 88-943 00 00  
<https://iv-groep.nl/en/home-en>  
 info@iv-groep.nl



Iv is active in the field of hydrogen across the entire breadth of the organisation.

Within Iv-Offshore & Energy, most of our work today is in offshore renewables, our roots are in the Oil & Gas Industry. This experience provided a solid foundation for developing offshore wind substations, both HVAC and HVDC and, more recently, hydrogen. As a result, much additional knowledge and skills have been developed to meet the challenges of these new projects: we adapted to the new offshore wind market, new operator requirements, new stakeholders, innovative technologies and broader engineering scope.

Iv-Industry is in the Hydrogen for the industrial sector., among others to provide hydrogen for efficient transport which is vital to getting green hydrogen on land and into the (small-scale) industrial sector.

Escher has developed a technology for the decentralised production of green hydrogen from ammonia. Ammonia is an excellent carrier of hydrogen that can be produced anywhere worldwide simply by extracting nitrogen from the air. Escher's technology separates the ammonia back into hydrogen and nitrogen, facilitating further separation into almost pure hydrogen and nitrogen. Producing hydrogen locally in this way costs only a fraction of the energy compared to conventional local hydrogen production with electrolysis.

We constantly seek the optimum balance between effectiveness, sustainability, and cost while never compromising on safety measures in our designs.

**Invest International B.V**  
Bart de Smet/ Itske Lulof  
Bezuidenhoutseweg 12  
2594 AV Den Haag  
The Netherlands

+31 (0)6 2339 6982  
+31 (0)6 5370 6423  
<https://investinternational.nl/>  
[info@investinternational.nl](mailto:info@investinternational.nl)



## Invest International

Invest International is a financing institution established in 2021 as a joint venture between the Dutch Ministry of Finance (holding 51%) and the Dutch development bank, FMO (holding 49%). With a financing capacity of EUR 2 billion, Invest International offers investment capital for both public and private projects, as well as grants dedicated to public infrastructure projects. Specializing in providing project financing and development expertise, Invest International plays an important role in advancing projects in emerging markets. It prioritizes leveraging this financing to generate positive impacts aligned with the Sustainable Development Goals (SDGs) while also serving Dutch interests.

Moreover, Invest International has been appointed by the Dutch government to spearhead and finance the development of green hydrogen projects in emerging markets. Additionally, it is mandated to help kickstarting green hydrogen corridors from emerging markets to Northwest Europe, as a crucial element for the decarbonisation of industries.

To fulfill this mandate, Invest International employs a diverse range of financial instruments tailored to finance initiatives of various scales, spanning from small-scale ventures to large-scale infrastructure projects encompassing the entire value chain of green hydrogen or its derivatives.

**JP Energy Systems**  
Jan Pereboom  
De Beaufortweg 11  
3711 BW Austerlitz  
The Netherlands

+31 (0)6 2058 3084  
[www.jp-energy-systems.com](http://www.jp-energy-systems.com)  
[info@jp-energiesystemen.nl](mailto:info@jp-energiesystemen.nl)



## JP ENERGIESYSTEMEN

JP Energy Systems is specialized in combined hydrogen and battery solutions and is agent of the French company Powidian. We help customers with the generation, storage and reuse of sustainably generated energy. In this way we help to make your location more sustainable and make it partially or completely energy independent. Our intelligent systems make very efficient and effective use of renewable energy sources.

JP Energy Systems is a reliable partner with many years of experience in the energy sector. We know our technologies very well and work closely together with our customers, partners and suppliers. We work with proven technologies and reliable and experienced partners who value quality. We deliver turn-key projects and provide

the complete package needed to realize the project, including project management, commissioning, service, training and aftercare.

The energy transition needs acceleration and requires new types of technical solutions and new ways of working together. We believe in having the guts to execute projects quickly and well. This not only makes the energy transition visible and tangible, but follow-up projects can be realized better and faster thanks to learnings from the experiences gained.



**Kapp Nederland B.V.**

Jeroen van Ruitenbeek  
Veerplaat 102  
3313 LJ Dordrecht  
The Netherlands

+31 (0)78 611 73 55  
www.kapp.nl  
sales@kapp.nl



**KAPP**

HEAT TRANSFER ENGINEERS

We are Kapp, Heat Transfer Engineers. We not only know every heat exchanger inside and out, but also the industry in all its diversity. In the field of heat transfer, this allows us to go further than anyone else. We design, plan, produce and construct. And we don't leave until everything works. At Kapp, we see it as our mission to accelerate the energy transition by fundamentally improving our clients' processes and projects.

When it comes to heat transfer, we really do have a head start. Like you, we are convinced that green hydrogen will make a major contribution to the energy transition. Developments in the field of hydrogen are rapid, with the number of installations and electrolysers increasing rapidly worldwide. But processes are not yet fully crystallized. Understandably so! People all over the world are looking for the optimum configuration to

produce hydrogen as sustainably and efficiently as possible. We have a suitable heat exchanger for every step in hydrogen production. This gives us a real edge, which benefits our customers. That said, knowledge and experience of other experts in the hydrogen sector are essential for us. Our approach in this market is therefore: "Here to teach, here to learn". A philosophy that stems from the realization that time is short and that we can accelerate developments, especially together with other experts from the sector.

**Kelvion B.V. - Kelvion Thermal Solutions**

Roy Niekerk  
Vlijtstraat 25  
7005 BN Doetinchem  
The Netherlands

+31 (0)6 5087 9284  
www.kts.kelvion.com  
roy.niekerk@kelvion.com



**Kelvion**



KTS (Kelvion Thermal Solutions) is a manufacturer of a wide range of heat exchangers and cooling solutions with manufacturing workshops on all continents around the globe. With their heat transfer solutions, they offer their products along the hydrogen value chain.

Examples:

- Cooling towers and industrial air fin coolers for large scale hydrogen production plants (100 MW and bigger)
- Heat dissipation for hydrogen liquefaction
- Diffusion bonded heat exchangers (also known as PCHE) for cooling high pressure hydrogen in refuelling stations
- Heat exchangers for evaporating liquid hydrogen
- Integrated solutions for heat recovery in steam methane reforming
- Recuperators in fuel cell systems

In co-creation with clients and suppliers, KTS is constantly setting new standards in the industry and creating value. As KTS has a strong track record in tailor-engineered solutions, we are always looking for new heat transfer challenges. Do you have a heat transfer challenge you would like to speak about? Contact us.



Kenter B.V.  
Dijkgraaf 2  
6921 RL Duiven  
The Netherlands

+31 (0)88 191 15 55  
www.kenter.nu  
info@kenter.nu



Kenter is a Dutch energy solutions provider, currently serving over 30,000 customers in the Netherlands. Specialized in metering services, energy infrastructure and electric vehicle charging solutions, we help organizations to optimize their energy use and adopt innovative solutions to aid the process.

As a leading energy solutions provider, we're also specialized in hydrogen metering. This can be applied in various ways and with different purposes. For example, when you want to know the exact amount of produced hydrogen.

Kenter is at the heart of today's fast-moving energy world and is ready for a challenging future. As an independent part of Alliander, we are an experienced and knowledge-intensive partner. From the local bakery to large multinationals and from sport clubs to municipalities. They can all count on the expertise of more than 300 specialists working at Kenter.

We provide a complete package of energy services and metering solutions based on an up-to-date understanding of the market and innovative technologies. Would you like to learn more? Contact us by calling +31 (0)88 191 15 55 or send an e-mail to [info@kenter.nu](mailto:info@kenter.nu).

#### Kiemt

H J van Dommele  
Postbus 5197  
6827 AW Arnhem  
The Netherlands

+31 (0)6 1148 9623  
www.kiemt.nl  
vandommele@kiemt.nl



Kiemt is a triple helix network organization located at Industriepark Kleefse Waard (IPKW) in Arnhem. As Energy Valley Bureau, Kiemt accelerates the development of innovations for energy transition and circular economy in the Eastern part of the Netherlands.

More than 200 members are participating in this active innovation network, consisting of knowledge institutions, SME's (start- and scale-ups) and (semi-)governmental organizations. These members are frontrunners in the field of energy and/or circular economy. Kiemt accelerates opportunities by scouting and screening of innovations, connecting these with the triple helix network and initiating projects and programs. By doing so, innovative, viable and sustainable products, services and companies arise from their original ideas.

Kiemt programs and organizes a regional hydrogen cluster, consisting of more than 30 SMEs (start-ups and scale-ups) and knowledge institutions. The aim of this cluster is to stimulate innovations for the further development of the East Netherlands as a hydrogen technology research & development region. This facilitates the implementation of hydrogen technology on a large scale and strengthens the regional economy at the same time.

The cluster focuses on:

- Starting up and accelerating initiatives;
- Matchmaking of parties to value chain(s);
- Exchange of knowledge and information.

**Kiwa**

Giulia Botta  
Sir Winston Churchill-laan 273  
2288 EA Rijswijk  
The Netherlands

+31 (0)88 998 35 21  
www.kiwa.com  
hydrogen@kiwa.com



Kiwa is a world-leader in Testing, Inspection and Certification (TIC), Training, Technical Advisory and Consultancy. With a background of more than 90 years in water, energy, and gaseous fuels Kiwa is a knowledge institute, and international quality authority.

Our services in the field of renewable energy production, power2X and hydrogen (low & high pressure) cover the complete value chain: Generation, Transportation, Distribution, Storage and Application of Hydrogen and Sustainable Fuels.

**Key Services:**

- Wide range of Solar and Hydrogen Testing Facilities 17025 accredited;
- Inspections of Solar, Wind, Sustainable Fuels and Hydrogen installations, including pre-compliance and consultancy inspections;
- Testing, assessment and certification of components and systems like electrolysers, fuel cells, appliances, pressurized tanks and components, pipes, valves and fittings;
- Consultancy supporting R&D programs, techno-economic feasibility studies, support in innovation and transition, technical due diligence, business and investments planning, pilots design and development, risk analyses, material research, failure analyses, etc;
- Training and qualification of personnel working in the renewable energy production and hydrogen fields.

**KLINGER The Netherlands**

Cor van der Hoek  
Nikkelstraat 2-4  
3067 GR Rotterdam  
The Netherlands

+31 (0)10 455 75 55  
www.klinger.nl  
info@klinger.nl



KLINGER is the world's leading manufacturer and provider of industrial gaskets and valves. Formed in 1886 as a family enterprise, the pioneers in gasket technology today are a globally active Group of manufacturing, sales and service companies that offer unique know-how and competent on-site consultancy services. Our know-how, which in the meantime spans more than 130 years, enables us to be fully committed to supplying not just products, but tailored state of the art sealing, fluid control and fluid monitoring solutions, using the latest design and pilot technology. KLINGER products contribute to the safety of transport, storage and processing of hydrogen. KLINGER gaskets and valves will keep the connections of constructional elements leak tight and impermeable, even for the extremely

small molecules of hydrogen. Leak tightness is essential when handling hydrogen. After all, it can ignite within seconds when coming into contact with oxygen and a spark. All KLINGER gaskets have been tested by TÜV with regards to hydrogen and are recognized as particularly high-quality seals. From the revolutionary development of the compressed fiber gasket to the advanced sealing material technology and high tech valve solutions of today, development, innovation and problem-solving abilities have always been the pillars of our philosophy. Our products are 'trusted. worldwide.' as a result of their high reliability, long life cycle and extremely low total cost of ownership.

**Koedood Marine Group**  
S. Roosjen  
Noordeinde 21  
3341 LW Hendrik-Ido-Ambacht  
The Netherlands

+31 (0)78 681 31 27  
www.koedood.nl  
hydrogen@koedood.nl



The Koedood Marine Group observes an increasing demand for electrification and sustainable inland shipping. Our group is comprised of several specialized companies centred around the development and implementation of future proof marine power trains. Koedood is the largest dealer of Mitsubishi engines in The Netherlands. With an innovative heart Koedood leads the development in the inland marine sector by example. Our group has knowledge stretching far wider than the inland marine sector alone and we are active in all markets involving maritime activities. Koedood now exists for over 40 years and has always been a driving force in the Dutch maritime industry.

Our mission is to maintain a leading role in sustainable technology for the maritime sector. With more than an decade of experience with hybrid systems and almost half a century of experience in the Dutch marine sector, our hydrogen technology can be seamlessly integrated in modern hybrid vessels. Our vision is to develop systems that can sail completely zero-emission on longer routes.

We seek strategic partners and contribute to several hydrogen projects and consortia. In the role of system integrator we take part in the Rh2ine consortium and actively develop hydrogen enabled drive train systems to further green the European waterways.

**Koninklijke Van Twist**  
Martijn Friederichs  
Keerweer 62  
3316 KA Dordrecht  
The Netherlands

+31 (0)78 632 66 44  
www.kvt.nl  
mfriederichs@kvt.nl



Royal Van Twist is a family owned business with a history of more than 180 years. 80 years ago the distributorship for Perkins Engines was acquired. Based on the strong core engine Royal Van Twist started the development for gas fuelled engines 40 years ago. This resulted in the approval as Perkins official gas partner in 2014. The current gas engine range goes from 10 to 1200 kilowatt electrical. During the 40 years of history we developed a great amount of knowledge with a large variety of gasses as Natural gas, Biogas and LPG. The last 10 years we have focused on gasses with a low methane number, mainly for thermal waste recycling processes. During these processes waste as tires, plastics, MDF and even medical waste is heated to high temperatures resulting in products like nafta (raw gasoline), carbon black, active coal and ash. As by-product a waste gas is produced. This is used as fuel for the gas generator

providing electricity to the grid). As low methane gasses could cause serious engine damage we have developed our own engine control systems. The systems are tested in our state of art in-house test facility. As hydrogen could be considered as a gas with a low methane number we asked ourselves if it would be possible to use hydrogen as a fuel for our engines. After a positive conclusion from the feasibility study during the first half of 2019 we started the technical design at the end of 2019. The design includes a custom-built hydrogen injection block which is connected to the inlet manifold of the engine. The hydrogen engine was first started in October 2020. The first pre-production engines will be available for trail applications in the first quarter of 2021. Full production will start by the end of 2021.



### Krock H2 Boats

Edo Krock  
Wilgenstraat 60  
5213 SG 's-Hertogenbosch  
The Netherlands

+31 (0)6 4879 9974  
www.krock.nl  
edo@krock.nl

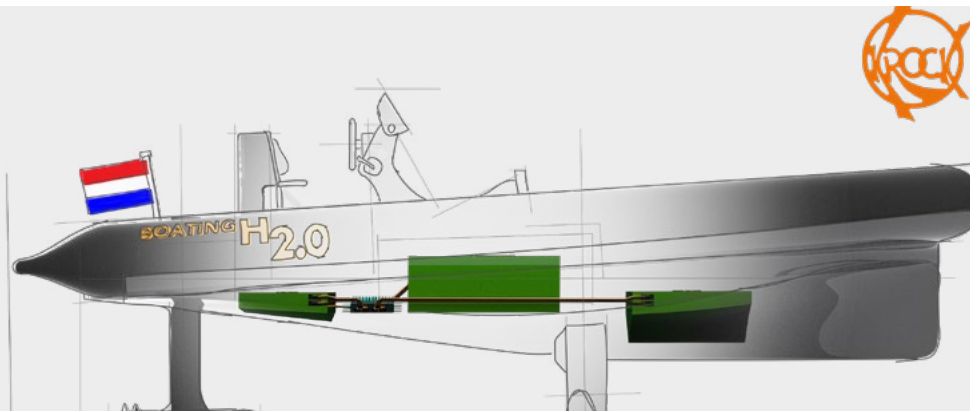

In the realm of maritime innovation, Krock H2 Boats is making waves with their groundbreaking approach to sustainable marine transportation. At the heart of their latest endeavor lies the preparation for series production of the 6-meter hydrogen-powered boat. This ambitious project marks a significant step forward in the company's mission to revolutionize the maritime industry and usher in a new era of environmentally-friendly watercraft.

Krock H2 Boats is paving the way for a greener future on the open seas. The 6-meter hydrogen-powered RHIB represents the pinnacle of efficiency and sustainability, leveraging cutting-edge hydrogen fuel cell technology to deliver zero-emission operation without compromising on performance. Designed to meet the demands

of both recreational and commercial users, this innovative vessel promises to set new standards for eco-conscious marine transportation.

In addition to their groundbreaking vessel production, Krock H2 Boats offers comprehensive maritime hydrogen consultancy services. Leveraging their expertise in hydrogen fuel systems and maritime regulations, their consultancy arm provides guidance to organizations seeking to embrace hydrogen technology in their marine operations. From feasibility studies to implementation strategies, Krock H2 Boats' consultancy services empower clients to navigate the transition towards a sustainable future.

### MAGNETO special anodes B.V.

Matti M. van Schooneveld, Ph.D.  
Calandstraat 109  
3125 BA Schiedam  
The Netherlands

+31 (0)10 262 07 88  
www.evoqua.com/en-GB/brands/  
magneto-special-anodes/  
sales@magneto.nl

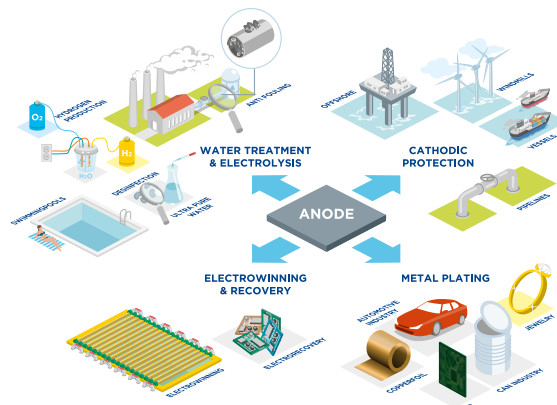

MAGNETO special anodes strives to be the best designer, producer and supplier of titanium anodes for electrochemical applications. Inventor and proud supplier of high-quality titanium anodes and electrochemical cells for a variety of applications, MAGNETO has been catering to the electrochemical industry for more than six decades. We aim to ensure our customers are satisfied with their anodes.

The right anode is key for electrochemical applications. Selecting the correct one can lead to substantial cost savings. MAGNETO understands that your application – whether it's metal plating, water treatment, electro winning, cathodic protection, or hydrogen production – has its unique features. That's why we pride ourselves on our ability to manufacture custom electrodes that

meet your requirements, regardless of the specifications. In fact, we're well known in the industry for providing the optimal anode for every individual application.

A green economy will increasingly make use of hydrogen produced by water electrolysis. It is expected that water electrolysis will play a pivotal role in the future energy landscape. MAGNETO produces several components for PEM electrolyser systems in a cost-efficient and flexible manner.

We're committed to designing, manufacturing and supplying titanium anodes for hydrogen production systems that fit your needs, withstands the test of time and reduce your operational costs.

**Magnus Energy B.V.**

Alexander van der Mark  
Gooimeer 5-39  
1411 DD, Naarden  
The Netherlands

+31 (0)88 696 60 00  
www.magnusenergy.com  
a.vdmark@magnus.nl



Magnus Energy works on a bright future. Helping to build strong energy systems that fully incorporate renewables. Balancing sustainability, security, and affordability. Navigating the complexities of the ever-evolving energy transition. We employ the best and brightest consultants with in-depth knowledge of energy markets and systems. Covering every aspect of the energy transition.

**Our cross-border hydrogen experience**

Our experts are deeply involved in the nascent hydrogen industry in Europe. Take our work for a consortium of energy companies, for example. Our experts analysed the compatibility of a cross-border hydrogen infrastructure project with the requirements of the EU's Hydrogen and Decarbonised Gas Market Package. We identified

gaps and potential red flags for the project's financing and implementation. More than that, our experts offered guidance and solutions in securing the green light for the final investment decision. *"Magnus Energy's assessment gave us the confidence that we understand the risks from regulatory changes and that all relevant aspects are addressed and under control."*

Moreover, the learnings of this project served as input for finalising the EU package. The project now serves as benchmark for future cross-border hydrogen projects. More about implementing the EU Hydrogen and Decarbonised Gas Market Package? Our experts conducted a study about its key challenges. Download the report here.

**Marsh Netherlands**

Hendrik van Duijn  
Conradstraat 18  
3013 AP Rotterdam  
The Netherlands

+31 (0)6 20 36 44 08  
www.marsh.nl  
hendrik.van-duijn@marsh.com



Marsh is a global leader in insurance broking and risk management. In more than 130 countries, our experts in every facet of risk and across industries help clients to anticipate, quantify, and more fully understand the range of risks they face. In today's increasingly uncertain global business environment, Marsh helps clients to thrive and survive.

We work with clients of all sizes to define, design, and deliver innovative solutions to better quantify and manage risk. To every client interaction we bring an unmatched combination of deep intellectual capital, industry-specific expertise, global experience, and collaboration. We offer risk management, risk consulting, insurance broking, alternative risk financing, and insurance program management services to businesses,

government entities, organizations, and individuals around the world.

Marsh JLT Specialty provides flexible project risk management and insurance placement services for the full value chain of hydrogen investments, in combination with other renewable energy sources and Carbon sequestration if required. Our service framework will enable control over risk and insurance issues and is supported by hydrogen and other renewable energy risk engineering capabilities to provide a seamless project to operational risk transfer product that will enhance bankability of your projects. The product will provide comprehensive risk protection around your planned balance sheet.

### Mechatest Sampling Solutions

André van Roon  
Koperslager 3  
2631 RK Nootdorp  
The Netherlands

+31 (0)15 310 51 83  
www.mechatest.com  
sales@mechatest.com

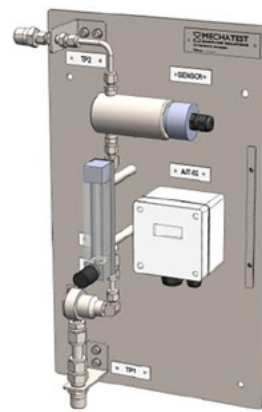

Mechatest, is a leading certified manufacturer and worldwide supplier of analyser and sampling solutions specific for the Hydrogen market but in general for the petrochemical, chemical, oil & gas, pharmaceuticals, and power industry.

We offer advice, engineering 3D design and manufacturing capability for the supply of Hydrogen measurement solutions, our solutions are suitable for outdoor use in an industrial environment and ATEX Zone 1 or 2.

Hydrogen (wet gas) analyser or detection systems should be considered for product quality control and/or protection of the environment. The major challenge in measuring hydrogen samples in wet gas in an electrolyser system is to protect the

hydrogen sensor and ensure a long service life and high-quality measurement.

The output of the electrolyser is Hydrogen and Oxygen as a gas composition and might be saturated with water vapour. To take in a wet gas a Hydrogen sample is not easy, most sensors for this typical measurement in this acceptable price range are mostly not suitable for wet gasses.

Mechatest designed for the new electrolyser unit a Hydrogen gas measurement solution that allows for analysis of the wet gas Hydrogen stream in Oxygen composition and the Oxygen in Hydrogen composition. For more information go to: [www.mechatest.com/hydrogen-measurement/](http://www.mechatest.com/hydrogen-measurement/)

### Metalot Future Energy Lab

Erik Langereis  
Randweg Zuid 34  
6021 PT Budel  
The Netherlands

+31 (0)6 15 31 11 11  
www.metalot.nl  
info@metalot.nl



Metalot Future Energy Lab aims to accelerate the energy transition by boosting the development and market introduction of promising technologies in the sustainable energy domain. Particular focus is placed on Metal Power:

the circular use of iron powder for large-scale import of renewable energy and for which H<sub>2</sub> is the key to convert rust into iron powder that can be combusted later and elsewhere.

Within the Hydrogen domain Metalot Future Energy Lab currently builds the hydrogen community in Southern Netherlands that focusses on the acceleration of experimental Hydrogen technology from TRL 4 and up, for production, storage and application. For this purpose, the Metalot H<sub>2</sub> Fieldlab has recently come available for responsible testing of small-scale hydrogen prototypes.

Together we achieve acceleration by:

- Building new value chains together with knowledge institutes, governments and companies;
- Developing joint visions and roadmaps on technology application and adoption in the market.
- Building consortia to work on concrete R&D projects to realize innovative technology and equipment.
- Joint commercialization of potential Intellectual Property.

For more information check out [www.metalot.nl](http://www.metalot.nl) or contact us via [info@metalot.nl](mailto:info@metalot.nl) to get in contact with the Hydrogen Community.



**Mokveld Valves B.V.**

Paul Kamermans  
Nijverheidsstraat 67  
2802 AJ Gouda  
The Netherlands

+31 (0)182 597 500  
www.mokveld.com  
sales@mokveld.com

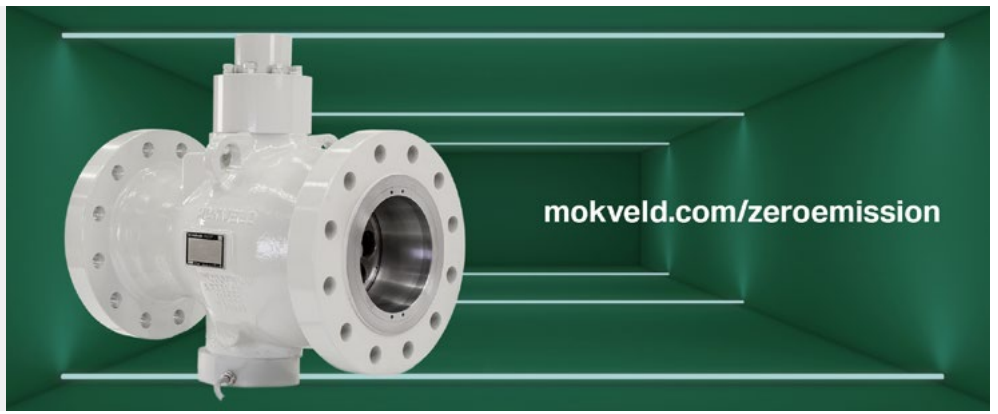

[mokveld.com/zeroemission](http://mokveld.com/zeroemission)



engineered valve systems

A future with hydrogen fits in the vision of Mokveld Valves in The Netherlands, being that the world's energy, water and material demand can be met in a sustainable way, with a responsible and environmentally safe use of our planet's resources.

Mokveld contributes to this by developing and manufacturing state-of-the-art equipment and services, based on innovative technology and best available techniques. The full scope of Mokveld valves is H2 ready.

Moreover, the latest innovation of Mokveld is highly suitable for hydrogen: a true zero emission valve! Integration of the actuator inside the valve removes the need for a dynamic stem seals thus eliminating the main potential leak path of

common valve designs with external actuators.

On top of the zero external leakage throughout the lifetime of the valve, this valve offers very low electric power requirements, extreme accuracy and our well-known axial design with the inherent streamlined flow path, high capacity and low weight. All benefits have a positive effect on the opex and on GHG emission reduction scopes allowing energy companies to achieve their net-zero goals. The valve is now fully qualified and commercially available.

Mokveld is ready to help energy companies to reduce their environmental footprint and to achieve their net-zero goals.

**Mott MacDonald BV**

Joost Bolck  
Lange Viestraat 2b  
3511 BK, Utrecht  
The Netherlands

+ 31 (0)26 3577 111  
<https://www.mottmac.com/energy/hydrogen>  
FutureEnergy@mottmac.com



Mott MacDonald is one of the largest employee-owned companies in the world and a leader in hydrogen and renewable energy. We are a global engineering, management, and development consultancy with more than 18 000 talents in 150 countries.

To reach the carbon neutrality, countries and companies around the world are increasingly turning to hydrogen as a versatile and clean energy carrier. We have the expertise to cover entire project lifecycles in the energy sector. We have been involved in more than 70 projects supporting clients to make the transition to hydrogen.

Reference Projects:

- NorthH2: We are the lead technical integration consultant for this world's largest system of offshore wind farms, transmitting power onshore to produce

green hydrogen by electrolysis.

- The North Sea wind power hub: Pre-feasibility, feasibility and pre-FEED to develop the knowledge base to help countries across Europe choose the right solution to unlock the potential of the 180GW installed offshore wind capacity by 2050.
- Energy Infrastructure Plan North Sea: guideline picture of the expected growth of the energy system in the North Sea after 2030.
- GNVL - Feasibility study of Green Hydrogen test facility. We conducted feasibility study to investigate the market needs on Green Hydrogen test facility. This covered production, import, transport, storage and utilisation to accelerate the realisation of green hydrogen economy of the Netherlands.

### MTSA Technopower B.V.

Jerome van Beek  
Westervoortsedijk 67  
6827 AT Arnhem  
The Netherlands

+31 (0)26 363 63 10  
www.mtsa.nl/lines-of-business/  
waterstof-technologie/  
info@mtsa.nl



MTSA Technopower develops decentralized energy management systems that convert green electricity into hydrogen and vice versa to make green energy available 24/7 and to prevent peak loads from solar and wind farms on the electricity grid.

Sun and wind energy is sustainable, CO<sub>2</sub> free and can be generated almost anywhere. On location, however, most of the day's yield is usually produced in just a few hours, while during the rest of the day hardly or no green power is available. Often the 80/20 rule applies.

Another obstacle to the large-scale application of solar and wind energy is the current grid capacity. This is often not sufficient to handle peak production from (planned) wind and solar parks.

MTSA Technopower offers a solution. MTSA Technopower develops product lines for:

- Power to Gas (P2G): Electrolyser systems for the production of green hydrogen in the capacity range of 1-10 MW.
- Gas to Power (G2P): Fuel cell systems for the production of electricity from hydrogen in the capacity range of 0.5-5 MW.
- Power to Power (P2P): Integrated energy management systems that combine hydrogen and electricity production.

Please visit our website: [www.mtsa.nl](http://www.mtsa.nl) or [www.mtsa.nl/lines-of-business/waterstof-technologie](http://www.mtsa.nl/lines-of-business/waterstof-technologie)

### Micro Turbine Technology B.V. (MTT)

F. Brand  
Esp 310  
5633 AE Eindhoven  
The Netherlands

+31 (0)88 688 00 17  
www.mtt-eu.com  
info@mtt-eu.com



Historic city centres and energy transition: Where heat pumps fail, and solar PV cannot be used, the Energy Transition for build environment has serious challenges to overcome. This is especially the case in Europe's historic city centres, which are essential for our European culture, identity and economy. Regulations prescribe that historic buildings must be preserved. Modern energy technologies (wall insulation, solar panels, double glazing or floor heating) are not desirable, not allowed or have severe restrictions. Heat pumps cannot be used because low-temperature floor heating will affect building structures. EnerTwin solution: The EnerTwin is the perfect solution to improve the energy efficiency and CO<sub>2</sub> emission reduction of a building. EnerTwin is a small-scale heat and power plant combined in one sustainable device. Its core is a micro turbine that drives a generator. Micro turbines have great advantages in terms of reliability and

lifetime, and bring low maintenance, high-efficiency and significant CO<sub>2</sub> emission reduction. EnerTwin is also suitable for clean fuels such as green gas, biomethane and gas mixtures with up to 23% hydrogen, but it can also run on natural gas. By using renewable fuels, 100% green electricity is produced. Moreover, this leads to additional CO<sub>2</sub> emission reductions. Plug and play installation (no renovation required) makes EnerTwin the perfect solution for rapid energy transition of historic buildings. Hydrogen: The EnerTwin is currently CE certified for fuels with up to 23% Hydrogen (mix). It will be adapted to 100% Hydrogen in 2 steps (50%, 100%), while backwards integration is still possible in case a hydrogen infrastructure is not available yet. A 50% Hydrogen solution is expected to be commercially available by the end of 2022.

### MV Energietechnik

Marcel Vogelsangs  
Albionstraat 13A  
5809 AB Leunen  
The Netherlands

+31 (0)6 28 72 46 62  
www.mv-energietechnik.nl  
info@mv-energietechnik.nl

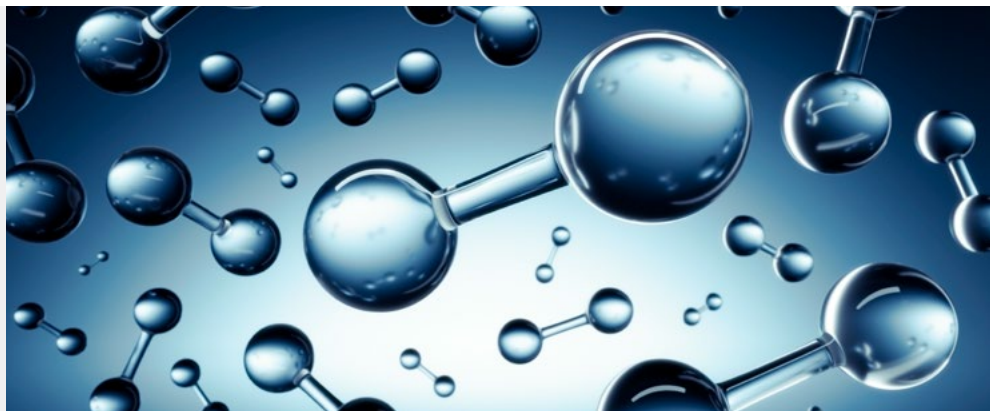

**MV Energietechnik**  
Your partner in hydrogen solutions  
www.mv-energietechnik.nl

- Concept supplier, answers for your hydrogen related questions
- Hydrogen solutions:
  - Production and conversion
  - Storage
  - Industry
  - Mobility
  - Built Environment
- Living labs – Learning by doing
- Project supervision and support
- Support and answering your inspection questions:
  - PED
  - Machinery Directive
  - ATEX
  - Low Voltage Directive
- Training and workshops

### Neptune Energy Netherlands B.V.

René van der Meer  
Pr. Beatrixlaan 5  
2595 AK The Hague  
The Netherlands

+31 (0)85 208 75 00  
www.neptuneenergy.com /  
www.poshydon.com  
info@poshydon.com /  
press@poshydon.com



**NEPTUNE**  
ENERGY

**POSHYDON**

Neptune Energy is the largest gas producer on the Dutch part of the North Sea. We are experts in producing and transporting molecules; whether those are gas or hydrogen molecules. We are moving towards a climate-neutral energy system that is reliable and affordable. The key lies in the integration of the offshore energy systems on the North Sea. It has an extensive gas infrastructure and offers opportunities for large-scale wind energy, green hydrogen production and CCS. We believe that green hydrogen is vital to the energy transition. That is why we are participating in PosHYdon, the world's first offshore green hydrogen production pilot. The pilot aims to integrate 3 energy systems in the North Sea: offshore wind, offshore gas and hydrogen by producing green hydrogen from seawater on our Q13a-A platform. The aim of the pilot is to gain experience of integrating

working energy systems at sea and the production of hydrogen in an offshore environment. "The Netherlands is in a special position as, in addition to an extensive gas infrastructure network, we can harvest large amounts of wind energy in the North Sea, quantities that are also important internationally. The wind energy can be used to generate hydrogen, which can then be transported onshore along with natural gas via existing pipelines for industry, the transport sector and for Dutch homes. PosHYdon is key to accelerating this." In February 2022 Neptune with consortium partner RWE announced the next step towards large scale green hydrogen production further off shore on the North Sea ahead of 2030: H2opZee. We aim to build 300-500MW electrolyser capacity and transport the green hydrogen via an existing pipeline to shore.



**Netherlands Enterprise Agency (RVO)**

David Koole  
Prinses Beatrixlaan 2  
2509 AC The Hague  
The Netherlands

+31 (0)70 379 80 00  
english.rvo.nl  
redesk@rvo.nl



**Netherlands Enterprise Agency**

The Netherlands Enterprise Agency stimulates entrepreneurs in sustainable, agricultural, innovative and international business. It aims to improve opportunities for entrepreneurs, strengthen their position and help them realise their international ambitions with funding, networking, know-how and compliance with laws and regulations. As a government agency, it operates under the auspices of the Ministry of Economic Affairs and Climate Policy, and its activities are commissioned by the various Dutch ministries and the European Union. The Netherlands Enterprise Agency runs a number of programmes and supports business initiatives with various grant schemes.

Energy and Climate is one of the agency's key topics. The Dutch government is investing billions of euros in energy efficiency, sustainable energy and CO<sub>2</sub> reduction. In line with this, the Netherlands Enterprise Agency supports Dutch and international entrepreneurs and researchers in developing sustainable projects related to energy, climate and the environment. Innovation and public-private partnerships are key to the Dutch approach: the government, private sector, and academia co-operate on topics such as sustainable energy technologies, green materials, built environment, sustainable mobility, chain efficiency, sustainable electricity, new gas, and greenhouses as a source of energy.

**Nettenergy B.V.**

Rob Vasbinder  
Burgemeester Colijnstraat 81  
2771GH Boskoop  
The Netherlands

+31 (0)6 4293 7974  
www.nettenergy.com  
rob.vasbinder@nettenergy.com

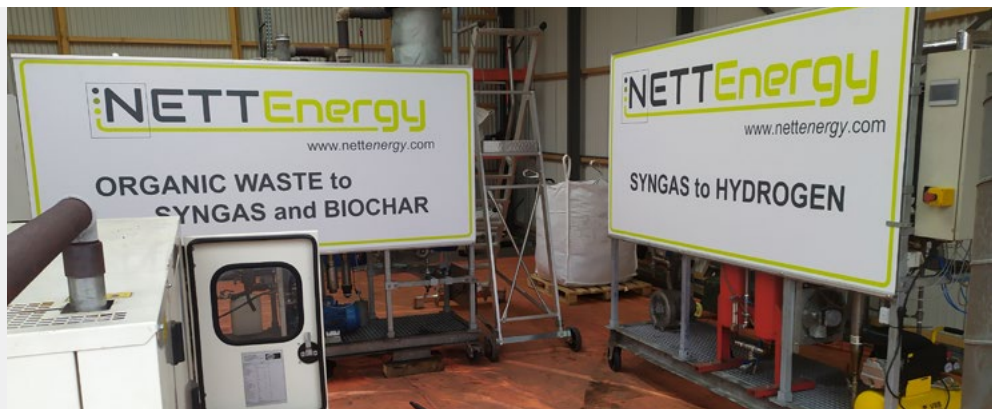

iNettenergy is a pyrolysis technology company with technology ranging from fast pyrolysis, gasification and super critical water gasification. We focus on organic waste as feedstock and small mobile installations with 10 MTPD feedstock. With our PyroGasification technology we produce syngas and biochar. This syngas can be used for electricity production or used in our unique SYN2H technology and converted into hydrogen. The SYN2H reactor is atmospheric and uses a non-catalytic process for converting the syngas. The production capacity is 500 kg/day of H<sub>2</sub>. The combination of producing renewable hydrogen and store CO<sub>2</sub> in the soil using the biochar differentiates this route from the green hydrogen produced using solar/wind. Welcome to the world of orange hydrogen production!.

**New Cosmos - BIE**

Dries Boereboom  
Maxwellstraat 7  
1704 SG Heerhugowaard  
The Netherlands

+31 (0)72 576 56 30  
www.newcosmos-europe.com  
sales@newcosmos-europe.com



For more than 65 years, New Cosmos is a leading manufacturer of cutting-edge portable and fixed gas detection equipment, driving the global transition towards New Energy. Our innovative solutions play a pivotal role in ensuring safety and efficiency during this transformative Energy Transition. Among our flagship products is the HL-310 residential hydrogen detector, designed to safeguard homes embracing hydrogen as a clean energy source. Additionally, our CSD-02 and CSD-04 hydrogen gas sensors are designed for automotive safety by providing precise hydrogen detection for fuel cell vehicles. New Cosmos also has a wide range ATEX certified gas detectors for applications such as fuel cell car hydrogen gas leak inspection, hydrogen refuelling stations and hydrogen production and storage. With a relentless commitment to innovation and

sustainability, New Cosmos is shaping the future of gas detection technology, paving the way for a safer and more sustainable world.

**Our strengths:**

With in-house sensor development, 65 years of experience, reliability, unique selectivity, long lifetime, and a wide range of gas sensors and detectors, we excel in gas detection.

**Solutions for the following markets:**

Besides New Energy Markets, we also serve markets in Oil & Gas Exploration, Chemical & Petrochemical Industry, Automotive Industry, Laboratories and the Micro Electronics Industries.

**New Energy Business School**

Nanne Bakker  
Nijenborgh 6  
9747 AG Groningen  
The Netherlands

+31 (0)6 4702 6911  
nebs@newenergycoalition.org



New Energy Business School stands as the global leader in energy education, blending theoretical foundations with practical application. We offer programs that span the entire energy value chain and address all facets of the ongoing energy transition. Our courses are made by leading academics and industry professionals, ensuring they remain at the forefront of global energy developments.

In the journey toward a zero-emission future, hydrogen is recognized for its pivotal role in the energy transition and decarbonization efforts. Serving as an efficient medium for storing and transporting renewable energy, hydrogen is key to addressing diverse energy requirements and propelling us toward a climate-neutral economy by

2050. As the sector's momentum builds, so does the demand for skilled professionals in the hydrogen industry.

Our curriculum includes a wide range of offerings, from introductory and executive courses to cutting-edge virtual reality tours, providing a deep dive into the hydrogen value chain—production, storage, transport, and use. These programs are designed to equip participants with strategic insights, practical skills, and an extensive professional network, positioning them as leaders in the energy transition.

The core mission of the New Energy Business School is the dissemination of hydrogen knowledge to foster connections among energy professionals through our network.

**New Energy Coalition**

Geerte de Jong  
Nijenborgh 6  
9747 AG Groningen  
The Netherlands

+31 (0)88 116 68 00  
www.newenergycoalition.org  
g.dejong@newenergycoalition.org



Drivers of Change

New Energy Coalition is a continuously growing network and knowledge organisation that aims for a sustainable future by accelerating the energy transition on a national and international level. A triple-helix organisation funded by public and private parties, it connects energy knowledge, policy and markets. New Energy Coalition resulted from the merger of established energy associations, creating a comprehensive coalition of research and educational institutes, leading energy companies and government parties.

The coalition focuses mainly on the development and valorisation of growth potential of the energy sector in the Dutch provinces of Groningen, Friesland, Drenthe and Noord-Holland, the region being a perfect breeding and testing ground for energy innovation. The accumulated knowledge

and results are available for the benefit of all.

New Energy Coalition is the catalyst of the Northern Netherlands' Hydrogen Valley (as well as recently Noord-Holland Hydrogen Valley), a six-year European programme in which more than thirty public and private parties contribute to the realisation of a hydrogen network and value chain. From large-scale production of hydrogen up to expansion of the number of hydrogen vehicles and fuelling stations, and from underground hydrogen storage to heating of residential areas. All these initiatives are being developed within the Hydrogen Valley ([www.newenergycoalition.org/en/hydrogen-valley/](http://www.newenergycoalition.org/en/hydrogen-valley/)), which has put the region on the international map as the exemplary region for hydrogen.

**Nexus Energy B.V.**

Lars Lamet  
Parallelweg 8  
2921 LE Krimpen aan den IJssel  
The Netherlands

+31(0)6 5104 2003  
www.nexusenergy.nl  
lars.lamet@nexusenergy.nl



We started Nexus Energy because we felt a strong sense of responsibility to change our beloved maritime and transport market for the better. We have to eliminate the use of fossil fuels. It's that simple. This has been the core of our developments. In addition, we felt that the energy transition shouldn't feel imposed change... it should feel like improvement.

And improvement only comes when things are Easier, Better and more Fun. This is the basis of all our decision making in the development of our company.

We start with our mission by providing a hydrogen powerpack for the maritime, infra & construction and aviation markets. We have a focus on high consuming equipment, such as workboats, cranes, piling rigs and airport GPU's.

What makes us unique is the compactness of our system: our powerpack has the highest energy density around. Together with a tailor made and in-house designed control system, we provide your electricity extremely efficient. Not only does our powerpack allow you to work 100% zero emission, but due to the high energy efficiency it also results in substantial fuel cost savings.



**Noordgastransport B.V.**

Ron Hagen  
Prinses Beatrixlaan 5  
2595 AK Den Haag  
The Netherlands

+31 852 087 501  
<https://noordgastransport.nl>  
[ron.hagen@noordgastransport.nl](mailto:ron.hagen@noordgastransport.nl)

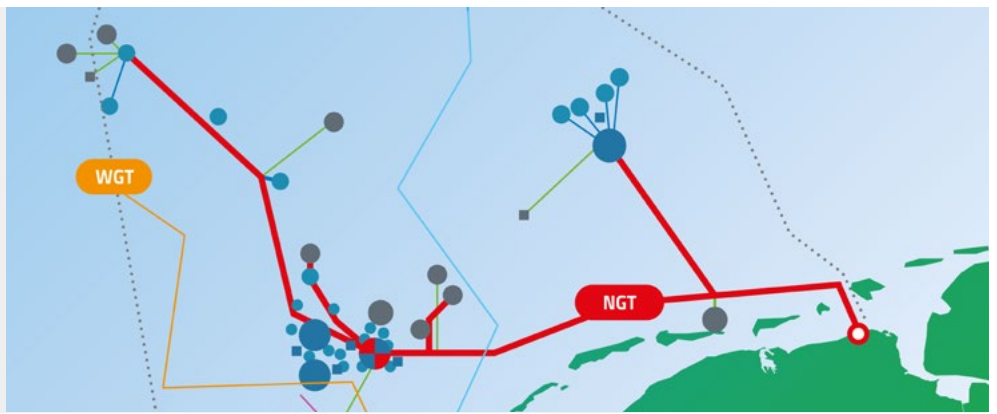

NGT B.V. owns and operates a nearly 500 kilometer network of pipelines in the North Sea. For over 50 years we have been successfully transporting natural gas to shore. By transforming the existing infrastructure into an integrated offshore hydrogen backbone, we aim to accelerate the green hydrogen economy.

Integrating existing infrastructure is the smart way forward. We join relevant consortia and projects to share knowledge and expertise. Among others, we are member of the European Clean Hydrogen Alliance and consortium partner in PosHYdon. NGT brings energy ashore.

With natural gas production declining and a new sustainable energy generation growing we aim to reuse our existing pipelines to transport offshore produced green hydrogen to land. Research results show that our extensive gas pipeline infrastructure – running from the North Sea UK border to Uithuizen, Groningen – is suitable to transport hydrogen. Furthermore, combined with the equally suited NOGAT pipelines- running from Denmark to Den Helder- we can start transporting H2 as early as 2030 and ensure a redundant offshore pipeline system by 2045.

**Development Agency North Holland North (NHN).**

Robin van Beijnum  
Bergerweg 200  
1817 MN Alkmaar  
The Netherlands

+31 (0)6 21 94 51 32  
<https://investinnhn.com/energy/waterstof/>  
[rvanbeijnum@nhn.nl](mailto:rvanbeijnum@nhn.nl)



The Development Agency Noord-Holland Noord (NHN) plays a significant role in the development of the hydrogen economy in the region 'Noord-Holland Noord', located above Amsterdam. NHN is actively involved in promoting the development of sustainable energy solutions, with a focus on hydrogen. Together with a network of stakeholders, including companies, universities, and research institutions, NHN supports the development and implementation of hydrogen technology and infrastructure, such as fueling stations. NHN also assists companies interested in investing in hydrogen technology in the region.

processing, storage and transport of energy and the large-scale plans for more sustainable energy, puts the NHN region on the map as hydrogen region of the Netherlands. Together with local and foreign companies, research institutes such as the Faraday Laboratory of TNO in Petten, and operation and maintenance facilities at the Port of Den Helder, we work on the energy for our future, which is expected to include Hydrogen production at the North Sea in combination with the onshore hydrogen production initiative H2-Gateway.

Furthermore, NHN promotes the region as an attractive location for companies involved in the hydrogen value chain. The existing infrastructure of on- and offshore gas and oil pipelines, our experience and knowledge with the generation,

NHN aims to accelerate the growth of the hydrogen economy in our region and beyond for a sustainable energy future.

## NLHydrogen

Alice Krekt / Samira Farahani  
Weena 505  
3013 AL Rotterdam  
The Netherlands

+31 010-800 15 88  
www.nlhydrogen.nl  
alice.krekt@nlhydrogen.nl /  
samira.farahani@nlhydrogen.nl



NLHydrogen is the industry association that connects, strengthens, and represents the hydrogen sector in the Netherlands. Together with our members we lead the way in the realization of a CO<sub>2</sub>-free society. With knowledge sharing, a powerful network, and sustainable solutions, we ensure that our members are and remain frontrunners. Our goals are

1. Improving the investment climate for the hydrogen value chain by

- Stimulating the use/purchase of hydrogen.
- stimulating the supply of renewable and low-carbon hydrogen from various sources.
- Facilitating the construction of hydrogen infrastructure, emphasizing a systems perspective and cross-border connections.

2. Utilizing hydrogen in a socially responsible manner by

- Ensuring the safety of hydrogen production,

use, and transport through collaboration with the Hydrogen Safety Community.

- Implementing specific measures with partners and members to adhere to the ICSR covenant.
3. Being an important spokesperson for policy development in the Netherlands by
- Offering fact-based information and innovative solutions to support hydrogen policy making in the Netherlands
  - Assisting both members and the government in implementing EU hydrogen regulations within the country.
  - Connecting our members with other hydrogen players at international level, through our strong relationship with other European and international hydrogen associations.

Our moto: Hydrogen connects today with tomorrow

## NOGAT B.V.

Hans Janssen  
Pr. Beatrixlaan 5  
2595 AK The Hague  
The Netherlands

+31 (0)85 208 76 00  
www.nogat.nl  
hans.janssen@neptuneenergy.com



NOGAT BV is the owner and operator of a 250 kilometre offshore pipeline system connecting Danish, German and Dutch natural gas fields with the onshore Dutch network with a daily capacity of 36 million Nm<sup>3</sup>. With declining natural gas production, NOGAT is working on a new business model to accommodate large scale offshore green hydrogen production. The NOGAT system has the capacity to transport approximately 10

-12 GW of wind power in the form of green hydrogen. A pilot project bringing together offshore wind, hydrogen production and transportation is being prepared at one of the connected platforms and is expected to be on stream in 2026. NOGAT is member of the European Clean Hydrogen Alliance and consortium partner in PosHYdon, H2opZee, North Sea Energy Program 4 and PHD@Sea.

### North Sea Port

Daan Schalck  
Schelpenpad 2  
4531 PD Terneuzen  
The Netherlands

+31 (0)115 647 700  
www.northseaport.com  
port@northseaport.com



North Sea Port is taking a lead in the energy and climate transition and playing the hydrogen card. As one of the Europe's ten largest ports and one of the top industrial regions of Western Europe, North Sea Port is in an excellent position to secure a leading role in the production, storage, transit and distribution of green hydrogen as a sustainable energy source and circular raw material. The cross-border port area is already the largest hydrogen cluster within the Benelux countries, producing and consuming 580,000 tonnes of the gas every year. The unique combination of the steel and chemicals industries and the presence of large solar and on/offshore wind farms enable interactions between major players committed to greening and sustainability who are using hydrogen as a lever to that end. Several projects to build electrolyzers and installations to convert hydrogen into synthetic

fuels and raw materials are at the construction stage and will be operational in the near future. In many cases, these are 'first of their size' projects. North Sea Port and its partners are also further developing the necessary basic pipeline infrastructure to link together supply and demand. They are working towards a marketplace for hydrogen as an indispensable link in a value chain extending beyond the port area. In addition, the port is releasing more than 400 hectares for investments that will reinforce this circular dynamic and pave the way for sustainable economic growth and jobs. The strategy and aims of North Sea Port are in line with the objective shared by Europe, the Netherlands, Belgium and Flanders of a climate-neutral and zero-emission future.

### Nuvera Fuel Cells Europe

Santiago Bresani  
Nijverheidsweg 34  
6541 CM Nijmegen  
The Netherlands

+49 173 7458581  
www.nuvera.com  
sbresani@nuvera.com



Nuvera Fuel Cells Europe (NFCE) is a division of Nuvera Fuel Cells, LLC, a global provider of efficient and reliable zero-emission power systems for on- and off-road vehicles, port equipment, stationary power and maritime applications. Nuvera® Fuel Cell Engines power numerous motive and stationary applications worldwide. Our customers leverage Nuvera's three decades of technology development and field experience proven in real-world operation.

lastly a customer focused office is deployed to support our customers in the Business Development, Application Development, and Aftersales phases.

NFCE, based in Italy and the Netherlands, provides engineering and application services related to fuel cell system design and development. Nuvera operates a testing, qualification, and service facility for assuring the durability and reliability of Nuvera fuel cell products and components. And



**Netherlands Hydrogen & Fuel Cell Association NWBA**

Arjan de Putter  
P.O. Box 1533  
9701 BM Groningen  
The Netherlands

+31 (0)6 51 45 20 34  
www.nwba.nl  
info@nwba.nl



The Dutch Hydrogen Association (NWBA), founded in 2002, has a noble goal in mind: the promotion of hydrogen and fuel cell technology in the Netherlands to make our society more sustainable. As the beating heart of the Dutch ecosystem for the hydrogen market, we bring together crucial stakeholders, including companies, governments, universities and international partners.

With more than 75 active members, the NWBA acts as the gateway to the national hydrogen cluster. We regularly organize knowledge sessions and networking events where interesting parties come together. Our members can access projects, share expertise and seek advice within our WhatsApp communities.

Thanks to the strength of our members and our extensive network, we strive to make the Dutch

hydrogen market more competitive and accessible. Furthermore, we represent the Netherlands towards important international stakeholders.

**Pillars**

To stimulate the use of hydrogen and fuel cell technology in the Netherlands, the NWBA has organized itself into three pillars:

- Government & International
- Human Capital Agenda
- Innovation, Knowledge Exchange & Stimulation of End Use

Based on these pillars, the NWBA develops its initiatives to stimulate the hydrogen and fuel cell market in the Netherlands. We regularly form new working groups within these pillars and we also have young NWBA, the first Dutch hydrogen organization for students and Young Professionals

**NXT Mobility**

Erik Metselaar  
Vennewatersweg 2b  
1852 PT Heiloo  
The Netherlands

+31 (0)88 472 04 72  
www.nxtmobility.nl  
info@nxtmobility.nl



Due to environmental and climate challenges, the demand for more sustainable mobility is growing. There are good alternatives to petrol and diesel available, but the availability of these alternatives is not yet optimal. NXT Mobility is a total concept to make mobility more sustainable. We offer climate-neutral mobility cards and charging solutions for electric vehicles. With NXT Energy Hubs, our filling stations of the future, we already offer less environmentally and climate-damaging fuels and

energy solutions. We increase the availability of more sustainable fuels and make the energy transition locally possible. In addition to traditional fuels, we offer more sustainable variants at our NXT Energy Hubs such as LNG, HVO, electricity and hydrogen. The first hydrogen filling point will be realised mid 2022 at our NXT Energy Hub in Alkmaar. The second will be opened at the end of 2023 at our NXT station in Westzaan.

### OCI Global

Sjoerd Jenneskens and Just Hasselaar  
OCI Global, Poststraat 1  
6135 KR Sittard  
The Netherlands

oci-global.com  
sjoerd.jenneskens@oci-global.com



OCI Global is a leading global producer and distributor of nitrogen, methanol, and hydrogen products and solutions providing fertilizers, fuels, and feedstock to agricultural, transportation, and industrial customers around the world. OCI's global production capacity spans four continents and comprises 16.7 million metric tons per year. OCI has more than 4,000 employees and is headquartered in the Netherlands.

Key hydrogen projects in development include:

- A world-scale blue ammonia plant in Texas, with low carbon hydrogen and nitrogen supplied by Linde, which is on track to start production in 2025. It will be the first greenfield blue ammonia facility of this scale to come onstream in the United States.
- Our green ammonia project, Egypt Green Hydrogen, Africa's first integrated green

hydrogen plant, started commissioning its first unit of 15 MW in November 2022.

- Landmark collaboration with Masdar and ENGIE to study the co-development of a green hydrogen facility in the UAE.
- Expansion of ammonia throughput capacity in the Port of Rotterdam, and a partnership with North2 that will see the development of the first large-scale green ammonia and methanol value chains in the Netherlands.
- Evaluating a gasification opportunity at our methanol facility in the Netherlands. This would be the first plant in the Netherlands to transform biomass derived feedstocks into bio-methanol to cater to growing demand in the marine and vehicle fuels markets and the chemicals market.

### ON2Quest

Roy van Oevelen  
Wiekenweg 44A  
3814AG Amersfoort  
The Netherlands

+31 33 888 1224  
www.on2quest.com  
info@on2quest.com



ON2Quest is a global supplier of advanced gas generation and purification technologies, catering to industries requiring reliable, cost-effective, and environmentally friendly systems. The company's key business activities encompass the engineering, supply, and maintenance of hydrogen, nitrogen, and oxygen generation and purification systems. With a focus on innovation and sustainability, ON2Quest aims to provide cutting-edge technologies that meet the evolving needs of its customers worldwide, ensuring efficient solutions across various sectors.

As every project is unique and every gas stream is unique we have a portfolio of purification technologies available at ON2Quest. Together with the customer and our engineering team we will jointly determine the best purification technologies for each individual scenario. Where customized systems typically result in high capital expenditure for the end-user ON2Quest can limit this due to the

use of standardized components and technologies.

Amongst other ON2Quest offers hydrogen purification via PSA technology, for the PSA we have a portfolio of technologies varying from the use of rotating manifolds to the use of VPSA for increased yields at lower pressures. Other purification techniques include the targeted removal of oxygen by use of catalytic conversion and if required, a TSA to remove the water from the product gas. To enable reduction of harmful emissions as soon as possible ON2Quest also offers gas recycling systems. At ON2Quest we have the strong belief that recycling of industrial gases is possible in many industries and is the most efficient way to reduction of harmful emissions.

Are you in need of gas purification or recycling, please contact us and our specialists will gladly help you out!

### Pondera (Consult B.V.)

Dennis Geutjes  
Amsterdamseweg 13  
6814 CM Arnhem  
The Netherlands

+31 (0)6 2736 1251  
www.ponderaconsult.com  
d.geutjes@ponderaconsult.com



At Pondera, we understand the complex environmental challenges that governments and companies face. As consultants and developers of sustainable energy we use our knowledge and expertise to aid in diverse energy-transition projects that contribute to a greener future.

We have in depth knowledge and expertise in every step of the project development process, from conceptualization to hand-over across a multitude of renewable energy implementations, including hydrogen. Our services cover permitting, contracting, feasibility studies, market studies, owner's engineering, project management, modelling, due diligence, technical auditing and risk assessment related to the production, storage and transport of (RFNBO-grade) hydrogen.

We have applied this knowledge and expertise to advance the development of hydrogen infrastructure in the Netherlands and internationally. Our active projects include, for example, the permitting, contracting and owner's engineering of the development of a 10 MW offshore hydrogen production platform, contracting of 50 MW onshore hydrogen production, modelling of hydrogen chains, and the permitting of large-scale offshore hydrogen transmission infrastructure.

We are always pursuing innovative projects that further the energy transition and would gladly get into contact about your project.

### Port of Amsterdam

Maurice Delattre  
De Ruijterkade 7  
1000 GK Amsterdam  
The Netherlands

+31 (0)6 3927 1782  
www.portofamsterdam.com  
maurice.delattre@portofamsterdam.com

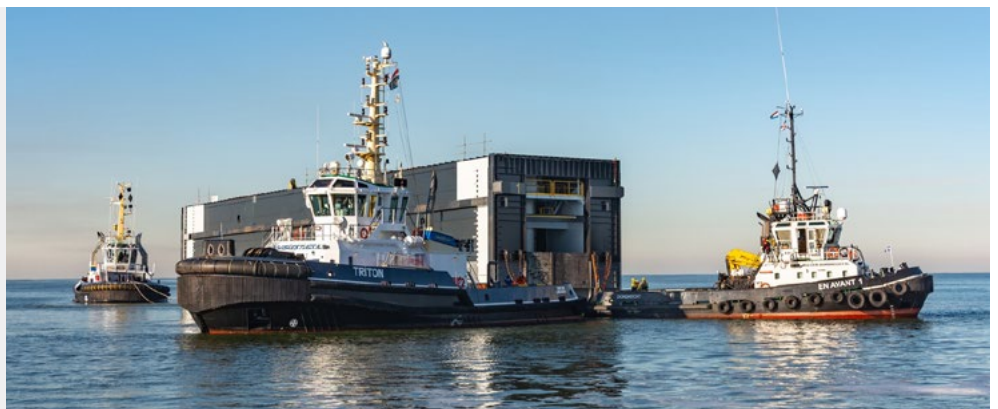

The Port of Amsterdam is currently one of the leading energy hubs in Europe with availability of large scale flexible tank storage terminals, supported by extensive blending infrastructure for oil products, and its role as a supplier of kerosene to Schiphol Airport through a direct pipeline. The Port of Amsterdam is however strongly committed to play an active role in the transition towards sustainable energy production and use in both local, regional, national and international supply chains. The Port of Amsterdam therefore aims to become the largest hub for the storage, blending and transit of renewable and synthetic fuels in Europe. In addition, it enhances the investment climate for existing and new companies to establish production facilities for these types of fuels.

The port is working closely with different partners

to establish new value chains based on for example hydrogen, synthetic kerosene, and methanol. Therefore the proposal presented by the Port of Amsterdam reflects the strategy of the port in the development of creating the 'building blocks' for the Future Fuels Hub containing the following clusters of projects:

#### Infrastructure projects

- Regional Integrated Backbone (RIB): development of a newly constructed regional hydrogen pipeline connecting production sites (e.g. project Hermes / 100 MW electrolysis with Nouryon and Tata Steel) as well as the national hydrogen backbone, with partner Gasunie.
- Development of a hydrogen distribution network in the port area.
- Development of a (green) CO<sub>2</sub> distribution network in the port.



### Port of Rotterdam

Randolf Weterings / Mandy Ros  
World Port Center (WPC)  
Wilhelminakade 909  
The Netherlands

+31 (0)6 2029 3641 / +31 (0)6 1134 7932  
www.portofrotterdam.com  
rfm.weterings@portofrotterdam.com /  
mj.ros@portofrotterdam.com



Rotterdam is the largest energy hub in Europe and is a frontrunner in the energy transition. Hydrogen is a key element in this transition. Together with its partners, the Port of Rotterdam is working on a series of projects to develop the production, use, infrastructure, import and transit of hydrogen for both blue and green hydrogen. Regarding green hydrogen, several companies are making plans to ensure that an electrolysis capacity of 500 MW will be operational by 2026. This capacity could be scaled up to 2 GW by 2030, among other things by realising 2 GW of additional wind at sea, connected to Rotterdam. For the exchange of hydrogen between companies, there will be a hydrogen pipeline through the port area in 2025, where the construction of the national hydrogen backbone starts. This is a boost for the development of a physical hydrogen market, and so is the realization of a hydrogen exchange.

Together with a large number of partners, the Port of Rotterdam is examining the import and transit of hydrogen from overseas, to replace the current European fossil energy imports (like oil, coal). This is done with parties from many countries, ranging from Iceland to Australia and from the Middle East to South America. To be able to accommodate these imports, the focus is on realizing terminal facilities in Rotterdam and a robust infrastructure to the hinterland, especially hydrogen pipelines to Chemelot and North Rhine-Westphalia. Simultaneously, the application of hydrogen is encouraged, as fuel for industry and the transport sector, and as raw material for chemical products. Current projects include one that is aimed at having 1,000 hydrogen-powered trucks on the road between Rotterdam, North Rhine-Westphalia and Antwerp, and projects on the use of hydrogen as a fuel for inland shipping.

### Power2X

Lisette Bitter  
Tolstraat 201  
1074 VJ Amsterdam  
The Netherlands

+31 (0)22 94 60 67  
www.power2x.com/  
info@power2x.com



Power2X is a project developer and management consultancy for energy transition projects across Europe and North America. The company works with several business partners on new projects in the energy transition. The focus is on sizeable projects in Green and Blue Hydrogen as well as related conversion, storage and end use assets, all with a focus on decarbonization of industry. This also includes projects related to green ammonia, methanol and other derivatives, such as clean fuels. Power2X has a growing team of circa 50 professionals and is headquartered in Amsterdam, the Netherlands. It has a development pipeline of 5 large scale projects, in various stages of development.

energy intense assets. In case of a project owner involvement, we look after projects with a CapEx ticket of €250+ million. The current project development pipeline includes:

- Blue and green hydrogen
- Renewable ammonia production (e.g., the Power2XMadoqua project)
- Bio- & e-methanol
- Other derivatives like SAF and rDME

Supported projects often imply large-scale greenfield projects, major industrial site redevelopments, and decarbonization of large

**Pro Control Process Automation B.V.**

Ger Bloem  
MC v Voordenstraat 5  
1483 GB De Rijp  
The Netherlands

+31 (0)299 630 690  
www.pro-control.nl  
info@pro-control.nl



Pro Control is an engineering company with a very clear focus on the delivery of process control (PLC controls) and data acquisition systems for process installations (lab, bench and pilot scale) and skids. We have been doing this for over 20 years and work for well-known organizations active in the world of Chemicals, Oil & Gas, Seed Breeding, Aerospace and Defence.

We distinguish ourselves through our knowledge and expertise of measurement & control technology applied in these demanding and often complex environments. We have knowledge of Siemens, Eurotherm, Honeywell, DeltaV, Rockwell, Beckhoff, Hitachi, Wonderware, iFix, Reliance and National Instruments LabVIEW (we are NI Alliance Partner).

Supplemented with our expertise in the field of measurement and control technology, integration of analytical instrumentation (GC, MS, FTIR, etc.),

recipe control, data processing and the fact that we can deliver E&I projects turn-key, makes us a serious discussion partner in the field of automation and control engineering.

To give you some examples:

- For several skid builders active in Petro Chemical environments we are supplying the automation for the process skids they developed. Units have spread all over the world;
- We are an automation partner for a seed breeder in Enkhuizen and we supply turn-key machine controls and carry out extensions/adjustments/renovations to the automation of existing installations;
- For the space authority we supply the automation (software, cabinet, cabling) of a vacuum set-up in which materials are tested in extreme conditions.

**Prodrive Technologies B.V.**

Wouter van Gennip  
Science Park Eindhoven 5501  
5692EM Son  
The Netherlands

+31 (0)40 2676200  
www.prodrive-technologies.com  
wouter.van.gennip@prodrive-technologies.com

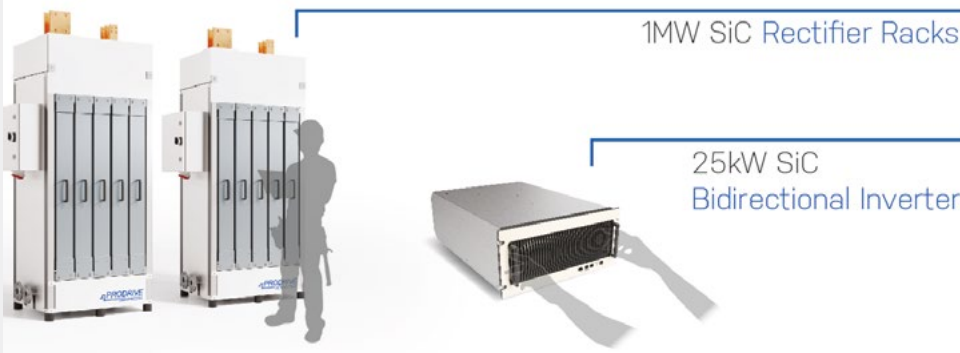

Building on over 30 years of experience in high-reliability and high-precision power electronics, Prodrive develops two SiC-based power conversion solutions for both efficient and scalable hydrogen production (electrolysis) and hydrogen consumption (fuel cells).

For hydrogen production, a 200kW module is designed for a rectifier to be scalable to GW-scale while being significantly more efficient, compact, and reliable compared to contemporary thyristor and IGBT technology. The use of SiC-based power electronics also allows for a flexible output voltage (0 – 1500V), and an almost negligible disturbance on the grid provides unlimited and future-proof scalability.

The 25kW inverter provides the same scalability for fuel cell and battery connections while also

providing both single- and three-phase grid formation. Both solutions are bi-directional and can be used as both a rectifier and an inverter for hydrogen applications. They can also be customized to fit every practical hydrogen scenario.

Prodrive Technologies is a developer and manufacturer of high-tech electrical, mechanical, and computing components for applications in demanding industries, including semiconductor, energy, and industrial. Prodrive Technologies' business model is based on a combination of its own R&D and in-house high-tech production facilities, with a total workforce of approximately 2,500 FTE, of which 600 in R&D. Reported turnover over 2023 amounted to €487 million.

**Proton Ventures B.V.**

Karel Doormanweg 5  
3115 JD Schiedam  
The Netherlands

+31 (0)10 426 72 75  
www.protonventures.com  
info@protonventures.com



Proton Ventures is an engineering company specialised in ammonia related technology and products. Proton Ventures is experienced in building and running pressurised and refrigerated ammonia terminals. Therefore our portfolio ranges from liquid chemical storage facilities, De-NO<sub>x</sub> and N<sub>2</sub>O removal systems up to modular production facilities of green ammonia. Hence, Proton Ventures is an experienced partner when it comes to hydrogen carrier and storage concepts needed for the energy transition. Next to this, Proton Ventures also enables the agricultural industry to switch towards green fertilisers. Whether you need a new facility built from the ground up, or an existing one upgraded, we are happy to be of service. Our team consists of talented developers, design engineers and project managers whom develop, design and

execute projects, meeting your requirements and exceeding your expectations.

Our modular ammonia plants are based on our NFuel concept. The feedstock for this ammonia production is power produced from renewable sources (solar, wind turbines, hydro). This new concept allows production of green ammonia in a de-centralised fashion, which can be further used as:

- Nitrogen carrier (fertiliser)
- Hydrogen carrier/storage
- (Combustion) Fuel

As a basic starting point for our designs, Proton Ventures works with three different production capacities. Within this range of the capacities Proton Ventures deals with the supply and demand of the energy market.

**Pure Water Group**

Jerry Hager  
Korte Hei 3  
4714 RD Sprundel  
The Netherlands

+31 (0)165 348 252  
www.purewatergroup.com  
info@purewatergroup.com

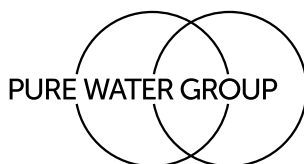

Pure Water Group is globally renowned as a leading manufacturer of advanced and sustainable water purification equipment for the production of Ultrapure water and have been serving the Power Generation, Micro-electronics and Pharmaceutical Industries for more than 25 years.

Pure Water Group: Engineering Purity

We partner with innovative technology suppliers to develop and expand our product range and one of our core technologies is CEDI - Continuous Electrodeionization. CEDI forms part of the water preparation process for Hydrogen Electrolysers and offer significant technical and environmental advantages over other processes. As specialists in this technology, Pure Water Group has unparalleled experience in the design, manufacture and support for high-capacity systems that will be required for the scale up of Hydrogen projects.



**PwC**

Esther van der Vleuten  
Thomas R. Malthusstraat 5 /  
Fascinatio Boulevard 350  
1066 JR Amsterdam /  
3065 WB Rotterdam  
The Netherlands

+31 (0)6 5115 90 81  
www.pwc.nl  
esther.van.der.vleuten@pwc.com



PwC is one of the global leading energy transition tax and advisory firms. We understand the challenges resulting from the fundamental changes to the energy system. For the energy transition hydrogen is an essential energy carrier. Without hydrogen it will be hard to meet the ambitious climate targets. We support both leading companies in the hydrogen industry, as well as Dutch government on the challenges of this quickly developing and innovative industry.

and infrastructure by tapping into all opportunities to optimise their investments. We assist companies and governments with understanding the challenges related to hydrogen projects and ensure these projects are optimally prepared for access to (equity) funding, green (project) financing, subsidies and other European and local (tax) incentives. With our vast global network, we are also well positioned to help companies expand cross border.

We help solve these important problems, with our broad industry knowledge, deep technical financial expertise and thorough understanding of the technical challenges. We help companies turn their (infrastructure) projects with high capex and uncertainties into a success or assist governments in kickstarting a hydrogen market

We can support from the early stages (market analyses and -entry studies, feasibility studies, business case set-up), towards the realisation (funding, financing, subsidies) until exploitation (management, reporting and compliance).

**RAI Automotive Industry NL**

Freek de Bruijn  
Automotive Campus 30  
5708 JZ Helmond  
The Netherlands

+31 (0)6 5040 3057  
www.rai-automotiveindustry.nl  
info@raivereniging.nl  
f.d.bruijn@raivereniging.nl



Cluster organization RAI Automotive Industry NL facilitates a network of companies, active in the Dutch Automotive Industry, that maintain and strengthen their international innovative lead through mutual cooperation and collaboration with government and knowledge institutions. Making a social contribution plays an important role and therefore all activities are aimed at realizing the following ambitions:

- Zero emission
- Zero congestion
- Zero accidents

Together with over 30 entities across the Netherlands we facilitate for the development of three hydrogen technologies: hydrogen combustion engines, hydrogen fuel cells, and a next-generation hydrogen refueling infrastructure technology.

These main developments in this project are related to cross-sectoral mobility applications for the automotive, marine, and non-road mobile machinery sectors, and the resulting technical requirements of the products from the end-user's perspective. The project also takes into account legislation and regulations and other market-specific factors. With this, the consortium partners aim to accelerate and improve the transition to sustainable mobility and to strengthen their (international) competitive position on the market for sustainable mobility applications and power units.

RAI Automotive Industry NL is a part of the RAI Vereniging and together represent the interests of the Dutch automotive industry on a national and an international level.

**RAP Clean Vehicle Technology**

Gert-Jan Rap  
Beekstraat 8A  
7227 NC Toldijk  
The Netherlands

+31575451513  
www.rap.ac  
info@rap.ac



Over 35 years experience in development, homologation, training and commercialisation of components and systems for gaseous fuel propulsion

- LPG            Liquefied Petroleum Gas
- CNG           Compressed Natural Gas
- LNG           Liquefied Natural Gas
- Bio-Methane   Upgraded Biogas
- H2             Hydrogen

on :

- engines
- on-road vehicles Light Duty and Heavy Duty
- off-road vehicles & non-road applications
- vehicle repair workshops

**REDstack B.V.**

P. Hack  
Graaf Adolfstraat 35 G  
8606 BT Sneek  
The Netherlands

+31 (0)515 745 582  
www.redstack.nl  
p.hack@redstack.nl

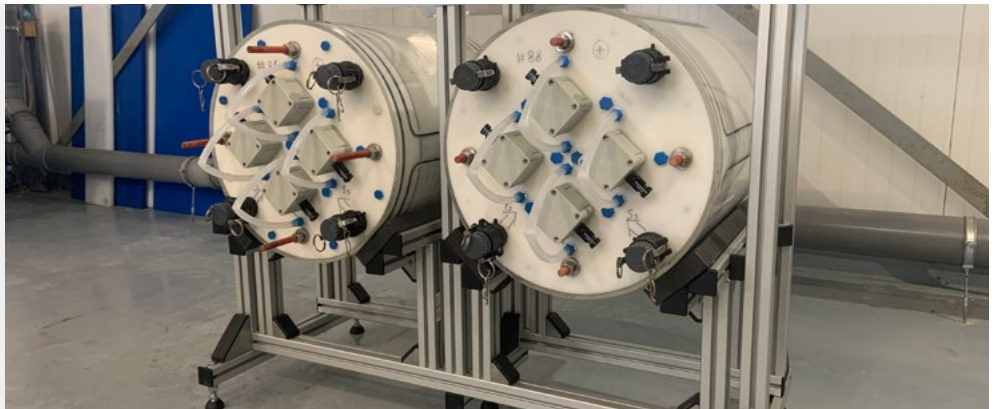

REDstack is an impact scale-up company, developing and implementing technology and membrane-stacks, for per example:

Reversed Electro Dialysis for sustainable and continuous power generation out of 2 waterflows with different salinities. The Pilot-Plant at the Afsluitdijk is running successful, and now ready for upscaling into a 0.5 MW Demonstration-Plant. The stacks generate DC, full continuous and very suitable for feeding directly into Hydrogen Electrolysers.

Electro Dialysis for water desalination. The new developed ED-technology and ED-stacks from REDstack have a significant lower energy consumption than traditional stacks. Industrial Electro Dialysis applications, per example for Nutrient recovery.

The stacks and system-design and supply is done in close cooperation with companies within the group: W&F Technologies and Pure Water Systems.

As REDstack has significant experience in designing and assembling various membrane-stacks, REDstack is a good partner in developing and realizing alkaline Hydrogen Electrolysers.

## Remeha

Maurice Meulenbrugge  
Marchantstraat 55  
7332 AZ Apeldoorn  
The Netherlands

+31 (0)55 549 69 00  
www.remeha.nl  
info@remeha.nl



Remeha develops innovative and energy-efficient products for climate control or heat and hot water, both for homes and utilities. With more than 700 employees, Remeha has grown into a leading manufacturer in the Netherlands and Europe. Remeha heats more than 2 million homes in the Netherlands and is also the market leader in non-residential construction. By making sustainable indoor climate solutions feasible and affordable, the company wants to make an important contribution to a CO<sub>2</sub>-neutral society. Remeha is one of the main brands within BDR Thermea Group. BDR Thermea Group in Apeldoorn achieved a turnover of € 2.2 billion in 2022 with more than 6,800 employees and sales activities in more than 100 countries.

Remeha started developing the first hydrogen boiler for homes in 2017. Since 2019, Remeha has gained extensive experience in heating homes and apartments with hydrogen. For example, in 2019 Remeha was involved in heating an apartment complex

in Rozenburg with hydrogen. At the time, this was the first hydrogen application in the world in a residential building. This was followed by successful hydrogen projects in existing and new homes.

Hydrogen projects for utility buildings have already started. Remeha uses proven natural gas boiler platforms to control hydrogen boilers for both residential and non-residential buildings, which also meet the highest standards in combination with heat pumps or propane. The well-known Quinta platform is available for the utility market, which is scalable to larger capacities. Remeha has developed three 100% hydrogen boilers with different capacities for pilot projects

Remeha believes in several paths to sustainability: gases, electricity and heating networks. We see the solution in the combined use of energy carriers, appropriate to the environment and existing infrastructure. Hydrogen is a promising energy carrier by which we are 'Creating better living environments'.

## Resato Hydrogen Technology

Francois Hemmerlin  
Duitslandlaan 1  
9403 DL Assen  
The Netherlands

+31 (0)50 501 68 77  
www.resato-hydrogen.com  
sales@resato-hydrogen.com



Resato is a Dutch provider of smart high pressure solutions with the aim to increase the productivity of its worldwide customers. It is our mission to meet and exceed the expectations of our customers. With more than 25 years of experience in high pressure technology, we are equipped with the knowledge to provide reliable and safe solutions. We want to support the hydrogen mobility sector with our high pressure solutions.

Therefore we have developed hydrogen refueling stations to tackle the 'chicken and egg' dilemma: there is a lack of hydrogen filling stations due to a shortage of hydrogen cars, and vice versa. Resato's vision is to meet this challenge with compact and efficient refueling solutions that support the development of a hydrogen economy.

For smaller hydrogen-powered vehicle fleets, such as cars and buses, hydrogen is still not readily available. By developing a compact and cost-efficient refueling station (Fleet Owner Station), the first step has been taken to break through the high investment and make it possible for companies with fleets to refuel with hydrogen.

This way, the number of hydrogen filling points can be increased. When demand grows, the compact stations can be replaced by a centrally located public hydrogen station, where you can refuel your car within 3 minutes. This makes it easy to expand the network by relocating the compact filling stations.



**RN Solutions B.V.**

Paul Buijs  
Van Humberghlaan 46  
5491GN Sint Oedenrode  
The Netherlands

+31 (0)6 1593 7341  
www.rnsolutionsbv.com  
paul.buijs@rnsolutionsbv.com



RN Solutions B.V. is a developer and manufacturer of highly efficient patented membrane distillation (MD) modules. The modules have been extensively tested on seawater, river water and on industrial applications. Using waste heat of the electrolyser or other heat sources, MD produces pure water with a conductivity of less than 5  $\mu$ S/cm in one single step. The membrane is highly hydrophobic (water repelling) and allows only water vapor to pass, retaining all salts at the feed side.

The process operates at a low pressure (1 bar), therefore the additional electrical power requirement is low. Furthermore, plastic piping can be applied (polyethylene, polypropylene or PVC). As the membranes are homogeneous, reverse flow can be applied in case of fouling of the feed channel. This can simply be automated,

requiring no operator intervention. The process needs a limited pretreatment.

The most commonly applied desalination technology, reverse osmosis (RO), operates at 60 bar, therefore requires more electrical power and the use of chloride tolerant stainless steel materials. The membranes are layered composite materials, reverse flow will irreversibly damage the membranes. To reach a similar low conductivity, reverse osmosis needs a double pass for seawater desalination, and an intensive pretreatment. Antiscalants are required, and cleaning of the membranes requires operator intervention.

**Royal HaskoningDHV**

Juriaan Mieog  
Laan 1914 35  
3818 EX Amersfoort  
The Netherlands

+31 (0)88 348 28 87  
www.royalhaskoningdhv.com  
juriaan.mieog@rhdhv.com



Royal HaskoningDHV has been an independent engineering services, consultancy and project management agency since 1881. Our nearly 6,000 professionals worldwide innovate by collaborating with customers and partners to have a positive impact on people, the environment and the economy.

We advise companies and (semi) governments on all parts of the hydrogen chain, from the first idea to the conceptual design phase. We provide technical-economic feasibility studies in which we involve stakeholders and society. We also provide specific services related to safety, permits, legal and policy advice.

We are active in all parts of the hydrogen chain, including the demand-side options. For us, one of the major challenges is to bring the high level

ideas to realisation as many parts of the chain are still in development, both in the technologically as well as organisational and regulatory.

Next to that we understand that hydrogen has a key role in energy transition and complements electricity to have a sustainable energy system. As such, H<sub>2</sub> may be the best option, but in other cases a different solution such as electrification or CCS may be the most optimal option.

RHDHV has carried out over 50 hydrogen projects in various roles. These are projects for the production and import of hydrogen, such as our 1 GW parametric design; transport and storage like a QRA for a H<sub>2</sub> pipeline or in the use phase the development of the business case for H<sub>2</sub> buses.

**RWE**

Lijs Groenendaal  
Stadsplateau 37  
3521 AZ Utrecht  
The Netherlands

[https://benelux.rwe.com/  
contact-en-diensten](https://benelux.rwe.com/contact-en-diensten)

[https://benelux.rwe.com/  
onze-energie/waterstof/  
rwe-benelux@rwe.com](https://benelux.rwe.com/onze-energie/waterstof/rwe-benelux@rwe.com)



# RWE

RWE is leading the way to a green energy world. Between 2024 and 2030, RWE will invest 55 billion euros worldwide in offshore and onshore wind, solar energy, batteries, flexible generation, and hydrogen projects. By the end of the decade, the company's green portfolio will grow to more than 65 gigawatts of generation capacity, which will be complemented by global energy trading.

With its investment and growth strategy Growing Green, RWE is contributing to the energy transition and decarbonisation of the energy system. Hydrogen is a cornerstone of industrial decarbonisation and offers enormous potential for the energy transition. As a leading producer of electricity from renewable energies, RWE can supply the clean electricity and has the necessary technical expertise needed to produce green hydrogen.

RWE has set a clear growth target in electrolysis capacity: 2 GW electrolysis by 2030, driven by a growing project pipeline of over 10 GW. The project portfolio comprises more than 30 integrated projects along the entire value chain in The Netherlands, Germany, the UK and other focus markets.

RWE is decarbonising its business in line with the 1.5-degree reduction pathway and will phase out coal by 2030. The company will be net-zero by 2040.

RWE: Our energy for a sustainable life.

**SALD B.V.**

Erik Kremers  
Luchthavenweg 10  
5657 EB Eindhoven  
The Netherlands

+31 (0)40 238 05 00  
[www.spatialALD.com](http://www.spatialALD.com)  
[info@spatialALD.com](mailto:info@spatialALD.com)



SPATIAL ALD  
INNOVATORS

With 'Spatial Atomic Layer Deposition', SALD has developed a globally unique, patented process for applying functional nanolayers as thin as a single atom on an industrial scale. These conformal nano coatings are deposited via a self-limiting gas-phase process with web speeds up to 90 meters/min. We can apply it under ambient conditions on nearly any substrate, like metal, glass, wafers, plastics, textiles or membranes. Spatial ALD

process will revolutionize entire industries, including the electrolysis technology industry, the production of battery cells for cars and smartphones, the textile industry, printed electronics (organic computer chips), the new solar energy industry and the packaging industry for consumer goods and convenience food.

## Samotics

Simon Jagers  
Bargelaan 200  
2333 CW Leiden  
The Netherlands

+31 (0)6 53 32 52 56  
www.samotics.com  
info@samotics.com



Samotics seeks to address the factors that contribute towards an efficient operation of AC-driven rotating assets, and with it reduce electricity consumption and GHG and carbon emissions. AC motors are an integral asset across various industries. These motors however, have critical problems, such as failing unexpectedly, being used inefficiently, and being selected inadequately (right sizing). Energy waste occurs as a result of all three of these factors. Samotics strives to solve these three issues by providing a combined energy and condition monitoring service, called SAM4.

SAM4 is a plug-and-play solution and service for critical AC motors and rotating equipment. SAM4

utilizes electrical signature analysis (ESA) and powerful AI-driven algorithms, which use voltage and current data of AC motors and rotating equipment. This data is obtained by plug-and-play, easy to install (and scale), SAM4 hardware, which is installed in the easy to reach and safe environment of the motor control cabinet of the assets, instead of on the assets themselves. To date Samotics has 120+ clients to which energy and condition monitoring services are provided and is monitoring thousands of assets in the field. Moreover, Samotics has multiple global partnerships, amongst others with Schneider Electric. Would you like to get know more about our solution, SAM4, do not hesitate to reach out.

## Saxion University of Applied Sciences

B.J. Aalderink  
M.H. Tromplaan 28  
7513 AB Enschede  
The Netherlands

+31 (0)88 019 8888  
<https://www.saxion.nl/onderzoek/areas-and-living/duurzame-energievoorziening>  
b.j.aalderink@saxion.nl



Saxion is an open and accessible university of applied sciences which provides solutions to social issues through education and applied research. The current energy transition is unmistakably a big challenge for society in which Saxion is taking up its role. Both in educating young professionals to support the required work force for the transition, but also by means of application research that brings together researchers, industry and students around energy related topics. The important role of hydrogen in the transition is acknowledged and has a role in the various academies and research groups. This includes technical aspects of the hydrogen applications, but also sociological, economical

and legislative aspects that play a role. Within the group of Sustainable Energy Systems, one of the research lines focusses on industrial use of hydrogen, including high temperature heating applications and the generation of green molecules. We are involved in several hydrogen related projects (e.g. RELEASE, GROHW, HYGENESYS and Hydrogen Connect 2020-2030) and are closely working together with the H2Hub Twente fieldlab (Almelo, the Netherlands). Together with the HAN University of Applied Sciences we are a strong applied hydrogen knowledge and research group in the Eastern Netherlands with a strong regional, national and international network.



**Schaeffler Nederland B.V.**

Sander ten Hoopen  
Koolhovenstraat 2  
3772 MT Barneveld  
The Netherlands

+31 342 40 30 00

<https://www.schaeffler.com/en/technology-innovation/hydrogen-technology/>

[hydrogen@schaeffler.com](mailto:hydrogen@schaeffler.com)



## SCHAEFFLER

The Schaeffler Group has been driving forward groundbreaking inventions and developments in the field of motion technology for over 75 years. With innovative technologies, products, and services for electric mobility, CO<sub>2</sub>-efficient drives, chassis solutions, Industry 4.0, digitalization, and renewable energies, the company is a reliable partner for making motion more efficient, intelligent, and sustainable – over the entire life cycle.

Schaeffler's expertise in production technology is a decisive success factor in this growing market. Electrolyzer stacks based on PEM technology, ranging from 1kW to 1000kW of electrical power, are already today part of Schaeffler's product portfolio for the rapidly growing market for green hydrogen production and R&D applications.

**Schwank BV**

Wilfred Heesakkers  
Vaart 7a  
4206 CC Gorinchem  
The Netherlands

+31 0183 766 050

[www.schwank.nl](http://www.schwank.nl)  
[info@schwank.nl](mailto:info@schwank.nl)

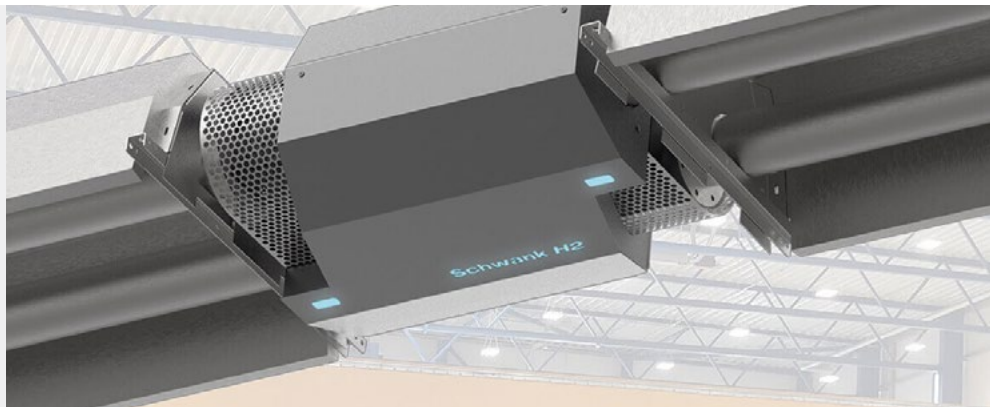

Schwank is a world market leader in the manufacture and supply of technologically advanced heating and cooling systems, sophisticated HVAC products and comprehensive customer support services. We are at the leading edge in our field of engineering and are committed at all times to exhibiting the hallmarks of "Made in Germany" quality.

With the geniumSchwank, Schwank has created the world's first 100% hydrogen industrial heating system. With this new, unique heating system, an important development step and innovative breakthrough for the use and sustainability of H<sub>2</sub> has been achieved. And even better: geniumSchwank is so revolutionary because not only hydrogen, but also natural and liquid gas can be used.

With this multi-gas approach, the system adapts to the demands of today: Flexibility in terms of the environment – flexibility in terms of economic efficiency. Companies that want to continue using the advantages of natural gas today, but are planning to go down the path of hydrogen as an energy carrier tomorrow, need future-proof solutions like the geniumSchwank. Because it can be adapted to hydrogen in just a few steps.

### SHV Energy N.V.

Sustainable Fuels: Attention Hydrogen Team  
Capellalaan 65  
2132 JL Hoofddorp  
The Netherlands

+31 (0)23 555 57 00  
www.shvenergy.com  
sustainablefuels@shvenergy.com



SHV Energy is a Netherlands based, family owned multinational distributing LPG, LNG and sustainable fuels servicing the energy needs of over 30 million customers worldwide.

We are proud to provide energy for hundreds of applications, ranging from cooking to heating to powering low-polluting vehicles. Through our local brands including Calor, Primagaz, Ipragaz, Liquigaz, Supergasbras, Xiwei, Supergas and Pinnacle Propane, we serve our customers through our market-leading LPG companies on four continents: Europe, Asia, North and South America. It is our mission to help clients find unique energy combinations, going beyond our responsibility of simply supplying energy.

Everyday we provide people and businesses beyond the gas grid with the opportunity to switch from high-polluting, carbon-intensive fuels to cleaner forms of energy. In 2018, we pioneered the launch of renewable propane (also known as bioLPG) to offer our customers a drop in replacement with up to 80% carbon reduction. Our activities within our Sustainable Fuels team are to explore, encourage and develop solutions for decentral off-grid domestic heating and cooking, industrial process heat and transportation applications. We already operate Hydrogen infrastructure in China and we see long term potential for global growth. Our focus is on collaborative action to tackle the challenges of green hydrogen for off-grid production and usage.

### Sia Partners

Robin Brouwer  
Amstelplein 1  
1096 HA Amsterdam  
The Netherlands

+31 (0)6 8296 4437  
www.sia-partners.com/en  
robin.brouwer@sia-partners.com



Sia Partners is a next-generation consulting firm focused on delivering superior value and tangible results to its clients as they navigate the digital revolution. Sia Partners was founded in Paris in 1999. Today, Sia Partners is still headquartered in Paris but developed into an organization with over 1800 consultants, active in 31 offices around the world.

With its global expertise in the energy sector and its recognized know-how in business transformations, Sia Partners is able to seize the opportunities offered by hydrogen to its clients from a business and technology perspective. The added value of Sia Partners:

1. Our teams work on projects all along the energy value chain – from strategic to operational steps – and are therefore familiar

with a large spectrum of actors/possible partners;

2. Sia Partners' expertise on the energy sector, especially on the stakes of energy transition and;
3. Sia Partners' knowledge on the hydrogen market and the actors of the ecosystem, which is deeply fragmented.

So far, Sia Partners has helped major gas infrastructure companies, energy producers, energy suppliers and research and knowledge institutions on a wide variety of hydrogen projects. Examples of Sia Partners' project focus areas are contextualization and challenges of the hydrogen sector, definition of hydrogen development strategies, support for project management and development of analytical tools.

Siemens Energy B.V.  
Stadhouderslaan 800  
2382 BL Zoeterwoude  
The Netherlands

[www.siemens-energy/hydrogen](http://www.siemens-energy/hydrogen)  
[enquiries.nl@siemens-energy.com](mailto:enquiries.nl@siemens-energy.com)



Energy transition is the greatest challenge our generation faces. How do we reduce emissions while also increase energy supply? It is an uphill battle. And there is no silver bullet. But finding solutions has always been in our DNA. For more than 150 years our engineers have been spearheading the electrification of the world. Today we are a team of 96.000 sharing the same passion, vision and values. Our diversity makes us strong and helps us to find answers together with our partners.

Located in 90 countries, Siemens Energy operates across the whole energy landscape. From conventional to renewable power, from grid technology to storage to electrifying complex industrial processes.

Our mission is to support companies and countries with what they need to reduce greenhouse gas emissions and make energy reliable, affordable, and more sustainable. Let's energize society. Our portfolio includes conventional and renewable energy technology, such as grid technology with switchgear, transformers, rectifiers, grid stability solution, substations, battery solutions and grid consultancy. Working towards a hydrogen economy, our gas-turbine portfolio for industrial and power generation applications is 'hydrogen ready'. With our electrolyser portfolio and compression technology for a wide range and application of gases, we can support customers for (larger scale) hydrogen and power-to-x projects. With our portfolio for (industrial scale) heat pumps, fuel cells and digital and automation solutions, we can provide both single and hybrid solutions across our portfolio.

#### Solstice Management B.V.

Jan Kruse  
Verkavelingsweg 8  
8061PK Hasselt  
The Netherlands

+31 6 5315 5113  
[www.solstice-management.com](http://www.solstice-management.com)  
[jan.kruse@solstice-management.com](mailto:jan.kruse@solstice-management.com)



Solstice Management BV was founded in 2016, and has experienced rapid growth and expansion ever since. Solstice Management BV is providing financial advisory services and is a specialist Business Development consultancy, strong in advisory and non-executive board roles. We offer procurement advice as well as specialized services for the search of suppliers and clients, for small and medium sized companies, especially in the green hydrogen eco-system, plastic pipe and fittings industry, water treatment and recycling, sanitation as well as in renewable energy systems. Our area of interest is focused on Southern Africa, operating from Windhoek / Namibia.

Subsidiary Taatisolar Namibia (Pty) Ltd. is importing and distributing Solar Home Systems and DC appliances for the off-grid market in Namibia. With networks in the Netherlands as well as in Namibia, Solstice Management B.V. is well placed to support

Dutch companies in finding relevant counterparts as well as identifying market needs. A report on the propositions Namibia offers in green hydrogen has already been prepared for RVO. Further research is conducted on the local Namibian needs for skills development and capacity building in the green hydrogen eco-system.

Solstice Management is planning to play an active role around the Africa Green Hydrogen Summit during 3-5 September in Windhoek.



**SoluForce B.V.**

Robert-Jan Berg  
Flevolaan 7  
1601 MA Enkhuizen  
The Netherlands

+31 (0)228 355 688  
www.soluforce.com  
info@soluforce.com



# SoluForce®

SoluForce offers a safe, sustainable, cost-efficient and, above all, quickly deployable infrastructure for local hydrogen distribution.

Originating as a corrosion-free solution for fluid and gas transport, SoluForce Reinforced Thermoplastic Pipes (RTPs) have become synonymous with reliable (energy) infrastructure. They are used for many applications, such as hydrogen, hydrocarbons, water, offshore and mining. With over 4000 km of installed pipeline worldwide, SoluForce continues to revolutionize the way energy is transported.

SoluForce flexible pipelines play a pivotal role in various hydrogen projects. From decentralized hydrogen production to industrial applications, SoluForce solutions are versatile and impactful. Being non-metallic, they are fully corrosion-free

and do not suffer from hydrogen embrittlement. The key advantages of the SoluForce system is their significantly lower CO2 emissions and Total Cost of Ownership compared to traditional pipelines. Plus, the coil-based supply system streamlines logistics and installation, providing substantial time and cost savings.

Based on proven technologies, it can be the perfect accelerator to achieve local (green) hydrogen distribution in a fast, flexible and cost-efficient manner. This certified and ready to use pipeline solution has a major impact on the feasibility of (green) hydrogen projects and a sustainable energy mix.

**Sorama B.V.**

Jerry Willems  
Achtseweg Zuid 153H  
5651 GW Eindhoven  
The Netherlands

+31 040 304 1019  
www.sorama.eu  
sales@sorama.eu



# Sorama

Sorama is a deep-tech company from the Brainport region in Eindhoven, market leader in the production of acoustic cameras aimed at detecting and visualizing sound for various (industrial) applications. Our team of approximately 80 employees is committed to developing innovative solutions for gas and air leaks, partial discharge, and mechanical inspections with anomaly detection in hazardous zones.

Sorama's advanced acoustic cameras are designed to efficiently detect and visualize gas leaks, including hydrogen. This is critical for safety, but also plays a vital role in minimizing financial losses caused by undetected leaks. Sorama already demonstrated technological innovations in robotics, handheld and fixed installations within the international hydrogen sector.

Applications for the hydrogen sector include;

- Hydrogen leak detection
- Partial discharge detection
- Mechanical inspections (anomaly detection)

Our acoustic cameras can be integrated into third party systems and various robotics platforms. When you want to discuss how we can support you with localization of leaks, partial discharge or mechanical inspections, please visit our website or contact us.

### SparkNano

Koen Driessen  
Esp 266  
5633 AC Eindhoven  
The Netherlands

+31 (0)6 1485 2921  
www.spark-nano.com  
info@spark-nano.com



SparkNano is a high-tech product company that designs and commercializes Spatial Atomic Layer Deposition tools (S-ALD) redefining nanofabrication on an industrial scale.

SparkNano's Spatial ALD technology enables its customers to deposit thin, functional layers, thereby increasing performance and reducing costs for manufacturing fuel cells, batteries and solar cells.

SparkNano's patented technology plays a critical role in addressing the global challenge of creating a sustainable way of generating, storing, and converting energy. It provides solutions by significantly reducing the waste of scarce materials used in electrolysers and enhancing the performance, lifetime, and stability of next-generation fuel cells, batteries, and solar cells.

SparkNano's product range includes versatile and flexible R&D tools for process development and pilot production (Labline series) and fab tools for mass production on planar, porous, and flexible substrates,

either via sheet-to-sheet (Vellum) or roll-to-roll (Omega) series respectively.

Each product is based on atmospheric pressure Spatial ALD, either thermal- or plasma-enhanced. This technology enables the deposition of thin films with atomic-scale precision and uniformity at high speeds and large areas, ensuring a low cost of ownership. Furthermore, SparkNano offers customers a total solution, including production ramp-up support, recipe development, and application and process support resulting in a seamless Lab to Fab transition.

Founded in 2018, the company has built extensive application knowledge and a network consisting of major technology research centers, market-leading technology companies, and technology partners. These include TNO, Holst Center, Solliance, Eindhoven University of Technology (TU/e), VDL, and Air Liquide.

### R. Stahl Electromach

Marc Zengerink  
Jan Tinbergenstraat 193  
7559 SP Hengelo  
The Netherlands

+31 (0)6 13 20 97 43  
www.zone-atex.nl  
marc.zengerink@r-stahl.com



R. Stahl Electromach is an international leading design company with an extensive engineering and manufacturing expertise in explosion proof control systems. Our components and systems can be applied in areas where gas and dust explosions may occur. Therefore, we are the obvious partner of choice for oil, gas, petrochemical and offshore applications such as in refineries and oil and gas.

All safety solutions by R. Stahl Electromach are customer-based and include the development of application software, manufacturing, assembly, testing and on-site commissioning. R Stahl Electromach offers these solutions as full-service packages, from consultation and conceptual design to operation. We also take care of all international certification and providing after-sales support.



**Stork**

Willem Hazenberg  
Van Deventerlaan 121  
3528 AG Utrecht  
The Netherlands

+31 (0)88 089 10 00  
www.stork.com/  
www.stork.com/en/industries/hydrogen  
amt@stork.com



Stork is a leading provider of integrated operations, maintenance, modifications, and asset integrity solutions, driven by a mission to set new industry standards. With a dedicated team of 2,500 professionals in the Benelux and over 60 years of experience in Hydrogen projects, we are in pole position for the transition to green energy and involved in numerous green Hydrogen projects.

We have conducted extensive market studies on Hydrogen for the EU, investment companies and local authorities, built the Netherlands' first 1 MW electrolyser, and are currently leading the construction of a new 200 MW electrolyser Hydrogen plant. Our expertise spans master planning, engineering, construction, asset management, and maintenance, emphasizing our comprehensive approach to transformative projects.

Our involvement in energy and Hydrogen partnerships, educational initiatives, and standardization efforts, alongside our role in hydrogen-powered residential heating projects, demonstrates our commitment to sustainable energy solutions. We are also a frontrunner in hydrogen and oxy fuel combustion with our own burner design.

As part of the Bilfinger, one of the world's largest publicly traded technical service companies, we leverage over 190 years of industrial experience to offer end-to-end Hydrogen asset lifecycle solutions, marking our place in the energy transition towards a sustainable future. Join us in leading the charge where integrity, innovation, and sustainability meet excellence.

**Strohm BV**

Natasja de Jong  
Monnickendamkade 1  
1976 EC IJmuiden  
The Netherlands

+31 255 76 35 85  
https://strohm.eu  
n.dejong@strohm.eu



As the leading composite pipe technology company, Strohm boasts the world's largest track record for Thermoplastic Composite Pipe (TCP) since pioneering its use in the Oil & Gas industry in 2007. TCP not only reduces total installed and life cycle costs for subsea flowlines, jumpers, and risers but also slashes pipeline infrastructure CO2 footprints by over 50%. Committed to sustainability, our TCP solutions propel clients toward net-zero carbon emissions targets and bolster the renewables sector.

Recognizing the synergy between clean hydrogen and offshore wind early on, we developed a compelling pipe solution to support this alignment. Pipelines, capable of transferring up to nine times more energy than cables, serve as hydrogen storage units, enhancing offshore wind farm uptime. Our TCPs, known for flexibility, lack of

corrosion, fatigue, or embrittlement, emerge as the superior pipeline solution for offshore wind farms generating hydrogen.

Strohm's unique value proposition, widely accepted and field-proven in the offshore oil and gas sector, is recognized in the offshore wind to hydrogen realm as an enabler for large-scale developments, replacing cables with TCP. Anticipating further opportunities in this space, we expect expansions of our production capacity. We eagerly anticipate shaping the future of the energy landscape with our TCP solutions. Reach out to discover how we can support your operations!



**Summit Engineering B.V.**  
 Arjan Hartemink  
 Burgemeester J.G. Legroweg 45A  
 9761 TA Eelde  
 The Netherlands

+31 (0)6 1100 5689  
 www.summitengineering.nl  
 arjan@summitengineering.nl



“Leaving a world to thrive in for future generations.”  
 We want to use our personal energy for that.

Summit Engineering was founded by Arjan Hartemink and Robbert van der Pluijm after a trip to Mount Kilimanjaro. The journey to the top and back, has inspired them in many ways. The glacier at the summit is becoming smaller every year due to global warming. Being confronted with this so closely, was the final push: we have to do something.

Summit Engineering now supports companies and governments with their Energy Savings Programmes and Sustainable Energy Projects. We also share our knowledge with the future generation by teaching classes at universities. Together we work on reducing CO<sub>2</sub> emissions and on taking steps towards

a CO<sub>2</sub> neutral world. Hydrogen can play an important role in achieving this goal.

At Summit Engineering we have experience in the various aspects of the hydrogen supply chain. From production, to transport storage and utilisation in different areas. We provide concrete advice and excellent project support you can count on. Whether you are at the concept phase of your project or already working towards project implementation.

We use our knowledge, experience, as well as our extensive sector network, to provide a tailor-made programme for achieving optimal results.

**SuWoTec B.V.**  
 Lammert de Wit  
 Boerhaavestraat 28  
 9501 HE Stadskanaal  
 The Netherlands

+31 (0)6 53 23 09 56  
 www.suwotec.com  
 lammert.dewit@suwotec.com



To secure a sustainable future for generations to come, We develop sustainable circular technologies that are inspired by the way nature works.

First understand nature.

Nature has its own unique ways and systems to create, utilize and recycle. These are proven processes, fine-tuned over thousands of years. More often than not, the way we humans have built today's energy and transport infrastructure, however, follows completely contrary ideas. Then, develop game-changers.

Identifying nature's fundamentally efficient and resilient processes, we develop game-changer technologies that are circular by design and feasible over time. Our work must have a positive effect on people and planet, right where it matters most.

One of the game changers is the development of non-corrosive electrodes and membranes. Ongoing development for electrolyzers, fuel cells, batteries, water cleaning and carbon capture. Electrodes with longer life time and not participating in the process. We expect suitable for multiple energy carriers next to hydrogen.

### Swagelok Nederland

Aletta Keijzer  
Coenecoop 19  
2741 PG Waddinxveen  
The Netherlands

+31 (0)88 909 07 07  
nederland.swagelok.com  
info@swagelok.nl

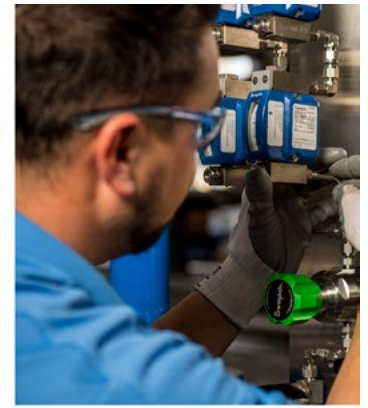

Swagelok actively supports companies developing alternative fuel technology for the any industry, designing fluid system components and assemblies for use in hydrogen applications. We not only understand the fluid system performance needs of the industry, but also the complex approval processes and compliance requirements that govern them. We provide solutions that range from easy-to-install tube fittings to custom-designed fluid system assemblies that deliver longlasting performance in hydrogen applications. We also provide fluid system evaluation and advisory services to help customers improve the performance of their existing systems, and we provide product design support for fuel systems in vehicles and filling station infrastructure. Swagelok products and services are also integral to success in transportation industry sectors including shipbuilding, aerospace, and tire manufacturing.

Our widely certified fluid system products are the standard choice for use in many military and commercial maritime applications. At Swagelok, we recognize that safety is often the number one priority of our customers, especially those working with and transporting highly volatile fluids as part of their daily business. We can help you build safety into your fluid system-related practices from installation through routine maintenance. We provide:

- A comprehensive program of safety training and competency skills development
- Leak-tight fluid system designs based on best practices for operator safety
- Evaluation and advisory services that help you address risk factors throughout your fluid systems
- High-quality Swagelok components and assemblies engineered and tested to be safe to operate and maintain throughout their lifecycles.

### Tebulo Engineering

M. de Jong  
James Wattstraat 25  
1817 DC Alkmaar  
The Netherlands

+31 (0)72 200 51 23  
www.tebulo.com  
info@tebulo.com



The sectors for which we carry out our engineering work are Chemicals and Petrochemicals, Offshore, Food, Utilities and Energy, Nuclear, Pharmaceutical, Automotive and Steel industries.

The projects mostly concern front-end engineering processes. However, parts of this, such as studies, risk inventories, basic and detailed engineering are also important activities.

The Engineering projects are multi or single disciplinary, in which Process, Piping, Mechanical, and Electrical Engineering play a leading role. Naturally, civil and structural also have their share.

We are a professionally organized engineering company and have a reputation for providing solutions that go beyond the standard. Tebulo Engineering is active in various markets, based on the broad knowledge gained, we function as a technical partner for our clients.

We do not lose sight of trust and integrity. The great diversity of clients makes it possible to realise innovative multidisciplinary projects that appeal to the imagination. Our working method is aimed at building long-term relationships. Our targeted training program ensures that our people are known with recent developments in the fields. Our designs are in accordance with current standards and legislation.

**Teesing B.V.**

Cynthia Roseboom  
Verrijn Stuartlaan 7  
2288 EK Rijswijk  
The Netherlands

+31 (0)70413 0722  
www.teeing.com  
info@teeing.com



**TEESING**

Teesing is your long-term partner for the development and supply of high-quality assemblies and related services for the transportation, control, sealing, distribution, filtration, purification, and measurement of gases and liquids.

Teesing collaborates closely with partners, both substantively and organizationally, enabling them to continuously meet the demands of their market.

**T.EN Netherlands B.V.**

Aksel Aksam / Martin van 't Hoff  
Afrikaweg 30  
2713 AW Zoetermeer  
The Netherlands

+31 (0)79 329 36 00  
www.ten.com  
TEN-Netherlands@ten.com



Technip Energies is a leading Engineering & Technology company for the energy transition, with leadership positions in LNG, hydrogen and ethylene as well as growing market positions in blue and green hydrogen, sustainable chemistry and CO2 management. The company benefits from its robust project delivery model supported by extensive technology, products and services offering. Operating in 34 countries, our 15,000 people are fully committed to bringing our client's innovative projects to life, breaking boundaries to accelerate the energy transition for a better tomorrow. Technip Energies is listed on Euronext Paris with American depository receipts ("ADRs"). For further information: [www.ten.com](http://www.ten.com).

The office in Zoetermeer is Technip Energies' center of excellence in hydrogen technologies. Competences comprise: R&D, product development (e.g. industrial burners able for 100% hydrogen firing) as well as the full spectrum of EPC expertise based on which we offer worldwide proprietary grey, blue and green hydrogen technologies as well as revamps (conversion of grey-to-blue, plant modernization (e.g. energy efficiency), capacity increase, etc.). Our services include (digital) client support in day-to-day plant operation including furnace/reformer surveys and supply of spares.



**TKI New Gas (Topsector Energy)**

J. K (Jörg) Gigler  
Groen van Prinstererlaan 37  
3818 JN Amersfoort  
The Netherlands

+31 (0)6 45 25 15 71  
www.topsectorenergie.nl/en/  
jorg.gigler@topsectorenergie.nl



Energy Innovation NL (in Dutch: Topsector Energy), is the driving force behind innovations that are necessary for the transition to an affordable, reliable and sustainable energy system. The Dutch Knowledge and Innovation Agenda, as a part of the National Climate Agreement, determines the priorities of the TSE. The specific innovation agenda of TKI New Gas focuses on the following topics:

- Hydrogen: full hydrogen chain as well as the system role that hydrogen can play
- Green gases from biomass through different processes, such as digestion, gasification and supercritical water gasification
- Capture, Utilisation and Storage of CO2
- Geo energy, with focus on subsurface innovations regarding energy storage and geothermal energy.

Hydrogen is a cross-cutting theme for our Topsector because it deals with all sectors of our national climate agreement as well as addressing the system role which could be beneficial for all stakeholders in the energy transition.

- Our main activities include 3 types of activities:
- roadmapping, such as defining innovation agendas together with Dutch stakeholders
  - facilitating innovators, for example finding partners, matchmaking and access to funding opportunities
  - communication and dissemination on activities, innovation projects, research programmes and relevant developments.
- We help innovators to contribute to the energy transition.

**TNO Process Safety Solutions**

Davide Mores  
Ypenburgse Boslaan 2  
2496 ZA, The Hague  
The Netherlands

+31 (0)6 1174 9031  
www.tno.nl/prosafe  
davide.mores@tno.nl



Hydrogen Safety and Secure Hydrogen Infrastructure are part of our broad portfolio of activities that focus on Safe & Reliable Chemistry.

We have unique capabilities for assessing the behaviour of dangerous chemicals and examine processes that operate at harsh conditions. We apply our hazardous chemistry expertise, explosion safety knowhow and highly specialized infrastructure, to assess and prevent risks related to processing, handling and storage of hazardous materials. Our unique expertise supports your pursuit towards inherent safe applications.

We have a proven track record in (customized) testing the behaviour of processes and materials linked to hydrogen. Our hydrogen expertise include:

- both liquid and gaseous hydrogen testing capabilities
- from 0 to 2000 bar pressure
- from cryogenic to high temperatures
- from lab-scale to pilot-scale.
- permeability, tensile testing, material compatibility
- explosion safety, stability, sensitivity
- consultancy

Our team of multi-disciplinary specialists and facilities allow a broad range of possibilities and enable the exploration of innovative developments without compromising on safety.

**To70 aviation**

Vincent de Haes  
Oranjestraatsingel 6  
2511 VE The Hague  
The Netherlands

+31 (0)70 392 23 22  
www.to70.nl  
vincent.dehaes@to70.com

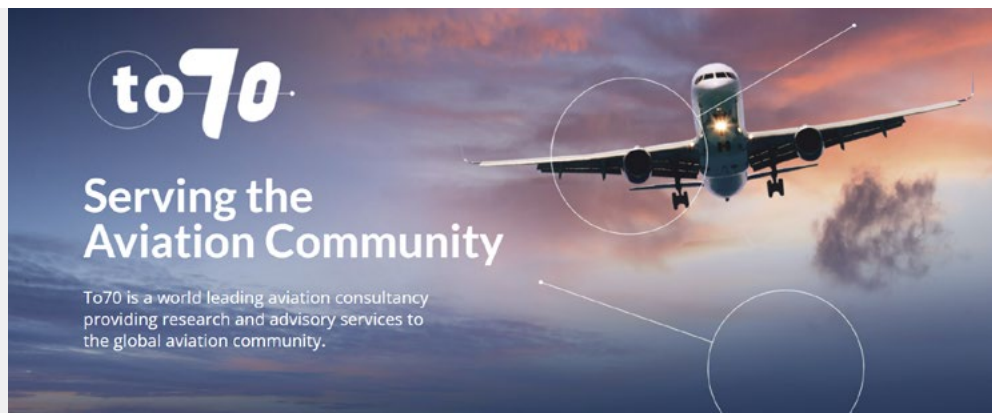

To70 is a leading aviation consultancy firm based in the Netherlands with more than 12 offices worldwide. To70 provides environmental, operations, safety and efficiency services to a wide range of stakeholders within the aviation sector. These include airports, public institutions and government bodies as well as air traffic management and private businesses. At To70 we are strongly committed to a sustainable aviation sector, and aspire to work together with our partners and clients to ensure aviation becomes carbon free and future proof.

An increasing area of attention within sustainable aviation is the development of hydrogen fueled

aircraft. Although still in the early stages of development, increased public awareness of aviation emissions as well as national and European hydrogen developments are pushing innovation. Besides changes in aircraft, the transition to hydrogen will require the wider aviation ecosystem including airports, regulatory bodies and air traffic management bodies to adapt.

At To70, we are able to provide research services and strategy guidance for hydrogen infrastructure, operations, safety and risk management. Our years of experience, international presence and sustainable vision allow us to support all stakeholders within aviation that aim to develop future hydrogen powered aviation.

**Torrgas B.V.**

Erwin Eijmans  
Herikerbergweg 292  
1101 CT Amsterdam  
The Netherlands

+31 (0)6 51 11 88 31  
www.torrgas.nl  
e.eymans@torrgas.nl



Torrgas is a leading technology company in the production of renewable syngas and bio-char. Syngas is the building block of the chemical industry. Torrgas offers viable and profitable opportunity as an alternative for the world's addiction to fossil fuels. After the torrefaction of the waste streams, the Torrgas process converts low value waste into bio-based commodity products with a high added value. Syngas is used for the synthesis of almost any bio-hydrocarbon that are currently produced from fossil fuels; among others in this case Hydrogen.

### Toyota Material Handling

Willem Stehouwer  
Stevinlaan 4  
6716 WB Ede  
The Netherlands

+31 (0)88 864 20 00  
www.toyota-forklifts.nl  
info@nl.toyota-industries.eu



## TOYOTA

### MATERIAL HANDLING

Toyota Material Handling (TMH) helps businesses of all sizes across Europe meet today's materials handling challenges with a full range of (automated) counterbalanced forklift trucks, warehouse equipment, automated warehouse solutions services and added value solutions, including service contracts, short term rental, used forklift trucks and fleetmanagement service.

Toyota Material Handling is active in more than 30 countries across Europe and has a headquarter based in Sweden and a European office in Belgium and production centres in Ancenis (France), Bologna (Italy) and Mjölby (Sweden).

Since the acquisition of Vanderlande, Bastian Solutions and viastore, it's Toyota Material Handling's ambition of becoming the first-choice

partner in material handling. We provide business as a total solution provider for projects of all sizes. We actively search for cutting-edge technologies in material handling equipment and proven operational strategies. Our team of experts harnesses the capabilities of scalable material handling systems, innovative software, and customized automation engineering to deliver comprehensive, tailor-made solutions.

Our customers are our number-one priority. By staying in close contact with you we can understand your needs and provide the solution, technology, energy, service and financial flexibility that fits your operation. We can do this by working according to TPS and TSC (Toyota Service Concept), and by continuously improving.

### Tradinco Instruments

David Remans  
Radonstraat 250  
2718 TB Zoetermeer  
The Netherlands

+31 (0)79 203 31 33  
www.tradinco.com  
sales@tradinco.com



Tradinco instruments, is a supplier for sensors, calibration, equipment, services and software. We have an excellent track record since 1963 and have strong links with the process industry and equipment manufacturers. With our knowledge and hands-on experience, we provide expert advice and if necessary we can design and supply custom instrumentation to match requirements in your application. Customizations can range from small modifications on existing equipment and sensors to completely new developed instruments and software. Our calibration test benches and AutoCal+ calibration software are used around the world. With our ISO17025 accredited calibration lab, we offer facilities and knowledge to do research or qualification tests.

Specifically for hydrogen applications, we offer dedicated sensors and can calculate expected service life of pressure transmitters based on the process conditions and advice on the best option for your application. Our sensors are already used for many years in hydrogen installations for the automotive and semiconductor industry. Next to this we offer customized test, measurement and calibration solutions. For more information, please visit our website or contact us via email or phone.



### TSG Group

Paul Simons  
Furkapas 8  
5624 MD Eindhoven  
The Netherlands

+31 (0)40 254 82 22  
www.tsggroup.nl  
info@tsggroup.nl



TSG Group is an engineering company headquartered in Brainport region Eindhoven - The Netherlands with a subsidiary at green chemistry and materials campus Brightlands Chemelot in Geleen – The Netherlands.

We develop and realize smart machines and products. By incorporating 3 important pillars Digitalization, Sustainability and Servitization, we can create future proof solutions with resilience. Preferably we would combine these for our B2B customers.

From a perspective of Digitalization we've build [www.waterstofnet.eu](http://www.waterstofnet.eu) and from a Sustainability point of view we are involved in Green Chemistry for conversion of residual gasses into other gasses including hydrogen on Chemelot Site. Within the energy transition we have developed a

new system precision component for a Dutch startup company in next generation heating-cooling equipment, followed by developing an assembly technique including tooling and also a special machine that is able to create a critical thermal bounded assembly for gas.

In our engineering we make use of tools like FEM and CFD to develop, simulate and optimize certain technical challenges. Along the development we will play an active role in development of sustainable business models taking the R-strategy into account from Rethink and Reduce to Repair, Remanufacturing and Recycling. Also the CO<sub>2</sub>-footprint and savings or improvements are a key driver to us to enable and accelerate developments in key societal challenges like the energy and materials transition.

### TSG Netherlands B.V.

Robbert Schirmer  
Laan van Londen 120  
3317 DA Dordrecht  
The Netherlands

+31 (0)88 147 15 00  
www.tsg-solutions.nl  
robbert.schirmer@tsgnortheurope.com



TSG Solutions is a global solutions provider. TSG Solutions has a large sales and service network across Europe and Africa. Thousands of TSG engineers and technicians across 30 countries serve our customers promptly and efficiently: Wherever the client is located TSG is around the corner. TSG provides a wide array of solutions combining equipment sales, services and projects to the energy distribution networks both retail and non-retail (industry) aimed at fuelling mobility systems through its six business segments. The business Segment TSG Gas is focusing on solutions for alternative fuels based on gasses CNG, LNG, LPG and Hydrogen. Regarding the hydrogen market, TSG Gas is a system integrator

of storage, mobility, marine and industry applications. We can provide several products from electrolysers, hydrogen fuel stations for mobility and marine sector until hydrogen storage systems in an EPC project approach. Storage systems with type 4 CPV up to 500 bar(G) with H<sub>2</sub> capacity of 560 kg complete installed on 20 FT trailer or ISO container. TSG Gas has a high-level service degree and can provide 24/7 services to their customer due to the automated field services system. Currently we are working on several projects mainly focused on hydrogen mobility systems and storage systems. If you have any questions or requests do not hesitate to contact TSG Gas.

## TU Delft

Peter Lucas  
Van der Burghweg 1  
2628 CS Delft  
The Netherlands

+31 (0)6 4249 8373  
www.tudelft.nl  
p.lucas@tudelft.nl

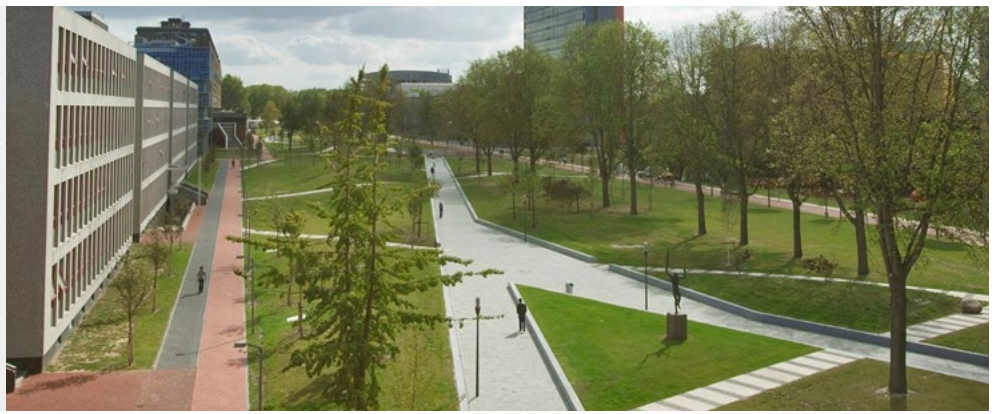

The TU Delft is the largest Dutch technical university and is highly ranked for engineering and technology worldwide. It contributes to solving global challenges by educating new generations of socially responsible engineers and expanding the frontiers of the engineering sciences. The research and field labs aims at delivering technology-driven, innovative solutions to societal problems through collaborations with leading national and international partners.

The TU Delft is active over the whole hydrogen (value) chain, from production to transportation, storage and distribution, to consumption in for example shipping, aviation, green steel and for seasonal balancing. However, also the whole energy system is considered and how hydrogen (carriers) can be used for large scale transport and storage.

The TU Delft Hydrogen Platform, part of Delft Energy, is the gateway for hydrogen research and innovation at the TU Delft. At TU Delft, roughly 250 researchers are, to some extent, involved in hydrogen research. Through collaboration with the other energy institutes like the e-Refinery, PowerWeb and Wind, multi-disciplinary research questions on for example offshore hydrogen and energy hubs can be tackled.)

## TwynstraGudde

Guus van Leerdam  
Oliemolenhof 14a  
3812 PB Amersfoort  
The Netherlands

+31 (0)33 467 7777  
www.twynstragudde.nl  
info@tg.nl



TwynstraGudde is an independent consultancy firm, serving public and private sectors. Our experience in the hydrogen sector covers the entire value chain, from production and global imports to the off-take by end users.

Our approach is scalable and applies to local projects (such as local eco-systems covering 400 houses), regional cases (such as transition roadmaps for industrial clusters), up to international context (such as development of cross-border hydrogen backbones, global import streams and securing strategic security of supply). Our mission is 'make the transition happen', by addressing and ranking the right value opportunities, business drivers, interests, and risks. Moreover, we are experts in bridging differences of interests or opinion between

partners and stakeholders, and ways to overcome hurdles (e.g. regulatory or financial).

Using our Cordence Worldwide network and working closely with our international partners, we offer global perspectives and track record to our customers. We believe managing transitions is not merely a technological challenge and that societal, economic and governance aspects are equally important. We execute projects in local, regional, national and international context: from local domestic communities to development of global supply streams.



**Van Campen Ecotechniek B.V.**

Marcel van Campen  
Keerkade 2  
3831 SN Leusden  
The Netherlands

+31 (0)6 22 46 05 75  
www.vcebv.nl  
mvancampen@vcebv.nl



Van Campen Ecotechniek, dealer for GreenMachines streetsweepers in the Netherlands, can deliver the GM500H<sub>2</sub> 'Hydrogen' as OEM worldwide.

The streetsweeper is very useful for city cleaning and silent while working, less dust, less heat, less weight, small and compact and with more range, it is a logical application.

If you lack the infrastructure, you can choose the cartridge system with H<sub>2</sub>-PODS and simply replace the empty ones when needed. Or you choose for the fixed hydrogen tank system when your city has an H<sub>2</sub> fuelling infrastructure in place.

It's that simple.

**VARO Energy Netherlands B.V.**

World Port Center, Wilhelminakade 919  
3072 AP Rotterdam  
The Netherlands

+31 (0)88 1007000  
www.varoenergy.com  
info@varoenergy.com

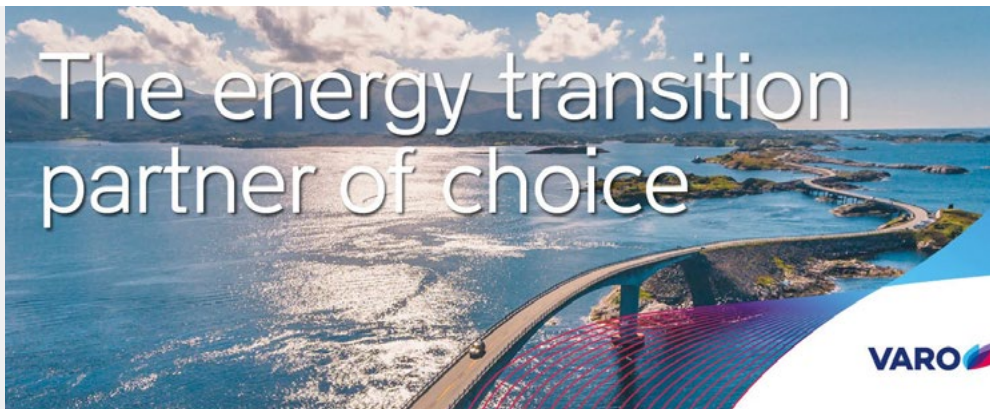

VARO Energy ("VARO") is the partner of choice for customers in the energy transition by providing the sustainable and reliable energy solutions that they need to decarbonise. Engine 1 includes manufacturing, storage, distribution, marketing, and trading of conventional energies. Engine 2 activities are focused on sustainable energies and include biofuels, biogas, green hydrogen, e-mobility, and nature-based carbon removals. VARO plans to invest around \$3.5 billion over the 2022-26 period, with two-third committed to sustainable energies. The company has a net zero target for scope 1, 2 and 3 by 2040. VARO is a Swiss-based private company.



**VDL Energy Systems B.V.**

Jim Arends  
Darwin 10  
7609 RL Almelo  
The Netherlands

+31 (0)74 240 20 00  
www.vdlenergysystems.com  
j.arends@vdlenergysystems.com



VDL Groep develops and produces a wide variety of industrial products, from parts to advanced finished products. Our activities can be summarised in the 'five worlds of VDL': Science Technology & Health, Mobility, Energy & Sustainability, Infratech and Foodtech. Each of these 'worlds' has its own characteristics and challenges, with one common denominator: a unique combination of thinking and doing. This sets us apart. As a family business founded in 1953, we cherish the values of workmanship, deliberateness and cooperation. Our employees are our organisation's greatest asset – they enable us to make the difference. By working together closely and combining workmanship with innovation, we inspire to make change happen. We are aware that the decisions we make today will affect the world of tomorrow. Together with our personnel and partners, we can make a difference today for a better world tomorrow.

VDL Groep has over 16,000 employees and is active in 19 countries. The group encompasses more than 100 closely cooperating operating companies, each with its own specialism. In 2022, VDL Groep achieved a combined annual turnover of €5,752 billion.

VDL Energy Systems is part of the VDL Groep, and a OEM in energy storage & conversion systems. Commercial available products are smart energy storage systems and energy management software. The prototype developments are hydrogen fuel cell generators and alkaline electrolysers.

**Veco B.V.**

Hans Berenschot  
Karel van Gelreweg 22  
6961 LB Eerbeek  
The Netherlands

+31 (0)6 10 96 95 47  
www.vecoprecision.com  
hans.berenschot@vecoprecision.com

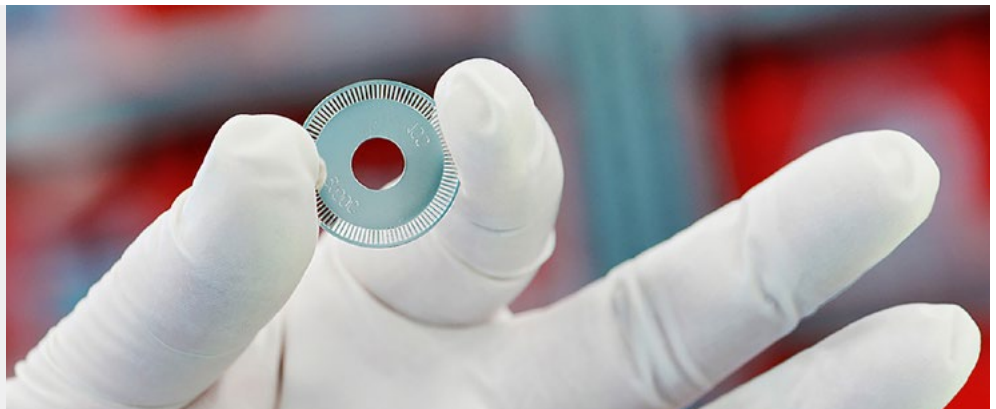

Veco is a world-leading manufacturer of micro-precision metal parts. It serves the world's most innovative, hi-tech companies from industries that demand high quality and precision. To meet customers' specifications and demands, Veco has developed high standards of performance in Electroforming. This technology allows a powerful combination of precision and economical production; for high volumes and prototypes, standard and custom-made products.

The main difference and advantage of Veco's electrodes is the enlarged surface area that can be achieved. Up to 14 times enlargement has been achieved when this Ni-E<sup>3</sup> process is used. In addition, several coatings can be applied that can further result in a surface enlargement of up to 20.000 times resulting in yields that are unprecedented in today's world. The process is sustainable due to zero waste, making it a very cost-effective and future-proof technology in producing Electrodes.

Veco's Ni-E<sup>3</sup> electrode solutions with surface enlargement up to 20,000 times. With the worldwide ongoing energy transition from fossil into green energy, electrodes are gaining more and more interest. Veco's electrodes solution with its unique properties can be used for Electrolysis, Fuel-cells, and Desalination.

**Vecom Group B.V.**

Sandra Vintges  
Mozartlaan 3  
3144 NA Maassluis  
The Netherlands

+31 (0)6 82 24 68 09  
www.vecom-group.com  
s.vintges@vecom.nl



Vecom is specialist in chemical technical cleaning on-site (worldwide) with over 65 years' experience. We can also carry out metal surface treatments in our metal laundries, located in The Netherlands, Belgium and the United Kingdom.

Vecom focuses on customer and process-specific solutions for complex contaminations and strives to be the best quality service provider in metal surface treatment. Knowledge and experience is combined with flexibility and operational perfection. When it comes to metal surface treatment, Vecom has the knowledge, expertise and equipment to deal with chemicals, metal and waste streams in a responsible way. Safety for people, the environment and your assets are key.

What can Vecom do for the H<sub>2</sub> network? When changing from natural gas to H<sub>2</sub> gas, the existing piping may need to be cleaned depending on fouling. Vecom has the knowhow and experience to chemically clean and/or decontaminate piping systems with a proven method of removal of hydro carbon and sulphur contaminations. Optionally also rust and other inorganic contaminations can be removed. If ultraclean specifications apply, oxygen cleaning and DNV approved methods will be used.

Furthermore, prefab parts for H<sub>2</sub> handling equipment can be pickled and passivated in our metal laundries. If required, the oxygen cleaning method can be applied as well. Please contact our specialists for suitable solutions.  
www.vecom-group.com

**VEGA level and pressure**

Joris van der Goes  
Arnhemseweg 213-2  
3817 CG Amersfoort  
The Netherlands

033 450 2502  
https://www.vega.com/nl-nl  
j.vandergoes@vega.com



VEGA produces instruments for level- and pressure measurements. VEGA employs over 2,200 people worldwide, 1,000 of whom work at its headquarters at Schiltach in the Black Forest. This is where, for more than 60 years now, solutions to demanding measuring tasks are being conceived and turned into reality. We have been supplying instruments to almost any industry imaginable, and now, also for the hydrogen industry.

Production processes are becoming increasingly complex. The measurement technology that is used to control and monitor processes should therefore be all the more comprehensible. VEGA has set itself the goal of developing innovative measurement technology that is easy to install and operate that provides maximum security and reliability.

VEGA is active in more than 80 countries with its globe-spanning network of subsidiaries. The company and its products have all the necessary certificates and approvals for world-wide application. This applies to the technical safety as well as to the quality of all products and services.

VEGA offers a wide range of instruments that are compatible with Hydrogen applications. Each with their own specific attributes to remain extremely accurate in harsh conditions. Moreover, due to our experience with our instruments that are already being applied within electrolyser, stacks and storage applications we are equipped and dedicated to help you make your project or product a success.



## Volth2

Bas Lavalaye,  
Groot Arsenaal, Rijtuigweg 44  
4611 EL Bergen op Zoom  
The Netherlands

+31 (0)85 081 77 20  
www.volth2.com  
info@volth2.com



Volth2 is committed to developing and operating green hydrogen plants in Europe. The company focuses exclusively on the large-scale production of green hydrogen. This hydrogen is intended for use by local industry and the transport sector.

The first two production facilities are currently being developed in Vlissingen and Terneuzen (the Netherlands). These plants are already licensed and are expected to be operational in 2026. Scalability has been taken into account in the design of both installations: in the initial phase, each installation will produce nearly 2 million kg (1,890 tonnes) of green hydrogen per year. In time, production will be expanded to grow along with the market for green hydrogen.

Since the spring of 2022, Volth2 has been developing a third green hydrogen plant in Delfzijl

(within Groningen Seaports). At the start-up, which is planned for the end of 2026, Volth2 anticipates a production capacity of approximately 50 MW (3,800 tonnes). This plant has also been licensed. At the beginning of 2023, Volth2 announced the development of a German hydrogen plant in Wilhelmshaven, Germany's primary energy hub. Later that year, steps were taken for a second and third German site in the industrial-rich Ruhr region, specifically in Essen-Frillendorf and Gelsenkirchen.

With the six current locations in the Netherlands and Germany, Volth2 has a portfolio with a potential production capacity of over 500 MW.

Volth2 is a collaboration between Volt Energy (the company of founder André Jurres), Virya Energy and DIF Capital Partners.

## VONK

Bart de Vries  
Dr. Klinkertweg 22b  
8025 BS Zwolle  
The Netherlands

+31 (0)85 303 20 40  
www.iivonk.com  
info@iivonk.com



VONK (fka Ampulz) is a solution provider for Power Conversion, Electrical & Instrumentation and Control & Automation Challenges. Inspired by technological innovations we contribute to a more sustainable society. We are an internationally recognized specialist when it comes to Power Conversion & Power Electronics. With our expert knowledge and extended experience as our foundation, we strive at all times to rise to the challenges of tomorrow. Current developments in the field of energy transition play an important role in this.

The incorporation of large-scale renewable energy sources requires power conversion solutions which can be used on a Megawatt level. The power converter determines the behaviour to the electricity grid, the extent of reactive currents and other power quality issues.

Cooperation with VONK will result in a power supply that exactly fits the electrolyser, with better integration characteristics and the lowest possible cost per kW. We aim for a collaborative approach and use standard building blocks to ensure rapid development for power supplies ranging from 1 to 250+ Megawatt. VONK has developed its own innovative electronics control platform to support our solution. The control platform is the heart of the power converter and is capable of forcing the maximum power point of the electrolyser. With its dedicated communication links it can align energy from fluctuating sources with the electrolyser capacity, to optimize the use of available renewable energy.



### Royal Vopak

Hans de Willigen  
Westerlaan 10  
3016 CK Rotterdam  
The Netherlands

+31 (0)6 13 43 18 40  
www.vopak.com  
hans.de.willigen@vopak.com



Royal Vopak is the world's leading independent tank storage company. We store vital products with care. With over 400 years of history and a focus on sustainability, we ensure safe, clean and efficient storage and handling of bulk liquid products and gases for our customers. By doing so, we enable the delivery of products that are vital to our economy and daily lives, ranging from chemicals, oils, gases and LNG to biofuels and vegoils. We are determined to develop key infrastructure solutions for the world's changing energy and feedstock systems, while also investing in digitalization and innovation. Vopak is listed on the Euronext Amsterdam and headquartered in Rotterdam, the Netherlands.

Vopak is exploring how to set up new renewable hydrogen supply chains between production and

demand centres in Europe and beyond. Next to pipelines, other infrastructure will be needed to enable safe, substantial, flexible and cost-effective international transportation, storage and distribution of hydrogen. Vopak aims to provide solutions by creating open access terminal infrastructure at both export and import locations. Together with partners in various countries, Vopak aims to develop storage and transportation, using three technologies: Liquid Organic Hydrogen Carriers, Green Ammonia, and Liquefied Hydrogen.

Vopak is also a partner in the H-vision project that aims to substantially reduce emissions of the Rotterdam industry through low-carbon hydrogen. Please visit [www.vopak.com](http://www.vopak.com).

### Voyex B.V.

Peter Coppens  
Molengraaffsingel 10  
2629JD Delft  
The Netherlands

+31 (0)6 4079 7958  
www.voyex.nl  
peter.coppens@voyex.nl



Voyex develops Liquid Organic Hydrogen Carrier (LOHC) technology. With this technology, we bond hydrogen to a safe and easy to use liquid that is similar to diesel in terms of handling and storage. Inside heavy-duty mobility applications, hydrogen is released from the liquid and made available to power engines. The LOHC is circular and can be used hundreds of times to bond and release hydrogen.

Voyex LOHC is characterized by a 'safer-than-diesel' hazard level and efficient conversions through smart heat integration with hydrogen combustion engines. The combination of high hydrogen storage content (+/- 60 kg H<sub>2</sub>/m<sup>3</sup>) and usage at atmospheric pressures and room temperatures overcomes major storage and distribution (S&D) challenges associated with the cost and efficiency of conventional hydrogen S&D

methods.

With this technology, we aim to provide a substitute for diesel in applications used in building & construction, marine and trucks. Next to using the LOHC as a fuel, it is also perfectly suitable for medium-to-long transport of hydrogen.

Voyex' 3 core activities are synthesis of the LOHC substance from sustainable raw materials, developing technology to bond the hydrogen ('hydrogenation') and releasing the hydrogen ('de-hydrogenation'). We develop our technology in-house in the Netherlands in our labs and offices in Delft. Our aim is to deliver a pilot-scale value chain in 2025 (incl. 10 operational systems in the field) and achieve commercial roll out of all technology components in 2026.

**VTTI**

Rob Penne  
Fascinatio Boulevard 208  
3065 WB Rotterdam  
The Netherlands

www.vtti.com  
newenergies@vtti.com



: VTTI is one of the world's leading storage providers for energy and other essential products like chemicals, with its headquarters in Rotterdam, The Netherlands. Located at major shipping crossroads and supply gateways, VTTI provides over 10 million cubic metres of storage capacity across five continents. VTTI focusses on developing and implementing sustainable solutions, fueling the transition to the energy needs of tomorrow and building the emerging renewable value chain. We focus on transitional and new energy, among which green gas, hydrogen, CO2 capture and other renewable products.

VTTI aims to develop hydrogen import facilities to convert imported green ammonia to green hydrogen to help decarbonize industrial areas as

well as hard to abate industrial clusters in north-western Europe through the European hydrogen backbone system.

In addition, VTTI is partnering in green hydrogen conversion projects across the globe, ranging from green ammonia export terminals to, liquid organic hydrogen carriers and establishing green corridors for the marine sector.

VTTI has a long history of providing active solutions in the key energy locations of the world, and we have a proven track record of growth. We have created brand-new, world-class greenfield terminals in locations like Rotterdam and Malaysia while also acquiring, enhancing and revitalising established terminals like in Antwerp.

**Water Alliance**

H.W. Molenkamp  
Agora 4  
8934 CJ Leeuwarden  
The Netherlands

+31 (0)58 284 90 44  
www.wateralliance.nl  
info@wateralliance.nl



Water Alliance is a unique partnership of public and private companies, government agencies and knowledge institutes involved in the Dutch water technology. We focus on innovative and sustainable water technology that can be used worldwide and support small and medium sized enterprises in the water technology industry in terms of (international) matchmaking, networking and business development. Water Alliance is based at WaterCampus Leeuwarden, the Netherlands. WaterCampus Leeuwarden is the physical core of the Dutch water technology sector and has the ambition to play a sector uniting role for the rest of Europe as well. The WaterCampus is an innovation ecosystem, which brings together a complete chain of innovation for water technology, from first ideas to research & development, specialised laboratories, a water application centre and various demo sites

to launching customers and ultimately tangible business. We help companies to find the best way through the innovation chain to cover their needs and speed up their developments. WaterCampus stimulates cooperation between (inter)national businesses, knowledge institutes and governments within the water technology sector, in order to create synergy for world class innovation, education and entrepreneurship. This strengthens the global position of the European water technology sector. Additionally, WaterCampus offers a unique research infrastructure, and is a meeting point for scientists and companies from all over Europe. The international cooperation organised and stimulated by WaterCampus Leeuwarden leads to knowledge, talent and entrepreneurship that contribute to solutions for global water problems.



**WE | doubleyouenergy B.V.**

René Wit  
Terborgsteeg 4  
9751 BN Haren  
The Netherlands

+31 (0)6 2291 6996  
www.we-doubleyouenergy.com  
doubleyouenergy@gmail.com

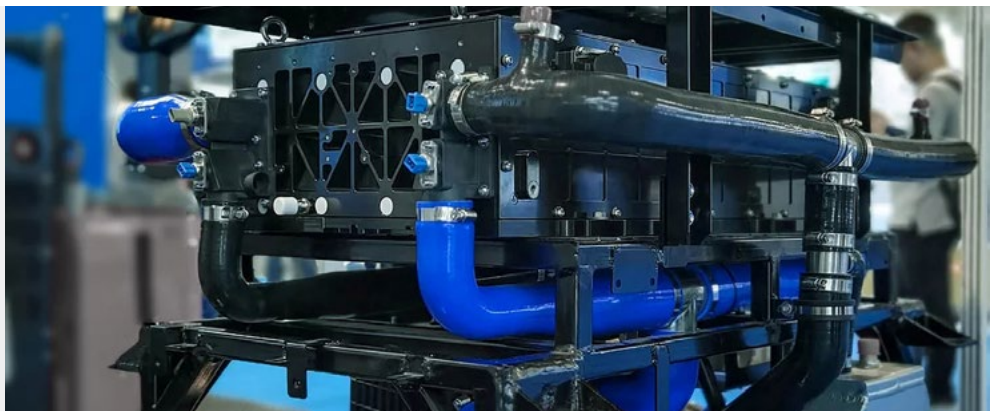

WE – doubleyouenergy® started in the hydrogen world in 2018 and is H2planet Netherlands and Horizon Fuel cell Netherlands, WE – doubleyouenergy® sells Hydrogen electrolysers, storage systems high pressure up to 1000kg / 450bar and metals hydride systems, fuel-cells and hydrogen, methanol and bio-gas electricity generator sets from 20 Watt to 2 MW.

For the Netherlands, WE - doubleyouenergy® is the exclusive re-seller of h2planet products, distributor of Horizon fuel-cells and is agent of UMOE advanced composites, with this participating towards a more sustainable and cleaner world!

WE - doubleyouenergy®, not only sells but also designs and builds hydrogen systems together with the client and come to the best suitable solutions for your hydrogen requirement, WE - doubleyouenergy®

is a start-up, small but can think big and has a portfolio with some of the biggest suppliers like Horizon, UMOE and H2planet, they have everything you need!

WE - doubleyouenergy®, has done many projects, i.e. starting with hydrogen cargo bikes for Maximator Hydrogen compressor company as an example what can be done with hydrogen and the municipality of Groningen as a prototype trial. Further the off grid Tiny Solar Hydrogen House Hoogeveen for the municipality of Hoogeveen. And the Solar Hydrogen generator sets for Royal Oosterhof Holman and Volta Energy, also we supplied i.e. the 40kW fuel cell for the Technical University of Delft which was installed in a open sea race boat which became world champion during the Monaco open sea race boat challenge.

**Wigersma & Sikkema B.V.**

Brent Teijssen  
Leigraafseweg 4  
6983 BP Doesburg  
The Netherlands

+31 (0)313 47 19 98  
www.ws-gas.com  
info@ws-gas.com

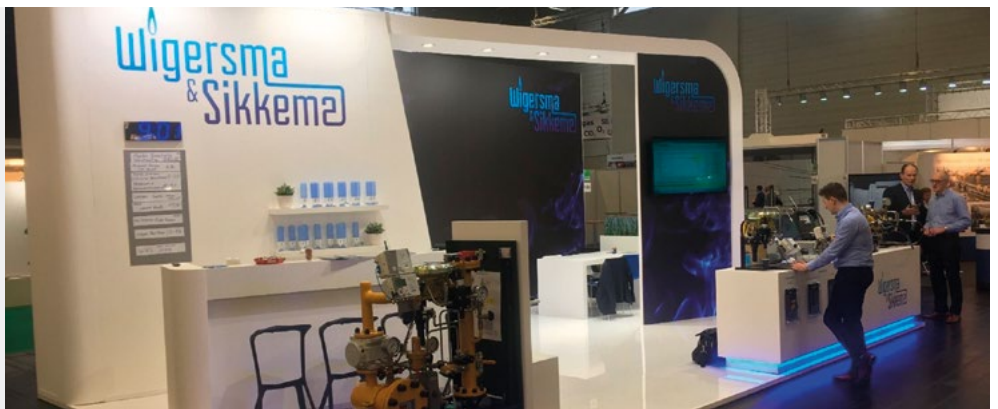

Wigersma & Sikkema B.V., founded in 1921, develops, produces and delivers measurement and control equipment for gas distribution. Products include Electronic Volume Conversion Devices (UNIGAS 300), remote reading systems such as dataloggers and modems (UNICOM 300), gas pressure regulators (RS350S) and inspection systems for gas pressure regulating stations (PLEXOR). With these high-tech products, we are the market leader in the Netherlands and are increasingly gaining a foothold internationally. With years of knowledge and experience and our own R&D and production, we can optimally respond to changes in the market, such as hydrogen and green gas. Wigersma & Sikkema is known for quality products, fast delivery and excellent technical service.

KIWA was commissioned by Netbeheer Nederland to investigate whether existing gas pressure regulation stations for natural gas are suitable for the use with 100% hydrogen. The gas pressure regulation station which was tested had a W&S RS350S DN50 regulator built in. The station was equipped with BMA and BDA system couplings to connect the PLEXOR inspection system. A UNIGAS 300 electronic volume converter was used to measure and record pressure, temperature and flow. For several tests, the PLEXOR inspection system was used. The conclusion is that the station can be operated with 100% hydrogen without modification.



**Witteveen+Bos**

Raphaël van der Velde  
Leeuwenbrug 8  
7411 TJ Deventer  
The Netherlands

+31 (0)6 13 53 24 28  
www.witteveenbos.com  
raphael.van.der.velde@witteveenbos.com

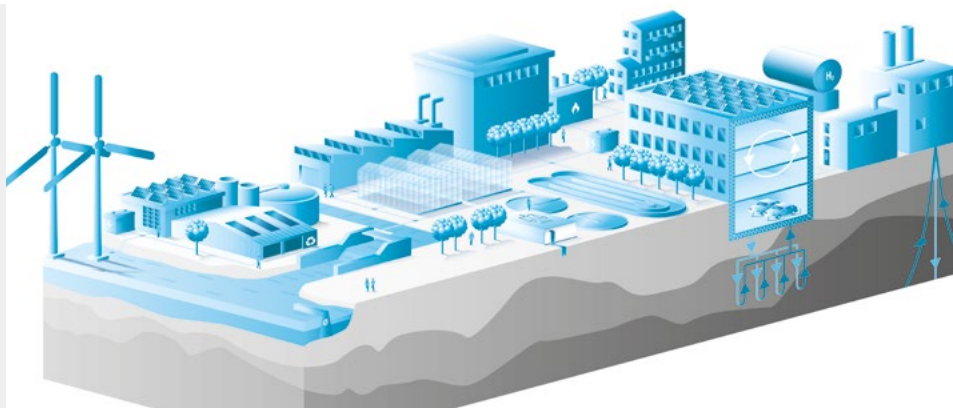

Witteveen+Bos is an international consultancy and engineering firm that offers solutions to complex engineering and societal issues in the fields of energy, water, infrastructure, the environment and construction. We strive to operate at a high-quality, international level of engineering. Our staff of some 1,400 employees work in multidisciplinary project teams on innovative projects all over the world. The energy transition, climate adaptation, flooding problems, healthy cities, the circular economy and largescale replacement of infrastructure are just some of the major challenges which we can help to overcome.

Specifically for hydrogen, Witteveen+Bos offers services on the following topics: system integration, risk assessments (QRA), safety (HAZID/HAZOP), permits, technoeconomic feasibility, roadmaps (vision and strategy), innovation, engineering, stakeholder management, grant support, project management and consortium formation.

**WSP**

Tom Klaassen  
Tramsingel 2  
4814 AB Breda  
The Netherlands

+31 (0)88 910 20 00  
www.wsp.com  
nl.info@wsp.com



WSP is a consulting and engineering firm operating worldwide. In the Netherlands, we have 400 employees working at 10 local offices, offering technical expertise and strategic advice to clients in the sectors Buildings, Infrastructure, Energy, Water and Environment.

Having spent decades working within the gas industry, coupled with our Carbon Capture Utilisation and Storage (CCUS) experience and experience with re-purposing natural gas pipelines to hydrogen pipelines, or engineering new ones, we believe we are strongly positioned to deploy market-leading, clean hydrogen projects for our clients. We have harnessed a multi-disciplinary, global approach when tackling the hydrogen challenge. We understand the complete hydrogen value chain and offer sector-

wide expertise and consultancy; with the ability to harness knowledge from a broad range of disciplines and services, as well as internationally. This enables us to advise throughout the design lives of our client projects for hydrogen production, storage, transmission, distribution, and utilisation across multiple sectors.

Hydrogen aligns with our 'Future Ready' innovation programme, which supports our ambition to advise on solutions that are both ready for today and the years to come, giving our clients confidence that we will tailor our approach on a project by project basis to embed sustainability and resilience into our planning and designs.

## XINTC

Wilko van Kampen  
Loubergweg 22-24  
6961 EK Eerbeek  
The Netherlands

+31 (0)85 070 2548  
www.XINTC.global  
wka@XINTC.global



XINTC is shaping the future of hydrogen by developing, producing and marketing modular, scalable industrial alkaline electrolysers (AEL) in the power range from 150kW to 100+ MW at the desired purity and with a variable output pressure between 1 bar (14.5 Psi) and 13 bar (188.55 Psi). XINTC electrolyser systems can be used in a wide variety of applications at any location in the world, ranging from mobility to build environment and industry. They are very well suited for dynamic operation and direct connection to renewable energy sources (PV-field, wind turbines). Each system comprises a family of interconnecting gas modules, supported by all necessary supporting components and auxiliary

systems for operational performance and plant safety. Gas modules are equipped with embedded electronics and smart control software, allowing the electrolysis process to run smoothly at maximum efficiency. System design is based on product configuration rather than custom engineered solutions. In order to execute capacity expansion rapidly, XINTC uses modular and standardized components. Time-consuming EPC procedures therefore belong to the past. To satisfy future demand throughput, capacity is expandable in chunks of 150kW. Efficiency, low operating costs, ease of use, and high safety standards are key values of XINTC electrolyser systems.

## zepp.solutions

Mr Jonas Brendelberger  
Paardenmarkt 1  
2611 PA Delft  
The Netherlands

+31 (0)15 203 00 44  
www.zepp.solutions  
info@zepp.solutions



zepp.solutions develops hydrogen fuel cell systems for clean, mobile power generation. Our systems are based on a highly scalable and modular platform to allow the fast adaption to different use cases and applications. This technology enables the emission-free propulsion or operation of any application, vehicle or vessel without any drawbacks.

We also support concepts and projects with our consulting and engineering services.

Some of the current projects include the development of hydrogen fuel cell powered yard tractors with vehicle OEM Terberg Special Vehicles. These vehicles enable an emission free horizontal container transport in ports and distribution centres. The first prototype is in active operation.

Furthermore, we develop different size fuel cell system solutions for the maritime sector. Examples are the first hydrogen fuel cell powered Watertaxi in the Port of Rotterdam and a scalable, high power fuel cell module for auxiliary or main propulsive power in large vessels and shipping operations.

**Zeton B.V.**

Herman Bottenberg  
Marssteden 206  
7547 TD Enschede  
The Netherlands

+31 (0)53 428 41 00  
www.zeton.com  
info@zeton.nl

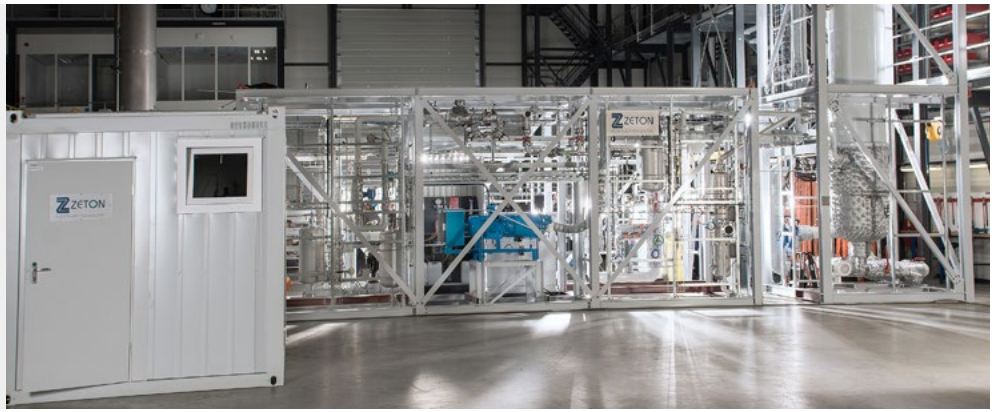

Are you looking for a partner, which provides the expertise in designing and building process systems to prove your scaled-up technology? As the world's leading Designer and Builder of innovative lab scale systems, pilot plants, demonstration plants and small modular production plants, Zeton helps its customers bring their processes from lab to market, faster, with less risk and lower cost. Our projects are realized in a vast range of industries, amongst which CO<sub>2</sub> utilisation, Pharma, Chemicals, Biobased fuels and chemicals, Petrochemicals, Oil&Gas, Food, Paper & Pulp. In many of these industries projects are realised which use hydrogen either as raw material, intermediate or product. Our full suite of pilot plant and engineering solutions allows us to deliver scale-specific

projects with design, procurement and fabrication executed in parallel – compressing the overall project schedule and maximizing cost-efficiency with our unique project methodology. Your intellectual property is protected as our engineers optimize the design and build of your project, allowing you to take your process technology to market sooner. With state-of-the-art, integrated design-build facilities in Enschede, The Netherlands, and Burlington, Ontario, Canada, Zeton has successfully completed over 800 projects in 35 countries across six continents. For more information, please visit our website [www.zeton.com](http://www.zeton.com)

ZETON, one partner from early phase concept to real built process plants.



This is a joint publication by:

**Netherlands Enterprise Agency (RVO)**

Graadt van Roggenweg 200  
P.O. Box 8242  
3531 AH Utrecht  
The Netherlands  
T +31 (0) 88 042 42 42  
E [redesk@rvo.nl](mailto:redesk@rvo.nl)  
W [www.rvo.nl](http://www.rvo.nl)

**FME**

P.O. Box 190  
2700 AD Zoetermeer  
The Netherlands  
T +31 (0)79 353 11 00  
E [internationaal@fme.nl](mailto:internationaal@fme.nl)  
W [www.fme.nl](http://www.fme.nl)

**TKI New Gas (Topsector Energy)**

Groen van Prinstererlaan 37  
3818 JN Amersfoort  
The Netherlands  
T +31 (0)6 45 25 15 71  
E [jorg@gigler.nl](mailto:jorg@gigler.nl)  
W [www.topsectorenergie.nl/en/tki-new-gas](http://www.topsectorenergie.nl/en/tki-new-gas)

Though great care has been taken in the preparation of this publication, the publishers cannot be held liable for damages of any kind arising from its use. Nothing in this publication may be reproduced or made public by means of print, photocopy, microfilm or any other method without the prior written permission of the publishers.

This publication was edited by David Koole, Kenneth Colijn, Jeroen van Gils, Gijs Mulder and Claire Hooft Graafland (RVO), Jelle Blekxtoon and Marleen Volders (FME). Thanks to Jörg Gigler, Han Feenstra, Hugo Brouwer, Dana van der Zee and Nick Bijlsma for their cooperation. Concept development, copywriting and design by Fortelle and NL Branding.

Would you like to present your company profile worldwide in the next edition of the NL branded guide 'Excelling in Hydrogen'? Please send your request to [hydrogen@fme.nl](mailto:hydrogen@fme.nl).

**Photo credits**

PosHYdon (cover, p. 15 bottom left), Gasunie (p. 4/5, p. 17 middle right, bottom left), TNO/Eric de Vries (p. 6, p. 12/13), Sake Elzinga (p. 8/9, p.19 middle right), Enercon (p. 19 middle right), Port of Rotterdam (p. 16/17), Hylife Innovations (p. 17 top right), Dow (p. 19 bottom right), Vattenfall (p. 22), Battolyser Systems (p. 23 top), DNV GL (p. 23 middle left), HYGRO (p. 22 right), Luca Locatelli (p. 28/29)

Version: May 2024



Netherlands Enterprise Agency





**NL**

**Netherlands**